

Customer Expectations Guide

BF-450e/435e System - Kyocera

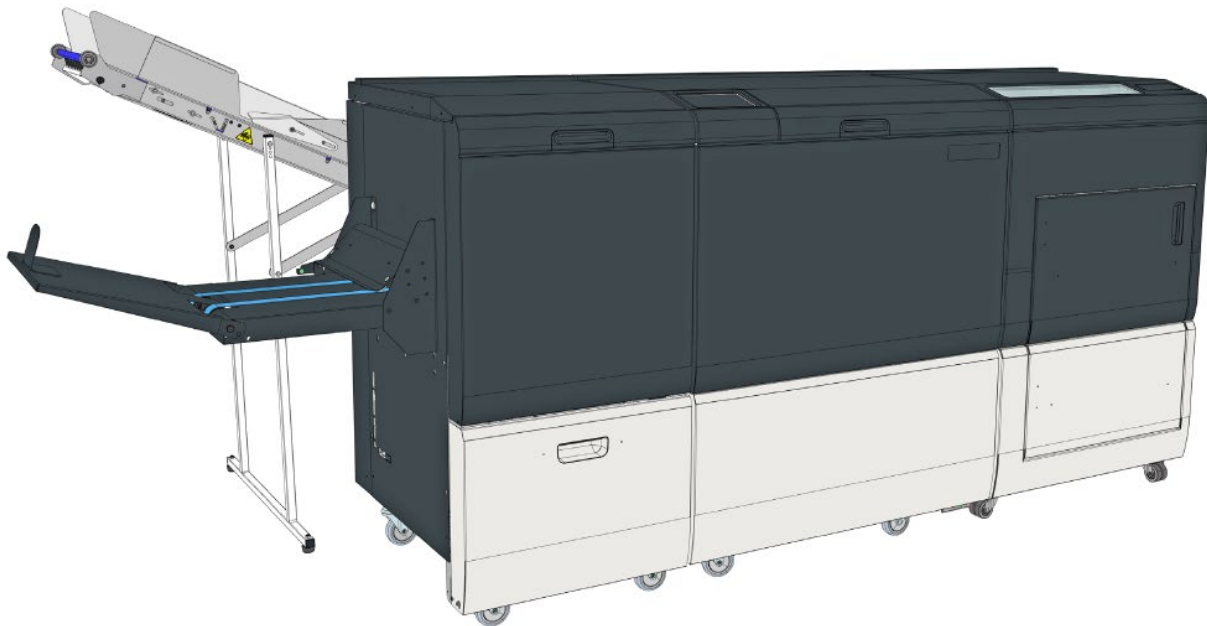

This CEG is intended as an aid in the discussions with customers prior to signing order and prior to planning the installation to set the correct expectations

Introduction

The Plockmatic BF-450e or BF-435e Production Booklet Maker System consists of:

- BF-435e/450e Booklet Maker, also referred to as the Booklet Maker, BM or BF-435e/450e
- Finishing Module (optional), also referred to as the Finishing Module or FM-400e (mandatory in US)
- Rotate Crease Trim Module (optional), also referred to as the RCT or RCT 3.0 (only available in US)
- Trim Waste Conveyor (optional), also referred to as the TWC (only available in US)
- BST4000-1 Belt Stacker Module (optional), also referred to as the BST Module

Together they form a system that allows booklet making inline with sheets coming from the Printer.

The BF-450e upgrade kit raises the capacity of the BF-435e Booklet maker from 35 sheets to 50 sheets. The 50-sheet upgrade kit version requires an FM-400e Finishing Module.

The RCT Module can be programmed to crease the cover sheet and the centrefold to avoid paper fibre from breaking when the folded. The RCT can also trim the long sides (head and foot) of the booklet sheets to deliver booklets in the desired size. Together with the Face Trimmer in the Finishing Module, the RCT enables production of full bleed saddle stapled booklets. The optional RCT requires an FM-400e Finishing Module and is an option available only in the US.

About this Guide

This Expectations Guide is developed for the Kyocera Analyst and the Coordinating Customer Sales resource as a tool in the discussions with customer to clearly explain any mechanical limitations and general specifications of the configuration and outline specific pre-installation tasks that needs to be completed prior to installation.

Table of Contents

Introduction.....	2
About this Guide.....	2
Product Overview	4
Performance Specifications	4
General Specifications	4
Specifications, Finishing Module	5
Specifications, RCT 3.0.....	6
Booklet Set Size Guide	7
Saddle Stapling specifications.....	8
Corner and Edge Staple specifications.....	8
Install Planning	10
Device Configurations.....	10
System Dependencies and Prerequisites.....	11
Printing Systems	11
Upstream Kyocera Interface.....	12
Dimensions and weights.....	13
Footprint.....	13
Weight and Size	14
Electrical Requirements.....	16
North America	16
Europe	16
Environmental Requirements.....	17
Estimated Installation Time	17
Operating Supplies.....	17
Interchangeability.....	17
Limitations	18
RCT Limitations	20

Product Overview

Performance Specifications

General Specifications

Feature		Specifications	Remarks
Speed (Online usage)		Maintain engine speed while collating duplex printed sheets (actual depends on engine speed).	Actual speed in number of booklets (per min / hour) depends on number of sheets per booklet.
Standard Paper Sizes	Booklet making*	A5, JIS B4, A4SEF, A4LEF, SRA4SEF, SRA4LEF, A3, SRA3, 210x610, 225x610, 210x620, 225x620, 320x620, 210x660, 225x660, 6x9", 8.5x11"SEF, 8.5x11"LEF, 9x12"S, 9x12"LEF, 11x17", 12x18", 8.5x24", 9x24", 8.5x25", 9x25", 8.5x26", 9x25"	SEF= Short Edge Feed LEF= Long Edge Feed *Maximum and minimum paper sizes depend on printer. When attached to TASKalfa Pro 15000c, max paper length is limited to 470mm /18.5"
	Edge Stapling	A4SEF, A4LEF, 8.5x11SEF, 8.5x11LEF	SEF= Short Edge Feed LEF= Long Edge Feed
	Corner Stapling	A4LEF, 8.5x11LEF	SEF= Short Edge Feed LEF= Long Edge Feed
Custom Paper Size Booklet making	Paper Size (Minimum)	Width 145 mm* / 5.7" Length 210 mm / 8.27"	*Note: Minimum paper width after bleed trimming in RCT is 148mm or 5.83"
	Paper Size (Maximum)	Width 320 mm / 12.6" Length 470 mm / 18.5"	
Custom Paper Size Edge Stapling	Paper Size (Minimum)	Width 210 mm / 8.27" Length 210 mm / 8.27"	
	Paper Size (Maximum)	Width 297 mm / 11.6" Length 297 mm / 11.6"	
Custom Paper Size Corner Stapling	Paper Size (Minimum)	See standard paper sizes for corner stapling	
	Paper Size (Maximum)	See standard paper sizes for corner stapling	
Output size Booklets	Min. Size	145x99mm / 5.7x3.9"	With maximum face trim
	Max. Size	320x235mm / 12.6x9.25"	With no face trim.
Output Size Edge Stapling	Sizes	A4 or 8.5x11" Portrait orientation A4 or 8.5x11" Landscape orientation	Bleed or face trim not available in this mode
Output Size Corner Stapling	Sizes	A4 or 8.5x11" Portrait orientation	Bleed or face trim not available in this mode
Paper Weight Booklet making	Paper Weight (Minimum)	64gsm / 16 lb. Bond uncoated (60gsm*) 100gsm / 28 lb. Bond Coated	*60gsm/16lb Bond supported for some media. Testing and verification on specific customer paper required.
	Paper Weight (Maximum)	300gsm / 110 lb Cover (350gsm*)	*350gsm supported on some media.
Paper Weight Edge Stapling	Paper Weight (Minimum)	80gsm / 20 lb. Bond	Plain paper only
	Paper Weight (Maximum)	120gsm / 32 lb. Bond	Plain paper only
Paper Weight Corner Stapling	Paper Weight	80gsm / 20 lb. Bond	Plain paper only
Input / Output Sheets		1 – 50 Sheets (80gsm / 20 lb. Bond, equivalent), for BF-450e 1 – 35 Sheets (80gsm / 20 lb. Bond, equivalent), for BF-435e	Stapled and folded
Input / Output Sheets		1 – 2 Sheets	Non-stapled and folded.
Offline Use		Possible but not recommended	
Dimensions (L x D x H)		1635 x 685 x 1140mm / 64.4" x 27" x 44.9"	Incl. Output Stacker
Power Source		100-240 V; 50-60Hz; 4-2A; AC	+ - 10%
Power consumption (Standby)		100W	
Power consumption (Max)		400W	Includes FM-400e module, during production
Noise emission		65 dB	Complete system
Gross Weight		230 kg / 507 lbs	

Specifications, Finishing Module

Feature	Specifications	Remarks
Standard Paper Sizes	Same as BF-450e / BF-435e	Custom sizes are available
Default trim length	Depends on set thickness	Adjustable in 0.1 mm steps
Minimum trimming	2 mm / 0.2"	Adjustable in 0.1mm / 0.1" steps. For booklets made of sheets equal to or longer than 654mm/25.75", when face trimming, maximum finished booklet size is limited to 325mm/12.8".
Maximum trimming	231mm / 9.09"	Adjustable in 0.1 mm steps.
Paper Weight (Minimum)	Same as BM	
Paper Weight (Maximum)	Same as BM	
Input / Output Sheets	35 or 50	
Off-line Use	Not possible	
Power Source	From BM	
Gross Weight	168 kg / 370 lb.	Including packaging

Specifications, RCT 3.0

This option is only available in the US market.

Feature	Specifications	Remarks
Speed	Same as BF-450e/BF-435e	Trimming or creasing does not affect productivity
Standard Paper Sizes	A5, JIS B4, A4S, A4L, SRA4S, SRA4L, A3, SRA3, 210x620, 225x620, 320x620 6x9", 8.5x11"S, 8.5x11"L, 9x12"S, 9x12"L, 11x17", 12x18", 8.5x24", 9x24"	Custom sizes available. Smallest paper size RCT can cut down to is 148mm or 5.83". Maximum paper length if configuration includes RCT module is 620mm / 24"
Off-line Use	Not Possible	
Max side trim	30mm / 1.18"	Trimmed from top and bottom of each sheet. (60mm total = 30mm + 30mm)
Min trim	5mm / 0.20"	Trimmed from top and bottom of each sheet. Bypass possible
Power Source	100-240V 50-60Hz, 4-2A	+6% -10%,
Power consumption	300W, idle 400W, peak	Continuous Operations

Booklet Set Size Guide

The following tables are guidelines designed to give an indication on how many sheets a specific application can have for a given media weight. Exact number of sheets is depending on media type and image. Area coverage refers to the printed area on a sheet. For example, full area coverage indicates that the entire page is covered with ink. Note that for some “dense” or wavy media, sheet count may be reduced.

BF-450e

Paper weight				Paper Size				Paper Size Longer than 457mm/ 18"				Paper Size up to 250mm/9.8" in process direction				A4 or 8,5x11"	
Bond	Cover	Index	Gsm	A3 or 11x17"		A4 or 8,5x11"		Area Coverage		Area Coverage		Area Coverage		Finish type			
				Low	Full	Low	Full	Low	Full	Low	Full	Corner	Edge				
20	28	42	80	50	32	50	32	50	32	45	28	50	50	Corner	Edge		
24	33	50	90	45	32	44	32	45	32	39	28	N/A	28	N/A	28		
31	45	66	120	25	24	26	25	25	24	23	22	N/A	22	N/A	22		
36	50	75	140	20	17	22	20	19	17	19	18	N/A	N/A	N/A	N/A		
53	74	110	200	15	14	15	15	15	14	13	13	N/A	N/A	N/A	N/A		
58	80	120	220	13	12	14	12	13	12	12	10	N/A	N/A	N/A	N/A		
76	105	158	280	12	10	10	10	12	10	9	9	N/A	N/A	N/A	N/A		
82	114	170	300	9	9	9	9	9	9	8	8	N/A	N/A	N/A	N/A		

BF-435e

Paper weight				Paper Size				Paper Size Longer than 457mm/ 18"				Paper Size up to 250mm/9.8" in process direction				A4 or 8,5x11"	
Bond	Cover	Index	Gsm	A3 or 11x17"		A4 or 8,5x11"		Area Coverage		Area Coverage		Area Coverage		Finish type			
				Low	Full	Low	Full	Low	Full	Low	Full	Corner	Edge				
20	28	42	80	35	32	35	32	35	32	35	28	35	35	Corner	Edge		
24	33	50	90	35	32	35	32	35	32	35	28	N/A	28	N/A	28		
31	45	66	120	25	24	26	25	25	24	23	22	N/A	22	N/A	22		
36	50	75	140	20	17	22	20	19	17	19	18	N/A	N/A	N/A	N/A		
53	74	110	200	15	14	15	15	15	14	13	13	N/A	N/A	N/A	N/A		
58	80	120	220	13	12	14	12	13	12	12	10	N/A	N/A	N/A	N/A		
76	105	158	280	11	10	10	10	12	10	9	9	N/A	N/A	N/A	N/A		
82	114	170	300	9	9	9	9	9	9	8	8	N/A	N/A	N/A	N/A		

Set sizes in grey cells are outside of the recommended range of gsm for these paper sizes.

When producing booklets whose final width is 125mm or less, it is recommended to use sheets longer than 250mm in process direction and to trim the finished booklet down to the desired width. Should it be not possible to use sheets longer than 250mm in process direction, it is recommended to follow these guidelines:

- Minimum media weight: 110gsm, Maximum media weight: 180gsm
- Minimum number of sheets in set: 4, Maximum number of sheets in set: 30

Running a job outside of these guidelines may lead to an increased jam rate, uneven squareback or inaccurate face trimming on the finished booklets.

Saddle Stapling specifications

Metric example

The pictures below show the staples position on a A4 set of sheets. Pictures are not to scale.
Note! The staple center to center distance of 118mm is fixed for any sheet size and cannot be modified.

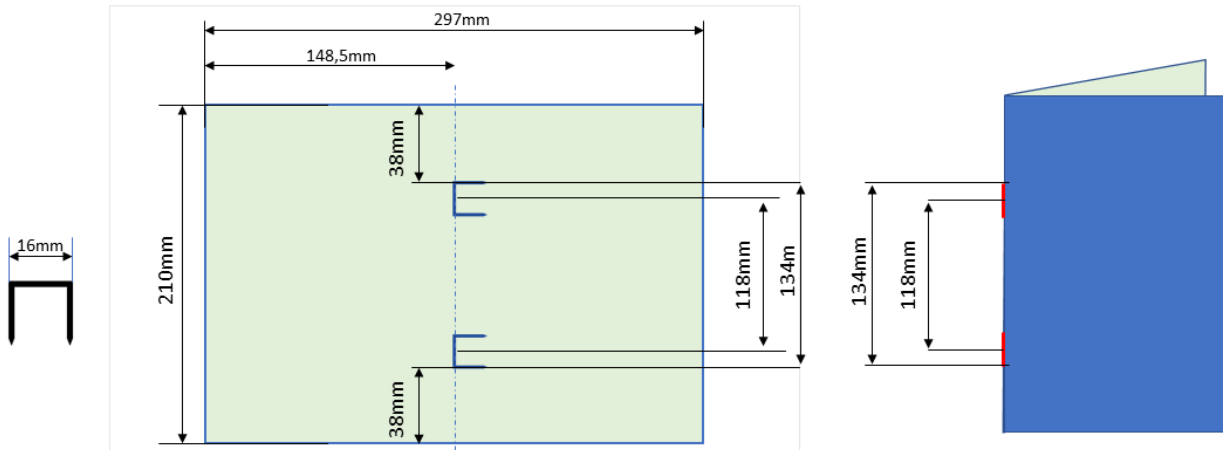

Imperial example

The pictures below show the staples position on a letter sized (8.5x11") set of sheets. Pictures are not to scale.
Note! The staple center to center distance of 4.6" is fixed for any sheet size and cannot be modified.

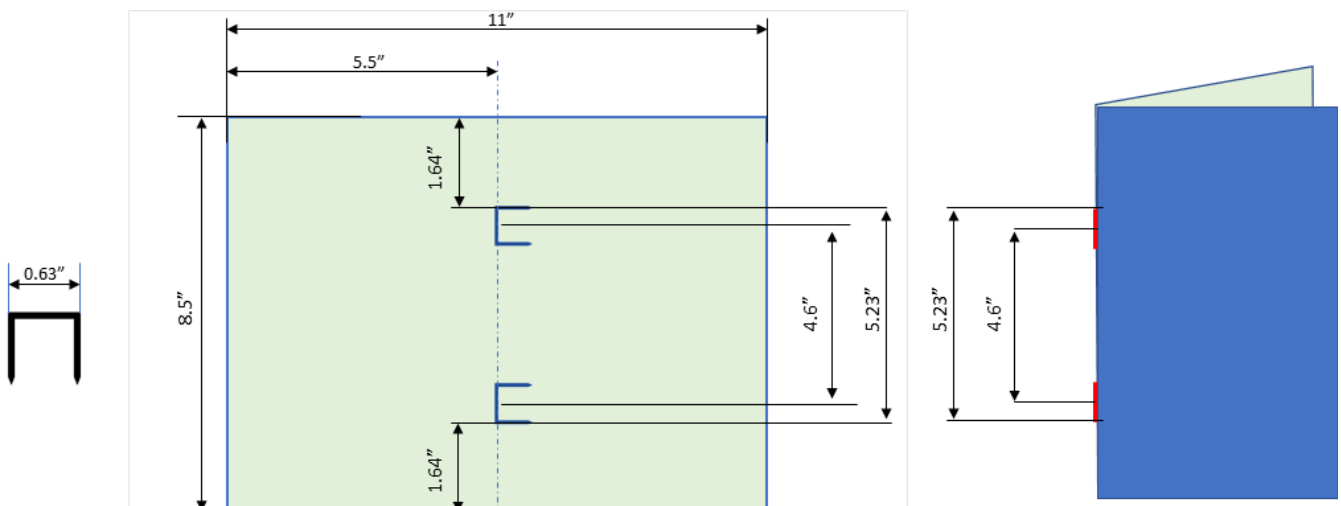

Corner and Edge Staple specifications

Specification of Corner Stapling mode for A4 LEF and Letter LEF sizes described below:

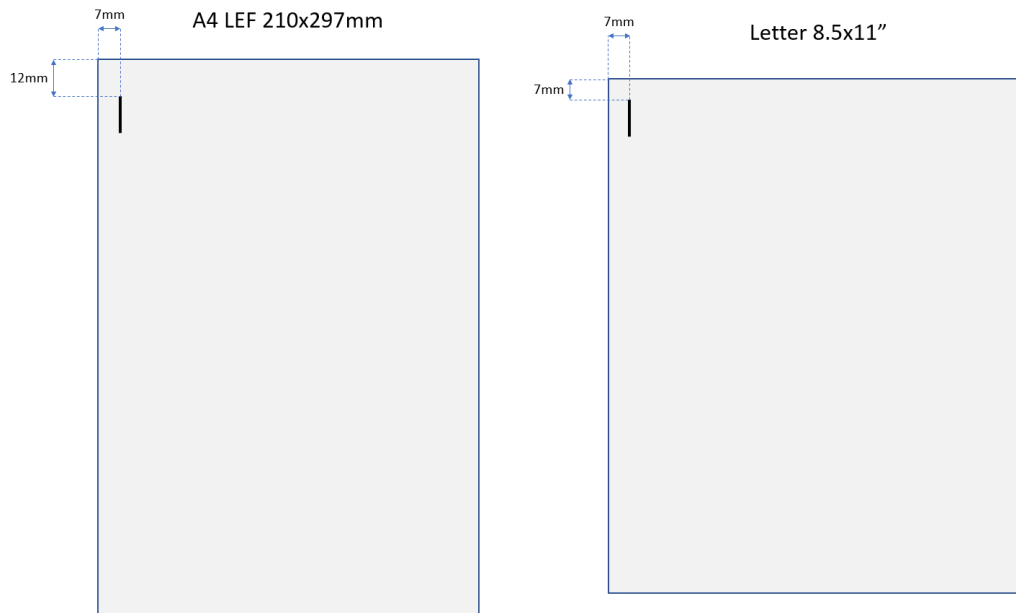

Note! The corner stapling position is fixed for any sheet size and cannot be modified.

Specification of Edge Stapling mode described below for all compatible paper sizes:

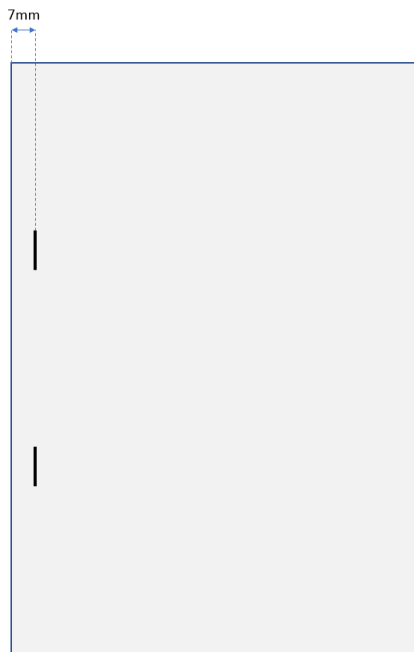

Note! The edge stapling position is fixed for any sheet size and cannot be modified. It is not possible to add a third staple to the set.

Install Planning

Device Configurations

The following booklet maker configurations are available:

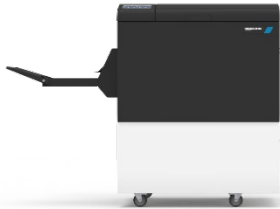

BF-435e

The Booklet Maker “base unit” in the configuration, includes the standard output tray.

NOTE: Optional 50 sheet upgrade kit not available in this configuration.



BF-450e or BF-435e with a Finishing Module

Booklet Maker with the FM-400e Finishing module adds face trimming and square folding. Considered the standard configuration. The standard output tray is moved from the booklet maker over to the output tray of the Trimmer.

When a customer orders a BF-450e the technician will enable the 50-sheet capacity during installation by installing the 50-sheet upgrade kit in the BF-435e Base unit.

NOTE: The 50-sheet version requires an FM-400e Finishing Module



BF-450e or BF-435e with Finishing Module and RCT

Production Booklet Maker with the FM-400e Finishing module and the RCT Rotate Crease Trimmer module. Adds full bleed capability, increased productivity on small sheet sizes and creasing of covers and center folds.

NOTE: FM-400e Finishing Module is required if configuration includes an RCT Module.

NOTE: The RCT3.0 and its options are only available for US.

System Dependencies and Prerequisites

The following options have conditions depending on configuration:

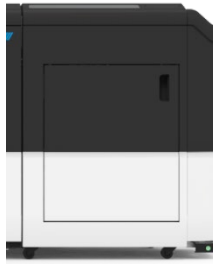

Rotate Crease Trimmer module (RCT 3.0) and its options are only available for US market.

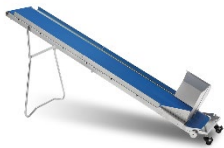

All configurations that include the RCT module can also be equipped with the **RCT Trim Waste Conveyor**



All configurations that include the FM-400e Finishing module can be equipped with the BST4000-1 **Book Stacker Module**

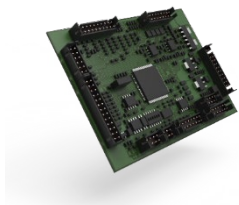

The **50-sheet upgrade kit** version requires an FM-400e Finishing Module

Printing Systems

The BF-450e/BF-435e is available for the following Kyocera printing systems.

- TASKalfa Pro 15000c

Upstream Kyocera Interface



The Plockmatic BF-450e and BF-435e attach to Kyocera's ST-9100 High-Capacity Stacker (right module in picture above) via Kyocera's AK-9150 Attachment kit (left module in picture above).

The Plockmatic BF-450e and BF-435e can also attach to Kyocera's DE-9100 Decurler unit via Kyocera's AK-9150 Attachment kit.

The Plockmatic BF-435e / 450e is fully integrated to the Kyocera printing press, therefore no additional communication box is needed (eg. RPIP Interface Box not needed).

Dimensions and weights

Footprint

Note: The optional high-capacity Belt Stacker BST4000-1 connects to the Finishing Module and can be placed either in-line or angled to the Booklet Making system. The BST4000-1 measures 1730x440mm / 68x17".

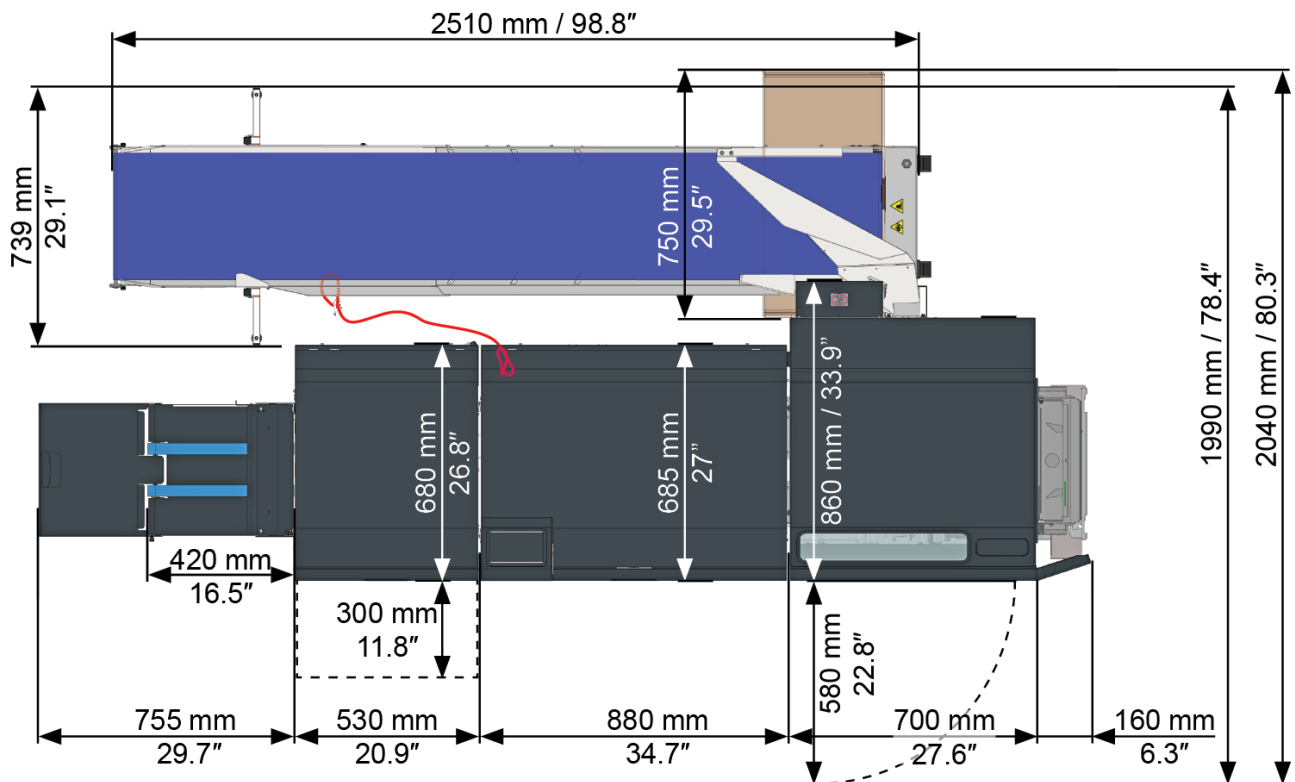

Plockmatic BF-450e/435e Production Booklet Maker floor plan

Weight and Size

All main modules are shipped in palletized cardboard boxes. Pallet jack or forklift is needed to move pallets around premises.

		BF-435e Main module	FM-400e	RCT 3.0
Item Name		Booklet maker	Finishing Module	Rotate Crease Trim module
Country of Origin		Latvia	Latvia	Latvia
Plockmatic Part no.		13209110	13309100	12209000
Kyocera Item code		1205NJ0UN0	1205NJ0UN1	1205NJ0UN2
Weight	Net	155 kg / 342 lb.	119 kg / 262 lb.	212 kg / 467 lb.
	Gross	230 kg / 507 lb.	160 kg / 353 lb.	280 kg / 617 lb.
Packing Method		Cardboard on pallet	Cardboard on pallet	Cardboard on pallet
Packing Dimension	L	1200mm / 47.3"	1200mm / 47.2"	1200mm / 47.3"
	W	800mm / 31.5"	800mm / 31.5"	1000mm / 39.4"
	H	1560mm / 61.42"	1305mm / 51.3"	1430mm / 56.3"
Number of units/CTN		1	1	1
Max Stack Height	Storage	3	3	3
	Transport	2	2	2
Printer compatibility		TASKalfa Pro 15000c	TASKalfa Pro 15000c	TASKalfa Pro 15000c, only in <u>US market</u>

		BF-450e upgrade kit	BST4000-1	Staple Cartridge*
Item Name		50 sheet upgrade kit	High-capacity belt stacker	Plockmatic production staple cartridge
Country of Origin		Latvia	Latvia	Sweden
Plockmatic Part no		13700022	4707000	760033
Kyocera Item code		1205NJ0UN3	1205NJ0UN5	1205NJ0UN9
Weight	Net	0,07 kg / 0.15 lb.	70 kg / 155 lb.	1,3 kg / 2.87 lb.
	Gross	0,1 kg / 0.22 lb.	85 kg / 187 lb.	1,2 kg / 2.65lb.
Packing Method		Carton	Carton with beams underneath (for lifting with forklift)	Carton
Packing Dimension	L	180mm / 7.1"	1500mm / 59"	225mm / 8.86"
	W	120mm / 4.8"	550mm / 21.7"	90mm / 3.55"
	H	55mm / 2.2"	540mm / 21.3"	90mm / 3.55"
Number of units/CTN		1	1	1*

* 3 Cartridges per unit

		Carepack BF-435e	Carepack FM-400e	Rail Unit	Hand Feed Tray
Item Name		Carepack BF-435e	Carepack FM-400e	Rail Unit	Hand Feed Tray
Country of Origin		Latvia	Latvia	Sweden	Latvia
Plockmatic Part no		13200013	13300006	13900003	13200008
Kyocera Item code		1205NJOUNA	1205NJOUNB	1205NJOUN7	1205NJOUN4
Weight	Net	3.6kg / 7.9lb	3.4kg / 7.49lb	3kg / 6.6lb	2.5kg / 5.51lb
	Gross	3.3kg / 7.3lb	3kg / 6.6lb	5kg / 11lb	2kg / 4.41lb
Packing Method		Carton	Carton	Carton	Carton
Packing Dimension	L	440mm / 17.3"	440mm / 17.3"	1200mm / 47.2"	525mm / 20.7"
	W	330mm / 13"	330mm / 13"	70mm / 2.8"	160mm / 6.3"
	H	130mm / 5.1"	130mm / 5.1"	600mm / 23.6"	490mm / 19.3"
Number of units/CTN		1	1	1	1

		Carepack RCT3.0	Trim Waste Conveyor	Anti-static kit
Item Name		Carepack RCT3.0	Trim waste conveyor for RCT module	Anti-static bars for RCT module
Country of Origin		Latvia	Latvia	Latvia
Plockmatic Part no		12200021	12200032	12200037
Kyocera Item code		1205NJOUNC	1205NJOUN6	1205NJOUN8
Weight	Net	3kg / 6.6 lb	30 kg / 66 lb.	TBC
	Gross	4.2kg / 9.3lb	70 kg / 154 lb.	4.5kg / 10 lb.
Packing Method		Carton	Cardboard on pallet	Carton
Packing Dimension	L	464mm / 18.3"	1200mm / 47.2"	540mm / 21.2"
	W	214mm / 8.4"	800mm / 31.5"	440mm / 17.3"
	H	164mm / 6.5"	720mm / 28.4"	380mm / 15"
Number of units/CTN		1	1	1
Remarks		Only available for <u>US market</u>		

Electrical Requirements

North America

100V - 120V, 60Hz, 4A +6% -10%,

Power consumption: 250 - 300W, idle or 400W, peak

Europe

220V - 240V, 50Hz, 2A +6% -10%,

Power consumption: 250 - 300W, idle or 400W, peak

Plockmatic provides the following cable kit for each module that requires a power cord

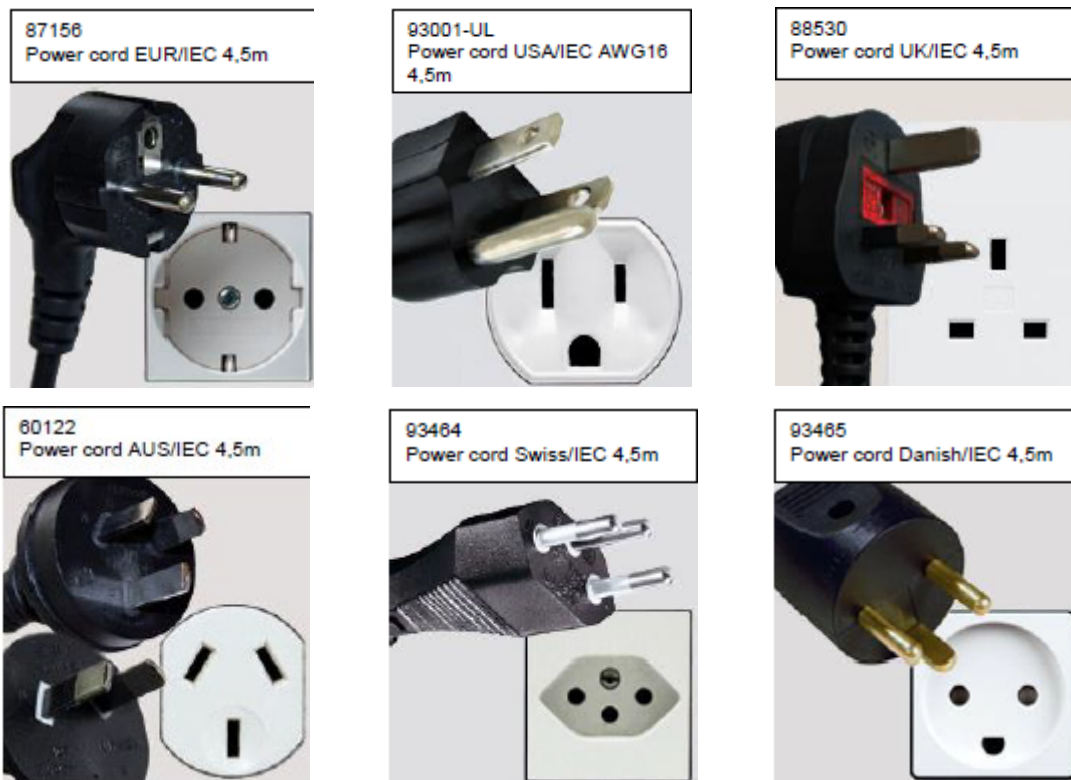

Six different types of power cord, one per geographic region, and an extension cord are included in the power cord kit. The combined length of the power cord and the extension cord is 4.28m / 168.5".

Leads supplied:

1. Power cord USA NEMA 5-15/IEC AWG-14 (80mm / 3.14" long)
2. Power cord EUR/IEC 1 mm² (80mm / 3.14" long)
3. Power cord DNK/IEC mm² (80mm / 3.14" long)
4. Power cord AUS/IEC mm² (80mm / 3.14" long)
5. Power cord Swiss/IEC mm² (80mm / 3.14" long)
6. Power cord UK/IEC mm² (80mm / 3.14" long)
7. Extension cord IEC13/C14 (4.2m / 165.3" long)

Environmental Requirements

System is tested in the following environmental zones:

Air humidity: 30% - 80% RH

Temperature: 15 – 28 degrees Celsius or 59 – 82 degrees Fahrenheit



For optimum performance of the system, environment should be kept within 40% - 50% RH and room temperature should be within 18 – 26 degrees Celsius or 64 – 78 degrees Fahrenheit.

Low humidity (below 40% RH) and lower temperatures increase the risk of static issues, and the optional Anti-Static kit should be included in the configuration if RCT is part of the system. Also storing media under humid conditions before processing may result in higher jam rate.

Estimated Installation Time

A configuration that includes an RCT, BM and FM takes one engineer 1 day to install, adjust and test before operator training can begin.

Operating Supplies

Staple Cartridge: 5000 Staples / Cartridge. Each cartridge box contains 3 cartridges in each box.

(Required 2 staple cartridges per machine)



Interchangeability

This staple cartridge is unique for Plockmatic Booklet Making systems and is not interchangeable with any other finishers. Using different staple cartridge or a copy of the original will result in **reduced penetration performance on coated media.**

Limitations

The following list of mechanical limitations have been observed during the validation process of the BF-450e/435e system.

- The BF-450e/435e system is suited for customers whose booklet making needs will not exceed an average of 30,000 booklets per month;
- If sheets entering the BF-450e/435e system are not uniform or if they are skewed, the booklet quality will vary accordingly;
- Non-stapled books should not be trimmed or square folded;
- A large amount of face trimming (>100mm) may produce excessive trim waste larger than trim waste bin. This may result in difficulty emptying trim waste and frequent production stops due to trim waste bin full;
- If booklets are made of paper lighter than 80GSM, the cover paper should be 80GSM or more to get an acceptable output result when square folding;
- Jams might be experienced when feeding sets made of several sheets of 300gsm or heavier with a shorter paper length than A3, depending on thickness and density;
- Covers may show marking along the spine of the booklet from the clamps in the Finishing Module. The more pages in the booklet, the more evident the marking;
- The booklet spine can, depending on paper quality and thickness, have different sizes of tuft at its top and bottom;
- Staple position may vary on the spine when being square formed, especially on thicker booklets. Moving staple position so staple is centered on the spine will reduce this phenomenon.
- Staple may be radius shaped (bent) when square folding. Moving staple position so staple is centered on the spine will reduce this phenomenon.
- For some sensitive, white coated stock, such as “Silk type” two sided coated paper, occasional fold roller marks may be observed on the “top side” of the book.
- For jobs with multiple sheets of 200gsm or heavier, the square folding function is recommended to be switched on for an acceptable output and to avoid feed problem at output.
- Marks from the fold knife may appear on sensitive media on the inner sheet. These marks are more common on thicker books with high toner coverage on the center sheet. Toner smearing from the fold knife can be removed/reduced by running a number of unprinted booklets of uncoated paper.
- The maximum recommended number of sheets that can be bypassed without stapling is 2 sheets of 80gsm. If there is very low friction between the sheets, running non-stapled sets may be difficult.
- Curled sheets coming out of the Upstream Device will result in increased JAM rate or paper damage. Flat Curl amount above 10 mm is outside specification. Place sheet on flat surface with the curl going up. Measure distance from surface to tip of curled sheet. If distance is equal or greater than 10 mm curl amount is out of spec.
- On some coated media, staples may not completely penetrate the set resulting in a faulty staple. If problem persists, consider changing media. Staple may not be able to penetrate the number of sheets indicated by the “Set Size Guide”. Some uncoated extra “dense” paper may show the same limitation. The following list shows examples of media where this has been observed:
 - Futura Laser Gloss 80c
 - Hammermill Laser Print
 - OPUS Gloss
 - Mondi Color Copy 200gsm
 - Sterling Premium Digital Gloss 80T
- When trimming small amount (less than 5 mm or 0.2”) in the FM module on books made from more than 2 sheets, the cut may not be clean, leaving trim waste hanging from the book.
- For some media, the legs of the staples may not be properly clinched causing the legs of the staple to be spaced away from the inner sheet. This phenomenon occurs on extra thick books over 40 sheets made

from “soft” paper (recycled and some non-coated media mostly). This phenomenon has been observed on:

- Mondi Color Copy 120gsm
- Marks around the staple position on the outside of the booklet cover may be caused by dirt deposits underneath or on the staple. Changing media may improve. Changing staple cartridge will improve.
- Grey marks around the staple area in the center of the booklet may be caused by metal dust from the staple. This phenomenon is worse on matte coated media. Changing media will improve. Cleaning the clincher area will improve. Trying to get the staple more centred inside the book may also improve.
- Grey marks around the staple area on the spine can sometimes be observed when using the SquareBack module. This may be caused by dirt deposits underneath or on the staple that are picked up by the SquareBack roller during the SquareBack process. This phenomenon occurs more for some coated media and for higher SquareBack Pressure Settings. Selecting a lower SquareBack pressure setting may improve. Switching off the SquareBack may improve. Changing staple cartridge may improve.
- An overly strong SquareBack setting and a slightly misaligned center sheet will cause wrinkles along the inner sheet spine. Selecting a lower SquareBack setting will reduce this phenomenon.
- For booklets without Face Trim, the trailing edge of the booklet may be damaged by the drive belts on the stacker. Plockmatic recommends using Face Trim or thicker sheets to minimize damage.
- Books made from 1-3 sheets of thin media longer than 420 mm may show fold quality variation. If this occurs, change media to improve quality.
- On thin books (2-4 sheets) that do not have the staple position centred in the fold line paper tear or paper damage may occur around the staple legs as the book passes through the fold rollers. This is more common when thin media (below 90gsm plain and 110gsm coated) is used. If this issue occurs, moving the staple position so it aligns with fold line might help.
- Books made folded over the long edge (menu style books) without SQF may unfold and as a result they will stack poorly on stacker. For menu style books the SQF function is recommended.
- For thick booklets with a thin cover, the cover can be “pulled back” during the registration process in the Face Trimmer. This can result in the cover sheet not being trimmed. Recommendation is to use a heavier cover whenever possible.
- Simplex printed sheets sent in-line from the printer are neither supported when using the Corner and Edge functions nor when producing booklets. This operation mode is generally less tested and may include limitations in the integration.
- If experiencing jams while running Corner and Edge stapled jobs, changing media used and storing media in a climate-controlled environment may help reduce the jam rate. Wavy and curled media will lead to a higher jam rate.
- Running jobs whose cover page has high ink coverage, may cause:

1. The fold rollers to pick up and transfer ink on other areas of the cover or to the cover of the following job(s). Using the fold rollers cleaning function regularly helps minimize this phenomenon.
2. The alignment rollers in the Finishing Module to pick up and transfer ink on other areas of the cover or to the cover of the following job(s). Keeping the alignment rollers clean will help reduce this phenomenon. When possible, it is also recommended to have the high coverage print area of the cover facing upward [A] and the low coverage print area of the cover facing downward [B] relative to how the booklet is delivered on the stacker.

NOTE: If adding toner pre-printed cover sheets to the job, it is possible to use high coverage covers.

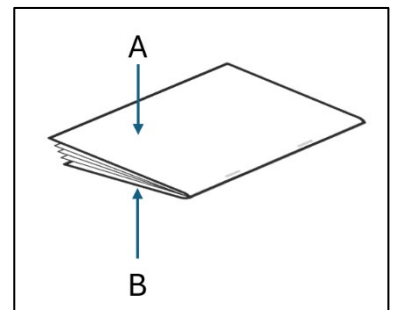

- Running jobs whose sheets have high ink coverage may cause the fold rollers to transfer ink between the pages. Using thinner paper may help reducing ink transfer.
- It is always recommended to run inkjet optimized paper.

- If ink coverage leaves the sheets too "wet", the maximum amount of sheets in a set may need be reduced. If possible, use the drier option in the printer.
- Handfeeding on most media is not supported as the special inkjet feed rollers may leave marks if the set is not handfed very precisely. The phenomenon is worse on glossy and coated media types but is also present on plain media.

RCT Limitations

The RCT module can be added to the BF-450e / BF-435e booklet maker system only if the customer fully understands and accepts the limitations associated with its installation.

The RCT is an optional module designed to:

- Perform **bleed trimming**
- **Crease** cover sheets and centrefolds
- **Rotate** smaller paper sizes from LEF to SEF for optimized productivity

When enabled, rotation and bleed trimming are performed to each individual sheet passing through the RCT's paper path.

The RCT is the first module in the booklet maker system, installed directly after the printer's exit. Every sheet used to create a booklet must pass through the RCT's paper path before reaching the Booklet Maker and Finishing Module. This applies **even if all three functions of the RCT are turned off**. If all functions of the RCT are turned off, the RCT module will still have to transport each of the sheets through its paper path.

If the RCT module is installed in a configuration, only a technician can remove it, **operators cannot uninstall an RCT** from a booklet maker configuration.

For the TASKalfa Pro 15000c the RCT is only recommended for customers producing booklets on **plain media with low ink coverage**, where paper weight does not exceed **163gsm** (43lb bond / 60lb cover / 90lb index).

A low ink coverage job is defined as a job made of body sheets made of at least 80% text.

Users are allowed to use more ink coverage on cover sheets (up to 50% ink coverage). For these jobs, it is recommended to run jobs made of a minimum of 5 sheets in total.

If adding toner pre-printed cover sheets to the job, it is possible to use high coverage covers.

If adding inkjet pre-printed cover sheets, the covers sheets cannot exceed 50% ink coverage.

If the RCT module is installed in the configuration with the TASKalfa Pro 15000c, any type of paper run through the booklet maker system must be inkjet optimized. The following recommended media types are:

- Hammermill Color Copy Premium
- Hammermill Accent Opaque

Maintenance: operators are required to clean the paper path, rollers and other elements of the RCT module that might get in contact with sheets at least once per week.

The Booklet Maker and the Finishing Module may also require a more frequent cleaning schedule as higher ink coverage is used on sheets.

It is never recommended to use rotation when BF-450e/BF-450e is used together with TASKalfa Pro 15000c.

The limitations described above apply regardless of whether the Rotation, Creasing or bleed trimming functionalities are used or not.

If a high ink coverage job or heavy media is run through a system that includes an RCT, the pictures on the next pages provide an example of the print defects that might be noticeable on the booklets.

Important notes:

1. Some of these marks might be visible also on low coverage jobs run with light paper (even lower than 163gsm).
2. The pictures display the known limitations; however, the list might not be exhaustive and other undiscovered limitations might be found out after extensive use of the module.

Defect 1: rotation defect

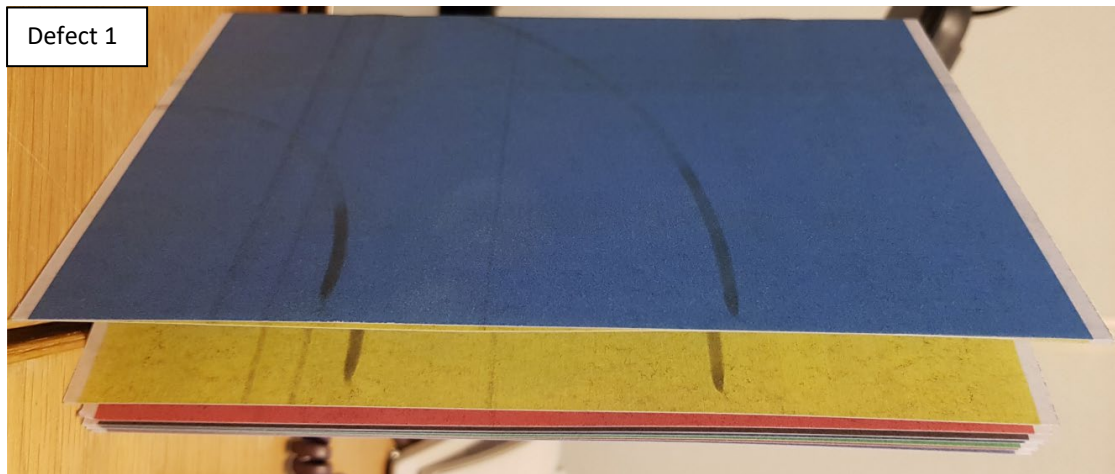

Note: defect 1 is the only defect that can be avoided by turning off rotation.

Defect 2: alignment wheel defect

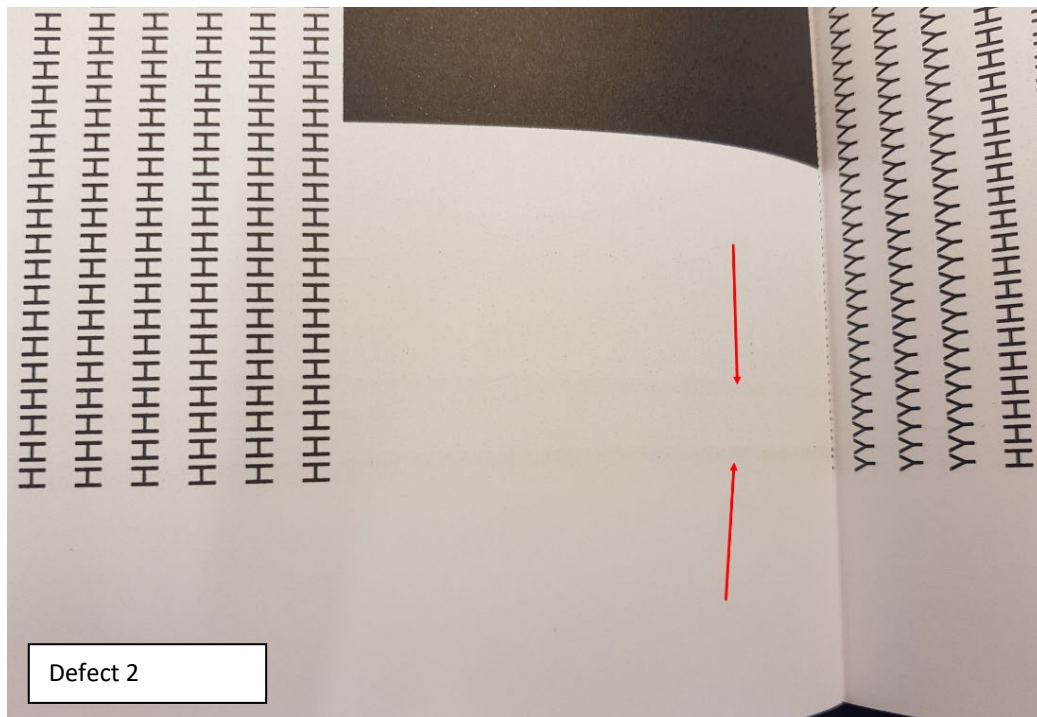

Note: this defect is visible on each sheet run through the system, regardless of whether the functionalities of the RCT module are used or not. The higher the ink coverage, the more visible this defect is. The higher the paper grammage, the more visible this defect is.

Defect 3: rubber rollers

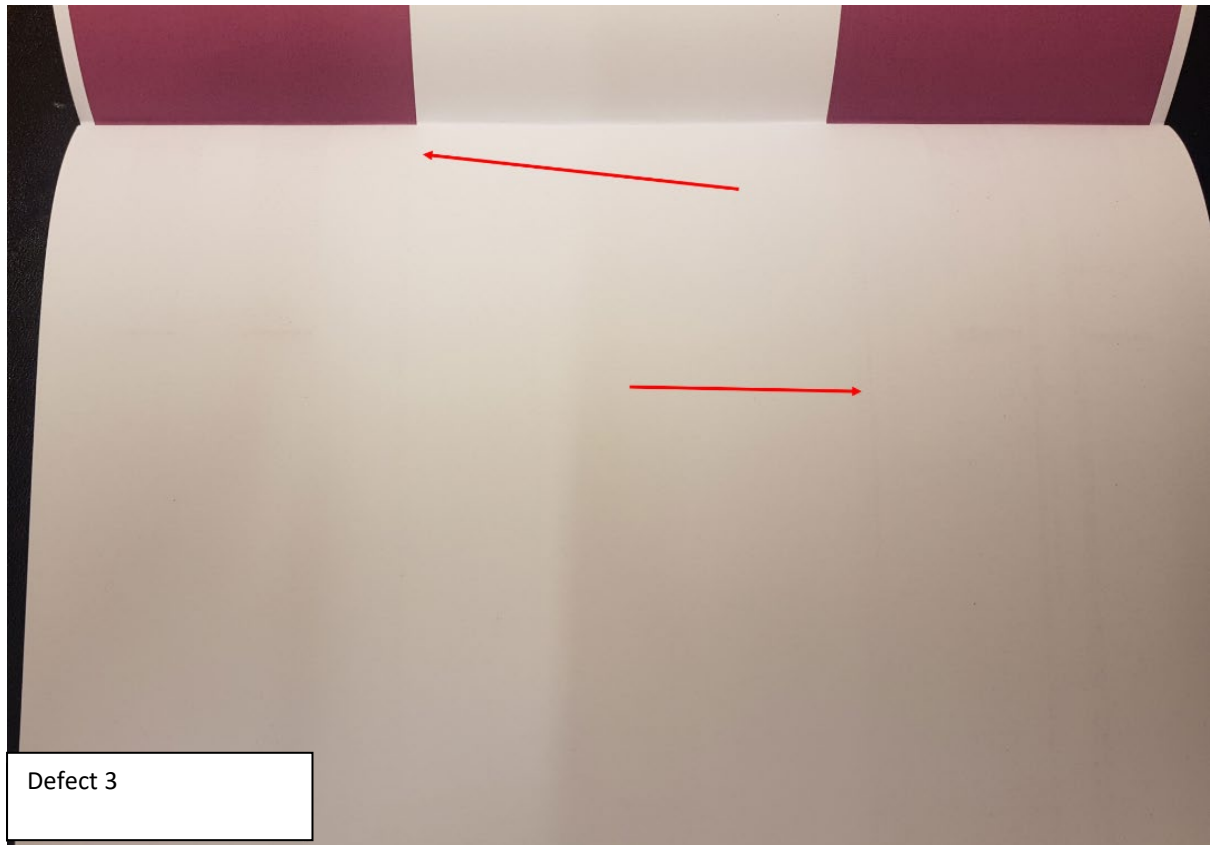

Note: this defect is visible on each sheet run through the system, regardless of whether the functionalities of the RCT module are used or not. The higher the ink coverage, the more visible this defect is. The higher the paper grammage, the more visible this defect is.

In addition to the limitations already discussed, the RCT is also subject to the following limitations:

- Heavy weight media will show image crack in the spine: pre-crease the cover in the RCT module to avoid cracking.
- Sheets may show marks from the “registration rollers” in the RCT module. Changing media will improve the situation.
- Extra heavy media (over 300gsm) may not rotate correctly in the RCT module. As a workaround, operators can try to run media in SEF mode. This may help.

- Thin media (below 110gsm) in warm and humid environments may be difficult to feed through the RCT module. The RCT may in this situation create streak creases coming from the fixing rollers and the sheets not being flat as they enter.
- For some media trim waste from the RCT can get stuck in the waste chute causing a jam. This phenomenon is worse in dry environments without climate control when the risk for static output is higher. Installing the optional Antistatic kit in the RCT may improve this situation.
- If system is installed in area with cold winters (Northern USA, Canada and Northern Europe) in a room without climate control the option Antistatic kit is recommended.
- When using side trimming, best performance is achieved if trim strips are between 10mm – 20mm
- When processing heavy media in the RCT module, limitations may occur in the sheet rotation function. These limitations can affect sheet registration after the rotation step. As a result, this may lead to skewed side trimming and/or misalignment of the crease line. In more severe cases, an increased jam rate may be observed. This behavior is typically noticeable when running media of 170 gsm or heavier. Coated Glossy media has been observed to be more susceptible to these effects.

Recommended Actions:

- Contamination of the rotation rubber rollers can exacerbate this issue. To minimize the impact, ensure that the rotation rubber rollers are cleaned regularly.
- It is recommended that the operator cleans the rotation rubber rollers at least once per week, or as needed, using a damp cloth with warm water.

If issues persist, run the job in SEF (Short Edge Feed) instead of LEF (Long Edge Feed), where possible, to avoid the rotation step.