

# DigiBook 300XL Pro

A new dimension to PUR Binding.  
Four times stronger than hot melt.

## Key Features

- 300 books per hour
- Touch screen operation complete with automatic format change.
- Pneumatic opening and closing of clamp
- Binding length (spine) from 3.93" up to 17.71"
- Spine thickness from 0.07" to 1.96"
- Spine preparation by sophisticated milling device
- Automatic cleaning and sealing of the glue head
- Retractable milling
- Patented hermetically sealed PUR application system for spine and side gluing with automatic glue cut-off
- Unique angled worksurface



PUR is the strongest, most flexible binding adhesive available and offers several additional advantages over other binding methods. When inks, coatings or digital print toners are present in the spine area these can compromise the strength of typical hotmelt perfect binding. PUR is resistant to this and will form a super-strong bond with all weights and finishes of paper stocks. In addition PUR works well with synthetic and recycled-content stock.

The DigiBook 300 is ideally suited to litho and digital printers who require short to medium runs of PUR perfect bound books to a professional standard. This innovative machine is equipped with a patented closed gluing system where the spine and side gluing is applied by a slot applicator for the utmost binding quality and accuracy.

The machine is easy to use, even by non-specialised personnel, and operated via a touch screen panel with icon graphics that allow the programming of all precision operations in just a few seconds. There are a thousand alphanumeric memories available, which enable repeat jobs to be saved for later recall, thus providing totally automatic set up.

An additional feature of the DigiBook 300 is the new and innovative glue

application system which is covered by no less than seven international patents. The application is direct and hermetically sealed, without odour or toxic fume emissions, and does not require extraction fans. It is possible to set different temperatures for the glue melting tank and the applicator giving greater flexibility and glue life. Another feature of this applicator is it can be cleaned and sealed automatically from the touch screen allowing for minimum glue wastage.

The PUR glue is applied on the book spine and on the sides by independent glue slots, each of which can be adjusted to give the best possible spine and side glue results. The quantity is determined by the height of the applicator and the pressure applied, thus allowing any kind of book to be bound with maximum ease.

The nipping press is a pneumatic system with adjustable lateral pressing force. Pressing time is also adjustable from the panel with a range from 0 to 30 seconds. The press height varies from 0 to 0.05" for optimal squaring of the spine and quality of glue application.

# DigiBook 300XL Pro

A new dimension to PUR Binding.  
Four times stronger than hot melt.



## Technical specifications

Books per hour	Up to 300
Number of clamps	1
Touch screen	Yes
Book length: Max / Min	17.71"/3.93"
Book height: Max / Min	12.59"/4.72"
Book/spine thickness	0.07" - 1.96"
Cover dimension maximum	39.37" x 17.71"
Cover dimension minimum	9.52" x 3.93"
Maximum cover weight	400gsm
Dimensions	L 97.25" x W 50" x H 66"
PUR glue tank capacity	Up to 6lb.6oz
Machine weight	1157lb.7oz
Power requirement	32amp single phase

## DigiBook 300XL Pro

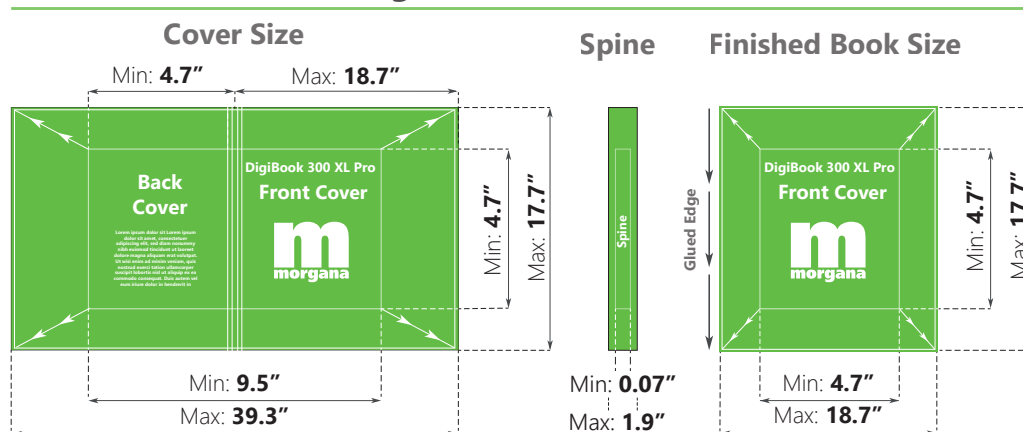

\*Disclaimer As part of our continued product improvement plan, specifications and information published here are subject to change without notice. All specifications are dependent on application, type of stock, temperature, RH and print engine used. Specifications quoted were measured on uncoated and unprinted stock. E & OE.