



Booklet Maker BM 60

Operator Manual

Doc No. T10171

BOOKLET MAKER BM 60

Operating Instruction

Booklet Maker Reference

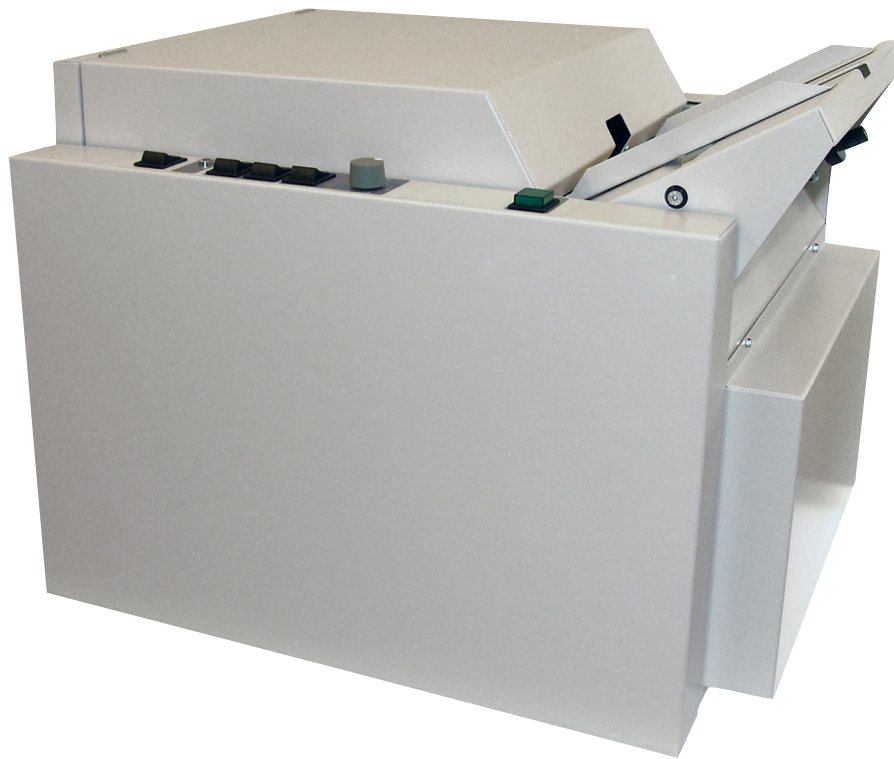

TABLE OF CONTENTS

1. Introduction

1.1 Applications.....	5
1.2 Safety notices	5
1.2.1 Notation conventions.....	5
1.2.2 General safety.....	6
1.2.3 Operational safety	7
1.2.4 Safety notes	8
1.2.5 Safety measures when using the Belt Stacker.....	9

2. Installation

2.1 Installation.....	11
-----------------------	----

3. Getting to know the Booklet Maker

3.1 Main components	13
3.2 Infeed section, upper	14
3.3 Infeed section, lower.....	15
3.4 Stapling section	16
3.5 The control panel.....	17
3.6 Accessories (optional).....	18

4. Operator instructions

4.1 Settings	19
4.1.1 Stapling and folding.....	19
4.1.2 Folding only.....	20
4.1.3 Block stapling, option 1	21
4.1.4 Block stapling, option 2	22
4.1.5 Corner stapling vertical, option 1.....	23
4.1.6 Corner stapling vertical, option 2.....	24
4.1.7 Corner stapling horizontal	25
4.1.8 Anvil settings	26
4.2 Operation	27

5. Remarks

5.1 Maintaining the rollers.....	28
5.2 Transport.....	28

6. Accessories (optional)

6.1 Delivery Tray No 600033	29
6.2 Belt Stacker No 600041	29
6.3 Adapter No 600042.....	30
6.4 Corner Stapling Guide No 600003.....	30
6.5 Loop Stapler No 607056.....	30

7. Specifications

7.1 Specification table.....	31
------------------------------	----

1. Introduction

The BM 60 automatic Booklet Maker combines features from large and advanced systems into one compact unit designed to meet the highest demands for productivity, safety and ease of operation.

1.1 Applications

1. Stapling and folding
2. Folding only
3. Block stapling
4. Corner stapling vertical
5. Corner stapling horizontal

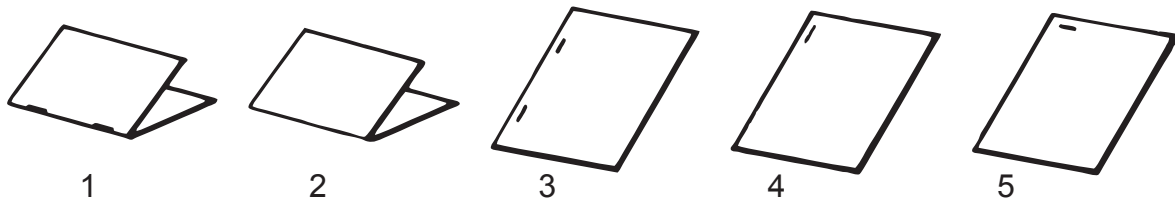

1.2 Safety notices

Prior to start up – read the Operator Manual and observe the safety notes!

Please forward all safety instructions to other users of this machine.

1.2.1 Notation conventions

Whenever necessary, the following points for attention are indicated in this manual.

WARNING:

This remark in the text means a potential danger of injuries to the operator.

CAUTION:

This remark in the text means a potential risk of machine damage.

NOTE:

This sign refers to remarks for making the operation much easier. You get practical hints to assist you in the machine operation.

1.2.2 General safety

The following points are brought to the attention of the user of this unit:

1. This machine was manufactured according to the latest technical development and the recognized safety regulations. Nevertheless, the usage of this system could pose dangers to the operator's life and limb or impair the machine functions.
2. This machine is destined for specific purpose only. Any use going beyond this specific purpose is regarded as beyond the determination. The manufacturer will not be liable for damages resulting from any use beyond the determination, unallowed operation, respectively. The user alone bears the risk.
3. For your own safety please observe the information labels on your machine and the hints given in the text.
4. The manufacturer will not be liable for modifications made at the machine on your own and damages resulting thereof.
EC declaration of conformity and the mark CE will be invalidated, if you make changes at the machine or at the individual components.
5. For all questions concerning service and repair contact your sales representative in charge.
6. The machine is to be used only by authorized and instructed persons. The responsibilities on operating the machine have to be strictly laid down and observed so that there are no unclear competences regarding safety aspects.
7. The operator's manual always has to be available at the PLACE OF USE of the machine.
8. In the interest of technical development the company reserves the right to make alterations to specifications without prior notice!

WARNING: It is the duty of the service staff to correctly instruct the operator and to point out specific dangers and possible operating errors.

NOTE: The indications like front and rear, left and right refer to the paper transport direction.

1.2.3 Operational safety

Attention to the following notes ensures the continued safe operation of your equipment.

Always connect the equipment to a properly grounded power source receptacle. In doubt, have the receptacle checked by a qualified electrician.

WARNING: Improper connection of the equipment grounding conductor can result in electrical shock.

Always follow all warnings marked on, or supplied with, the equipment.

Always locate the equipment on a solid support surface with adequate strength for the weight of the machine.

Always exercise care in moving or relocating the equipment.

Always keep magnets and all devices with strong magnetic field away from the machine.

Never use a ground adapter plug to connect the equipment to a power source receptacle that lacks a ground connection terminal.

Never attempt any maintenance function that is not specifically described in this documentation.

Never remove the covers or guards that are fastened with screws.

Never install the unit near a radiator or any other heat source.

Never override or “cheat” electrical or mechanical interlock devices.

Never operate the equipment if you notice unusual noises or odours. Disconnect the power cord from the power source receptacle and call your customer service engineer to correct the problem.

1.2.4 Safety notes

- Preserve this operator manual carefully for later use.
- Lay the power cord in a way that nobody will stumble over it. Do not place things on the cord.
- The machine should be protected against humidity.
- The vent holes serve for air circulation to protect the machine from overheating. Make sure that the holes are not covered.

WARNING: Objects or liquids must never penetrate the machine → Danger of life!

WARNING: Pull mains plug before cleaning and care!

WARNING: Observe the legal regulations of the local institutions concerning protective clothing and preventive measures.

Keep your hands off moving, rotating or cutting assemblies.

Wear proper protection for the head (e.g. hairnet) to prevent dangers caused by loosely hanging hair.

Pieces of jewellery, wristwatches or other comparable objects must not be worn during operation due to possible dangers.

NOTE: If the machine is not used over an extended period it should be unplugged to prevent damage in the case of overload.

- Do not use any fluid or aerosol purifier.
The best suitable for cleaning is a slightly moistened cloth.
- In the case of the following conditions the machine must be unplugged and checked by a qualified service technician:
 - a) Power cord or plug damaged.
 - b) Liquid has penetrated the machine.
 - c) The machine has been exposed to moisture.
 - d) The machine is not working according to the operator's manual and no improvement has been brought about with the help of the manual.
 - e) The machine has been dropped and/or the housing damaged.
 - f) The machine is showing clear signs of defects.
- For repair use only the original spare parts or those spare parts that correspond to the original parts.
- For all questions concerning service and repair contact your SALES representative in charge. In this way the operating safety of the machine is ensured.

1.2.5 Safety measures when using the Belt Stacker

WARNING: If the Belt Stacker is used and the machine is placed on a Base, the Tilt Protection bars must be installed. They are indicated in the picture below.



2. Installation

2.1 Installation

1. Place the unit on a table with suitable height for operation, unless the machine is mounted on a Base.
2. Mount the Belt Stacker or Delivery Tray on brackets (1).
WARNING: If BM 60 is placed on a table and belts stacker is used, table must reach all the way under the belt stacker, to stop machine from tilting over if heavy weight is placed on the belt stacker.
3. Connect power cord to wall outlet.



3. Getting to know the Booklet Maker

Take a few minutes to become familiar with the main components of the Booklet Maker.

3.1 Main components



1. Top cover
2. Brackets for stacker
3. Fold stop

3.2 Infeed section, upper

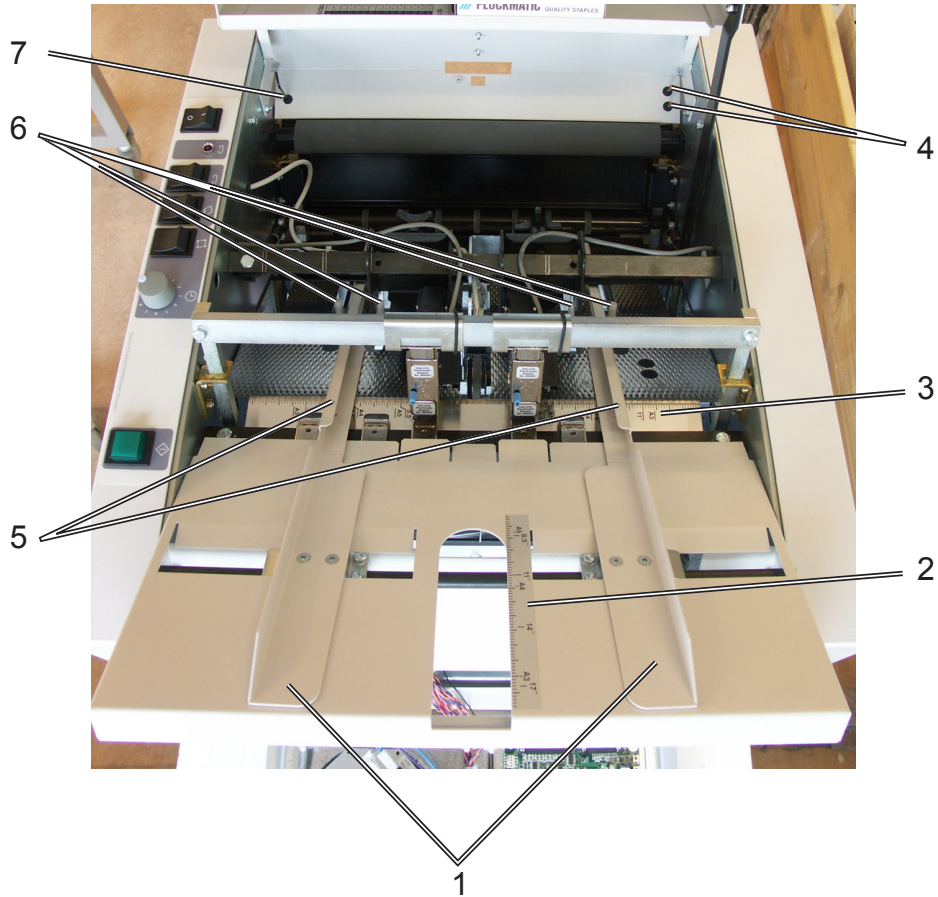

- 1. Side guides
- 2. Scale, paper length
- 3. Scale, paper width
- 4. Pins, paper stop
- 5. Holes for paper stop pins
- 6. Fingers
- 7. Allen key

(To move the side guides it is necessary to push down the fingers)

(Used to remove the fingers)

3.3 Infeed section, lower

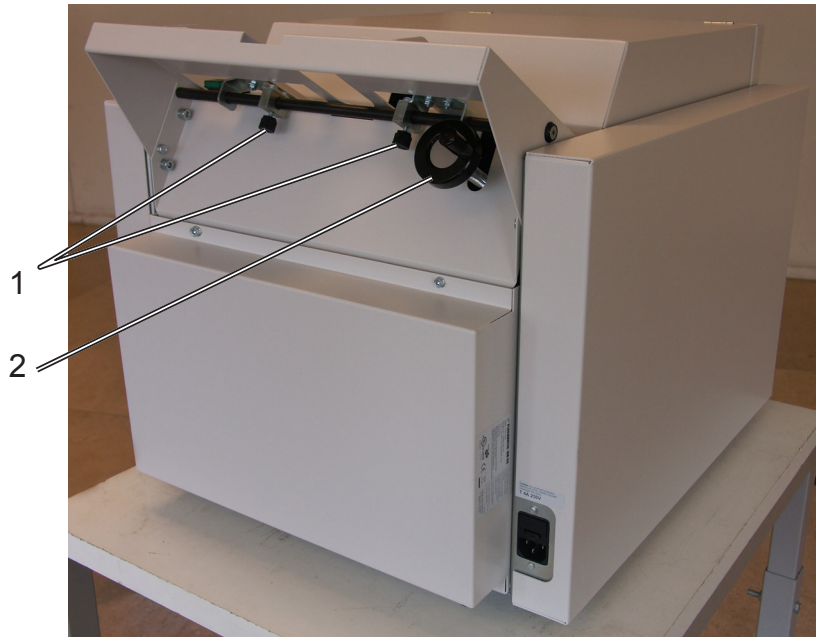

1. Screws, side guides (Used for adjustment to correct paper width)
2. Paper stop crank (Used for adjustment to correct paper length)

3.4 Stapling section

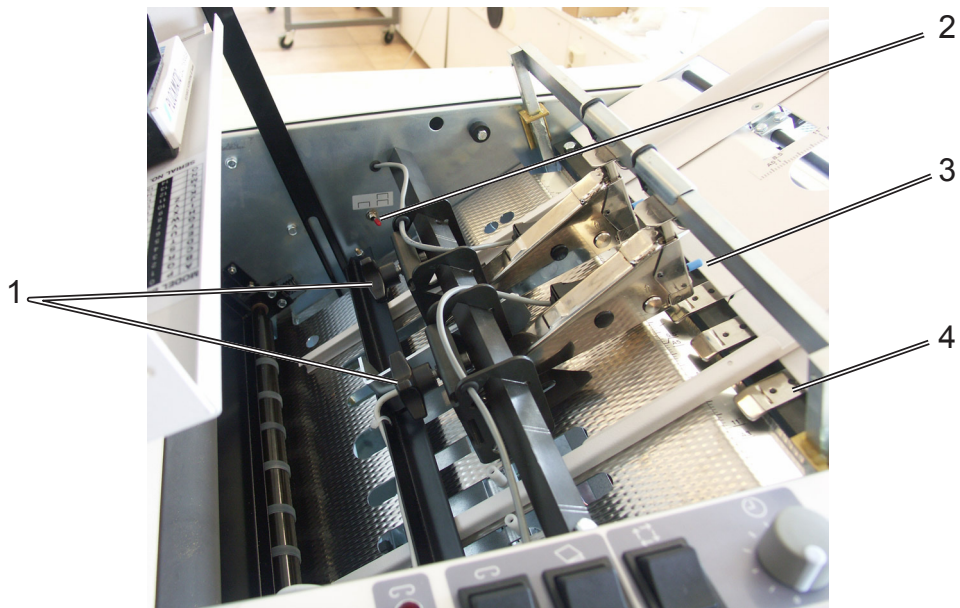

1. Knob, stapler head position
be positioned above correct anvil)
2. Double/single stapling switch
3. Stapler magazine release button
4. Anvil

(By loosening the knobs, the stapler heads can

3.5 The control panel

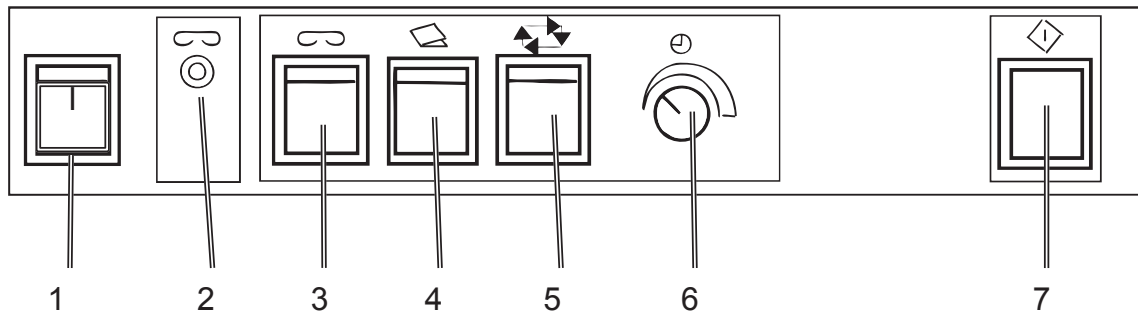

1. Power switch
2. Low staples indicator
3. Stapling ON/OFF
4. Folding ON/OFF
5. Automatic start ON/OFF
6. Time delay, for automatic start
7. Manual start button

3.6 Accessories (optional)



1

2

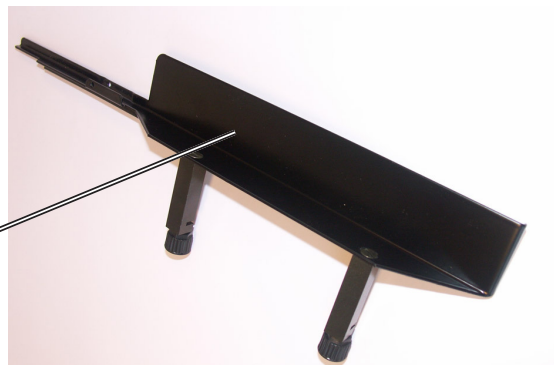

3

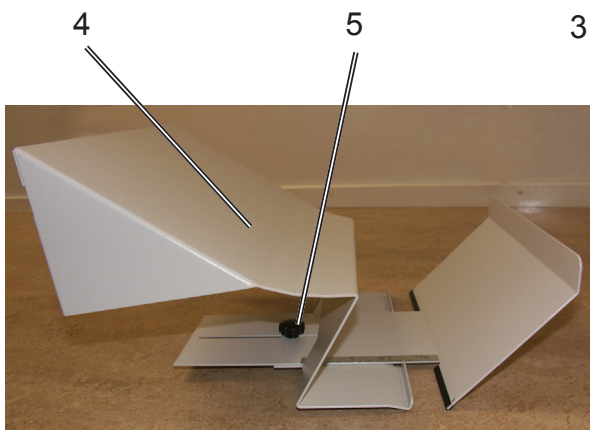

4

5

- 1. Belt Stacker
- 2. Adapter
- 3. Corner Stapling Guide
- 4. Delivery Tray
- 5. Knob, Delivery Tray
(By loosening the knob the Delivery Tray can be adjusted for correct paper size)

(By loosening the knob the Delivery Tray can be adjusted for correct paper size)

4. Operator instructions

4.1 Settings

4.1.1 Stapling and folding

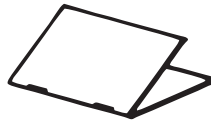

1. Open the top cover.
2. With the double/single stapling switch select double stapling.
3. Position the stapler heads above the correct anvils (check table in section 4.1.8). Position the stapler heads as in figure below, right above the anvil.

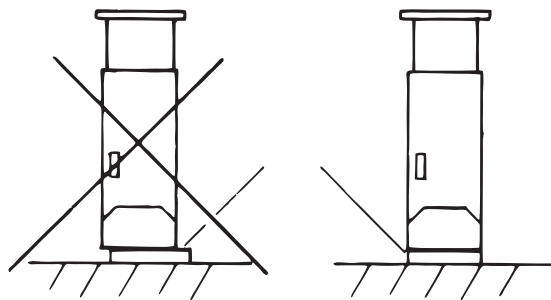

4. Adjust the side guides to proper paper size by loosening the side guide screws.
5. Insert one set.
6. Turn the paper stop crank until the trail edge of the set is in line with the scale for paper length.
7. Make the final adjustment by loosening and moving the right side guide up against the set and then back 1 mm.
8. Load the stapler magazines. By pressing the stapler magazine release button the magazine will come out.
NOTE: Use only Chisel point staples P/N 800001.
9. Close the top cover.
10. Set Delivery Tray for correct paper size according to scale by loosening the knob.
NOTE: This does not apply if you are using the Belt Stacker.
11. Set the stapling switch to **ON** position.
12. Set the folding switch to **ON** position.
13. Continue to section 4.2 OPERATION.

4.1.2 Folding only

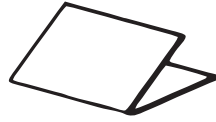

1. Follow the steps for 4.1.1 Stapling and folding except point 2, 3, 8 and 11.
2. Set the stapling switch to **OFF** position.
3. Continue to section 4.2 OPERATION

4.1.3 Block stapling, option 1

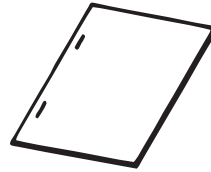

1. Open the top cover.
2. Select Double stapling with the double/single stapling switch.
3. Adjust the side guides to proper paper size by loosening the side guide screws.
4. Position the stapler heads above the correct anvils (see table in section 4.1.8).
5. Insert one set.
6. Make the final adjustment by loosening and moving the right side guide up against the set and then back 1 mm.
7. Set desired staple position with the paper stop crank.
8. Load the stapler magazines. By pressing the stapler magazine release button the magazine will come out.
NOTE: Use only Chisel point staples P/N 800001.
9. Close the top cover.
10. Set the stapling switch to **ON** position.
11. Set the folding switch to **OFF** position.
12. Flip down the fold stop to enable the sets to pass through the machine.
13. Take off the Belt Stacker or Delivery Tray. Mount the adapter on the brackets (1) on Booklet Maker and mount the Belt Stacker/Delivery Tray on the adapter (2).
14. Continue to section 4.2 OPERATION

NOTE: By using the adapter (optional) either the Belt Stacker or the Delivery Tray can be used for stacking of stapled sets.



4.1.4 Block stapling, option 2

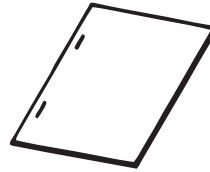

1. Open the top cover.
2. Select Double stapling with the double/single stapling switch.
3. Adjust the side guides to proper paper size by loosening the side guide screws.
4. Position the stapler heads above the correct anvils (see table in section 4.1.8).
5. Load the stapler magazines. By pressing the stapler magazine release button the magazine will come out.
NOTE: Use only Chisel point staples P/N 800001.
6. Insert one set.
7. Make the final adjustment by loosening and moving the right side guide up against the set and then back 1 mm.
8. Remove the set.
9. Mount the two paper stop pins in the holes. The pins will stop the set in correct position (in this mode the set will not be transported through the machine).
10. Close the top cover.
11. Set the stapling switch to **ON** position.
12. Set the folding switch to **OFF** position.
13. Select manual start and set time delay to minimum.
14. To operate insert one set and press the manual start button. When stapled, remove set and insert the next one.

4.1.5 Corner stapling vertical, option 1

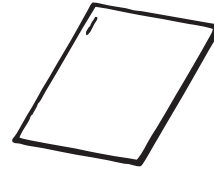

1. Open the top cover.
2. With the double/single stapling switch select single stapling.
3. Mount the Corner Stapling Guide (optional accessory p/n 600003) on the left side guide and move it as far left as possible.
4. Set stapler head 1 above the correct anvil (see table in section 4.1.8) Load stapler magazine, by pressing the stapler magazine release button the magazine will come out. Make sure the magazine in stapler 2 is empty.
NOTE: Use only Chisel point staples P/N 800001.
5. Insert one set.
6. Make the final adjustment by loosening and moving the right side guide up against the set and then back 1 mm.
7. Set desired staple position with the paper stop crank.
8. Close the top cover.
9. Set the stapling switch to **ON** position.
10. Set the folding switch to **OFF** position.
11. Flip down the fold stop to enable the sets to pass through the machine.
12. Take off the Belt Stacker or Delivery Tray. Mount the adapter on the brackets (1) on Booklet Maker and mount the Belt Stacker/Delivery Tray on the adapter (2).
13. Continue to section 4.2 OPERATION.

NOTE: By using the adapter (optional) either the Belt Stacker or the Delivery Tray can be used for stacking of stapled sets.

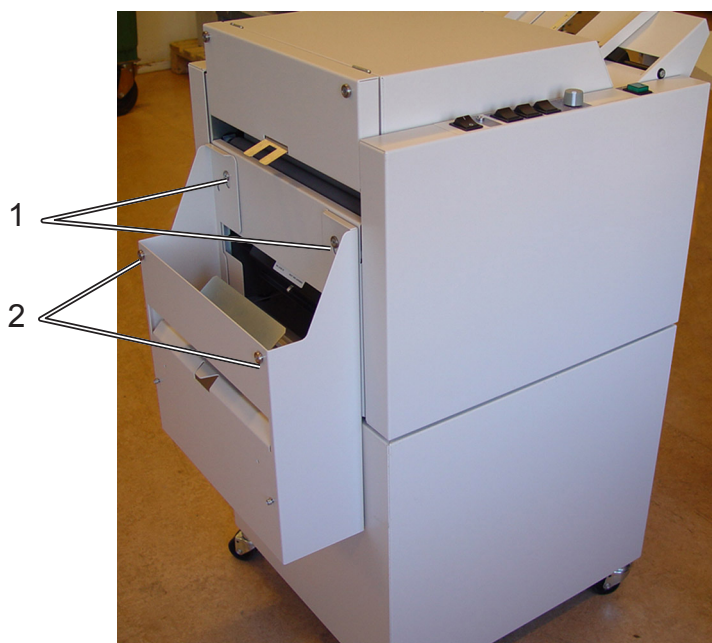

4.1.6 Corner stapling vertical, option 2

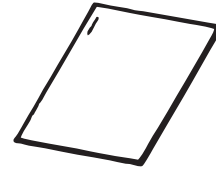



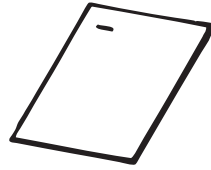

1. Open the top cover.
2. With the double/single stapling switch select single stapling.
3. Mount the Corner Stapling Guide (optional accessory p/n 600003) on the left side guide and move it as far left as possible.
4. Set stapler head 1 above the correct anvil (see table in section 4.1.8) Load stapler magazine, by pressing the stapler magazine release button the magazine will come out. Make sure the magazine in stapler 2 is empty.
NOTE: Use only Chisel point staples P/N 800001.
5. Insert one set.
6. Make the final adjustment by loosening and moving the right side guide up against the set and then back 1 mm.
7. Remove the set.
8. Mount the two paper stop pins in the holes. The pins will stop the set in correct position (in this mode the set will not be transported through the machine).
9. Close the top cover.
10. Set the stapling switch to **ON** position.
11. Set the folding switch to **OFF** position.
12. Select manual start and set time delay to minimum.
13. To operate insert one set and press the manual start button. When stapled, remove set and insert the next one.

4.1.7 Corner stapling horizontal

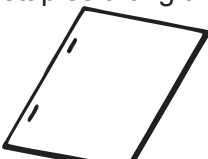
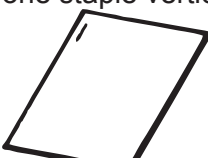

1. Open the top cover.
2. With the double/single stapling switch select single stapling.
3. Mount the Corner Stapling Guide (optional accessory p/n 600003) on the left side guide and move it as far left as possible.
4. Set stapler head 1 above the correct anvil (see table in section 4.1.8) Load stapler magazine, by pressing the stapler magazine release button the magazine will come out. Make sure the magazine in stapler 2 is empty.
NOTE: Use only Chisel point staples P/N 800001.
5. Insert one set.
6. Make the final adjustment by loosening and moving the right side guide up against the set and then back 1 mm.
7. Remove the set.
8. Mount the two paper stop pins in the holes. The pins will stop the set in correct position (in this mode the set will not be transported through the machine).
9. Close the top cover.
10. Set the stapling switch to **ON** position.
11. Set the folding switch to **OFF** position.
12. Select manual start and set time delay to minimum.
13. To operate insert one set and press the manual start button. When stapled, remove set and insert the next one.

4.1.8 Anvil settings

ANVIL WORKING FIELDS	PAPER SIZES				
	4 ¼" x 5 ½" 4 ¼" x 7"	A5 5 ½" x 8 ½"	A4 8 ½" x 11"	8 ½" x 14"	A3 11" x 17"
	USE ANVIL	USE ANVIL	USE ANVIL	USE ANVIL	USE ANVIL
1 Stapling and folding 	—	C and D	C and D	C and D	B and E
2 Folding only 	—	Switch off stapling	Switch off stapling	Switch off stapling	Switch off stapling
3 Block stapling, two staples along the side 	C and D	C and D	B and E	—	—
4 Corner stapling, one staple vertical 	—	B	A	—	—
5 Corner stapling, one staple horizontal 	—	C	B	B	A

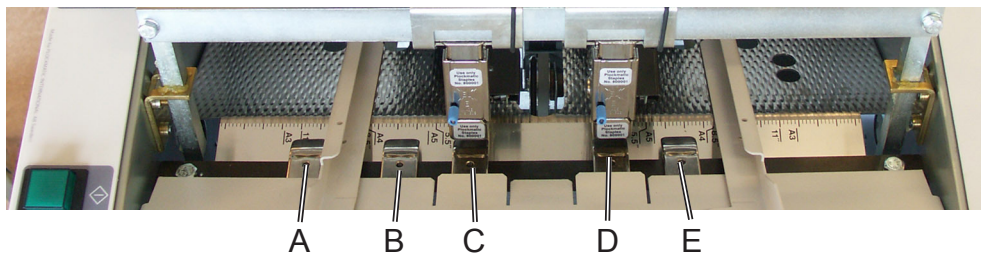

OTHER PAPER SIZES

In the table are only the most frequent used paper sizes and working fields described. Other combinations are possible.

Settings for other paper sizes can lead to that one or both side guides are blocking the fingers. If so, remove the finger/fingers in question with the allen key.

4.2 Operation

1. Being ready with the settings, select manual start and turn on the power switch.
2. Insert one set and press the manual start button and check the result. If necessary do final adjustments of paper length and staple position with the paper stop crank.
3. Select manual or automatic start.
 - Manual start: Make sure that the time delay is set to minimum. Press the manual start button for each operation.
 - Automatic start: The set will automatically be stapled as it is inserted in the Booklet Maker.

NOTE: Manual start can be used for all stapling and folding alternatives. Automatic start can be used for all alternatives except for horizontal corner stapling.
4. When operating, insert one set at a time. Align the set with your fingertip. When automatic mode is selected, set time delay to allow careful alignment.

5. Remarks

5.1 Maintaining the rollers

Grease and oil on rollers will badly affect operation. On a regular basis, clean with a rubber reactivator fluid or similar cleaner intended for rubber.

5.2 Transport

In order to avoid damages to the fold stop during transport, keep it set to A5 position.

6. Accessories (optional)

6.1 Delivery Tray No 600033

Install the Delivery Tray (1) by mounting it on the brackets (2).

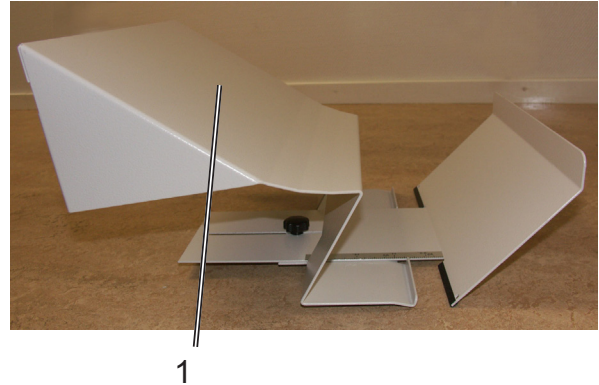
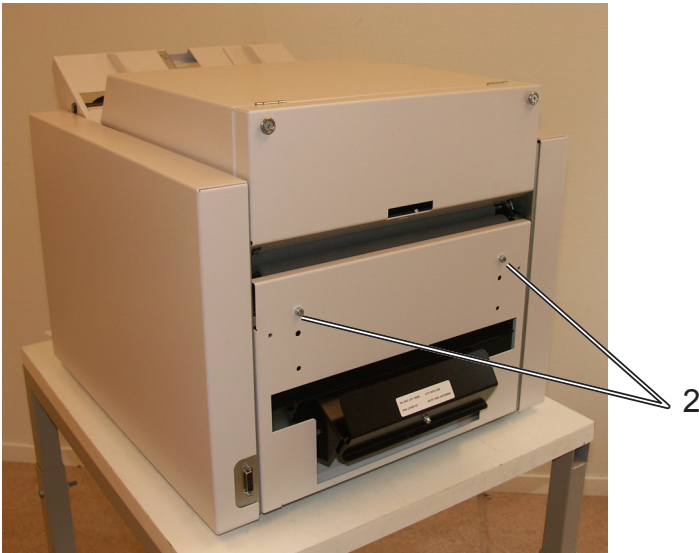

6.2 Belt Stacker No 600041

The Belt Stacker is designed for stacking of larger volumes.

Assembling:

1. Mount the Belt Stacker on the brackets (1). Secure the Belt Stacker by tightening the screws (2).
2. Connect the plug to the outlet (3).

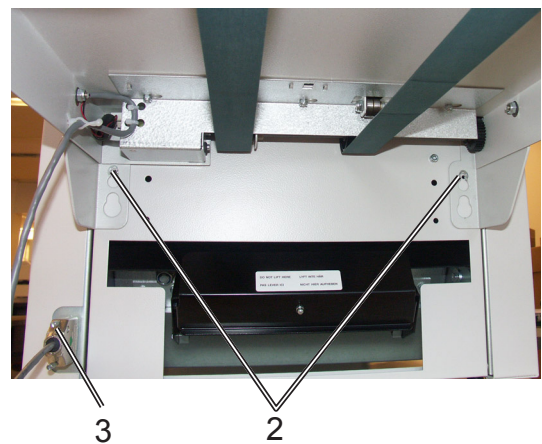

6.3 Adapter No 600042

By using the adapter either the Belt Stacker or the Delivery Tray can be used for stacking of block stapled/vertical corner stapled sets.

Assembling:

Turn down the fold stop (1). Mount the adapter on the brackets (2) and secure it with the screws. Mount the Belt Stacker on the brackets (3) or the Delivery Tray on the brackets (4).

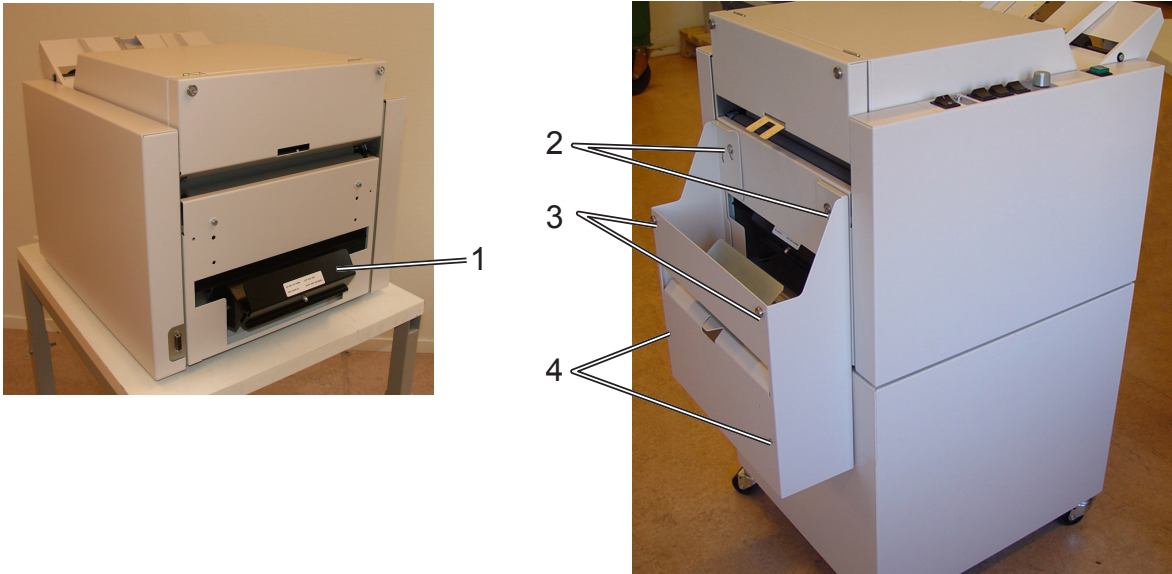

6.4 Corner Stapling Guide No 600003

Required for vertical and horizontal corner stapling.
Install it by loosening the two screws (5) and place it on the left side guide.

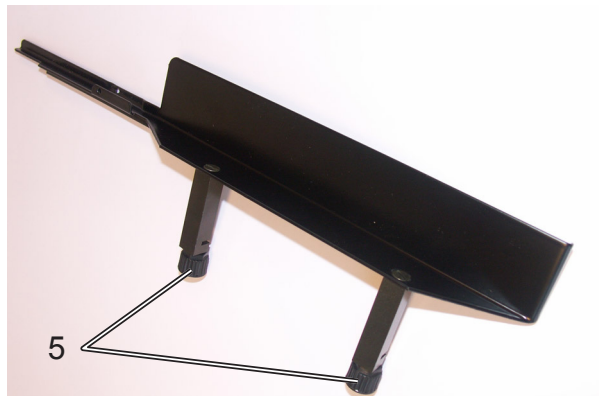

6.5 Loop Stapler No 607056

The BM 60 can be equipped with loop staplers.
For installation of loop stapling please contact your Dealer.

7. Specifications

7.1 Specification table

		BM 60
Capacity		22 sheets 80 gsm 22 sheets 20 lb bond
Speed		Up to 1800 A5 or 1400 A4 sized booklets/hour
Paper size	Min Max	138 x 210 mm, 5,5" x 8,3" 338 x 458 mm, 13,3" x 18"
Staples		210 pcs chisel point staples/magazine
Low stapler detection		Yes
Height		450 mm 17,7"
Width		500 mm 19,7"
Length		590 mm, 1230 mm incl stacker (1020 mm with stacker folded) 23,2", 48,4" incl stacker (40,2" with stacker folded)
Weight		55 kg (Without Belt Stacker) 120 lb (Without Belt Stacker)
Voltage		100, 110, 120, 127, 220, 230 V 50 – 60 Hz

