

# Technical Specification

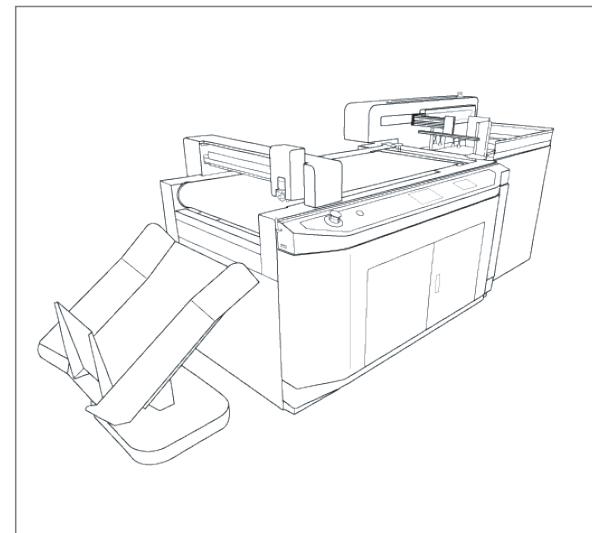

**Morgana FB9500 Pro<sup>T</sup> Automatic Flatbed Cutter** -(Comprising FB9500 Cutter/Creaser and ASF9500 Auto-Sheet Feeder)

Media sizes - sheet fed	Max: 500 x 710mm Min: 150 x 190mm
Media thickness	0.14mm (140 micron/140g/m <sup>2</sup> ) - 1mm (1,000micron/800g/m <sup>2</sup> )
Auto-sheet capacity	25kg / 217mm
Max speed/Max force	Crease: 2.5kg, Cut: 1.3kg, Speed: 1200m/s
Registration system	Vision3 - High resolution CCD vision system ARMS 9
Cut position accuracy	+/- 100 micron
Minimum PC specification	Adobe® Illustrator® CS6, CC2024 - CC2024 or CorelDRAW® X8, 2017 - 2024 Graphics Suite
ColorCut Pro 5 Plugin - PC	Adobe® Illustrator® CS6, CC2024 - CC2024 or CorelDRAW® X8, 2017 - 2024 Graphics Suite
ColorCut Pro 5 Plugin - Mac Client	Adobe Illustrator® CC 2022 - 2024. Mac operating systems: Big Sur to Sonoma
ColorCut Pro 5 Standalone - PC Only	Job server - enables jobs created by the ColorCut Pro Plugin above to be cut at any time
Power supply	220-240V AC 50/60Hz, 700W average 6.8A
Weight (unpacked)	531kg (FB9500 236kg ASF9500 295kg)
Dimensions	3140mm x 1095mm x 1225mm W D H (including media catch tray)



## Morgana FB9500 Pro<sup>T</sup> Automated Sheet-fed Flatbed Cutter/Creaser

[www.plockmaticgroup.com](http://www.plockmaticgroup.com) • email: [sales@morgana.co.uk](mailto:sales@morgana.co.uk)

\*Disclaimer As part of our continued product improvement plan, specifications and information published here are subject to change without notice. All specifications are dependent on application, type of stock, temperature, RH and print engine used. Specifications quoted were measured on uncoated and unprinted stock. E & OE.

**colorcut**  
[www.plockmaticgroup.com](http://www.plockmaticgroup.com)

# Morgana FB9500 Pro<sup>T</sup>

## Fully automated, ultra fast, unattended production, with the ColorCut FB9500 Pro<sup>T</sup> digital-die cutter/creaser

### We are proud to announce the FB9500 Pro<sup>T</sup> for creative, on-demand digital print finishing!

Developed with performance and flexibility in mind, to provide the perfect production and prototyping, finishing solution for your packaging, P.O.S.

### Market leading features

- Digitally cut any shape at up to 1200mm/sec
- Digital process means no more costly dies
- QR code driven workflow - QR code/Job Library retrieves associated cut files - even for mixed job batch sessions
- Faultless feeding system - multiple feed procedures and customisable options for advanced sheet separation, enabling the feeding phase of production to be optimised to your needs
- Scans and cuts at the same time\*!  
Concurrent task processing - \*Scans and feeds subsequent sheets while cutting/creasing the previous, all in one smooth, synchronous operation
- Up to 20% faster output - typically, a verified, 20% faster than its nearest competitor
- Unique and Patented Rear Mark Scanning System - automatically scans the underside of the sheet, and cuts and creases from the unprinted top, enabling an optimised crease on certain media
- Superb 2.5kg crease with tangential wheel creasing tool
- SmartMark registration delivers incredible accuracy - enabled via included ColorCut Pro software

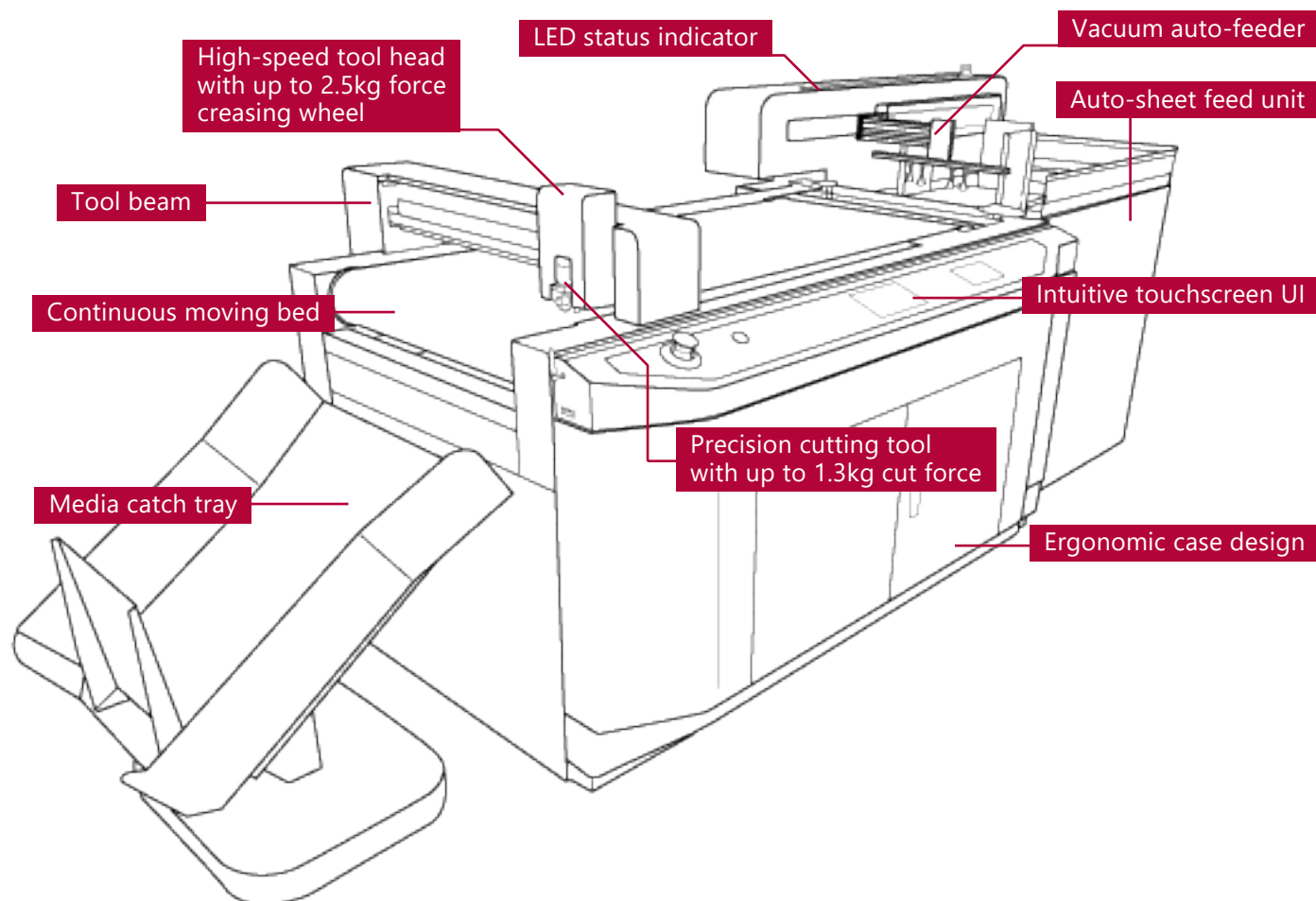

Automatic Sheet-fed Flatbed Cutter/Creaser

# Morgana FB9500 Pro<sup>T</sup>

### High-capacity and ultra-reliable feeding

The FB9500 Pro<sup>T</sup> has been designed to provide unattended operation with particular attention paid to the feeding system to ensure class-leading performance for card, vinyl labels or even tricky laminated sheets. The auto feeder accepts up to 1,000 sheets, which automatically raises and lowers as required. To prevent sheets curling (as a result of a constant air flow to the sides), the machines use an automatic air blade that fires a blast of air momentarily into the front of the stack just as the advanced vacuum feed belt lowers to collect the top sheet. To further provide a reliable feed, the vacuum feed lifts the media carrying any sheets not pre-separated by the air blade past a pair of dexterous separation fingers which dislodges them. Finally, before advancing the sheet into the cutting engine, the vacuum feed shakes the sheet, to separate any additional sheets picked up by static cling, also the vacuum feed 'jogs' briefly against the rear paper stop, creating a natural curve that helps ensure even difficult media feeds faultlessly.

### Dual tool power - digital accuracy

The digital dual tool head, includes passive contour/drag cut, with active tangential creasing wheel and applies force, individually, for both the cutting and creasing tools.



This combination of tools provides a much wider media handling capability and more defined, smoother crease for thick card up to 450 micron. The individual tool actions are controlled via the included ColorCut Pro 5 Production Studio software.

In common with the entire ColorCut family, the tools can be set to apply exact amounts of pressure and speed (up to 1200mm/s), along with total control over the application of cut, crease, perforation or kiss-cut of vector artwork lines drawn in Adobe® Illustrator® or CorelDRAW®.

**Tangential** technology enables the FB9500 Pro<sup>T</sup> to lift the tool up from the media, rotate it and lower it back onto the media. Suitable for creasing wheels to enable more **defined, smoother precise creases** - particularly good for **thicker media**.

### Ai control for automatic job retrieval and optimisation of production processes

The FB9500 Pro<sup>T</sup> is built on the foundation of our next generation of Ai based ColorCut Pro software delivering new features, functionality, control and automation, redefining how automated cutters can be used.

Customise all feeder and sheet transport parameters, including Belt speed and acceleration, 'jog' (page separation) parameters, gravity restack function and more.

Easy and simple manual use or choose fully autonomous operation from the two 2 modes users can employ for cutting files.

In **DIRECT mode**: ColorCut Pro offers unparalleled flexibility and control over cutting and production from the connected PC. When creating jobs, the ColorCut Pro Client plugin applies an auto-assigned QR code to each design, whilst auto-saving the cutting file (editable) to the ColorCut Pro Job Library.

In **HELD mode**: ColorCut Pro stores your job parameters, wrapping all the required settings into a custom held mode cut file, that can be transferred to a storage device on the cutter. This enables standalone operation, without the need for the main PC and can be cut at a later date by any operator.

The cutter checks the QR code on each sheet, retrieves the associated cut file and proceeds to cut and crease as required - even if the sheet is presented at 180°, reducing operator errors.

### Ergonomic, immersive and highly productive

The new 7" immersive touch screen with extensive Info-Control system includes a live camera preview window delivering visual feedback of QR code and smart registration marks scanning.

Plus, feature rich options that provide an advanced level of control over the auto-feeder's functionality. Useful for certain media that may require special handling or simply to optimise throughput of your chosen media.

The 7 inch immersive touch screen control panel can pivot to suit the angle desired by the operator.

A space-saving media catch tray slides away when not in use and the manoeuvrable stand ensures it is easily accommodated into any working environment.