



Morgana SC7000 Pro<sup>T</sup> and SC7000 Pro<sup>T</sup> XL  
Automatic Tangential Creasing Digital Die-Cutters

# Morgana SC7000 Pro<sup>T</sup> & XL

The **SC7000 Pro<sup>T</sup>** and **XL** models combine **ultra-reliable feeding** with an **instant job retrieval** system and **high-speed cutting** and **tangential creasing**.

These superb, and unique, dual tool cutter/creasers are a hybrid blend of flatbed, sheet-fed, tangential and contour cutting technologies, designed to deliver the benefits of each technology in a compact, affordable and productive unit.

This fully-automatic addition to your studio or production line, can produce point of sale, packaging, and kiss-cut labels in absolutely any shape you wish, in a highly productive and totally versatile way - all from your own pre-designed and printed artwork!

Equipped with an amazing dual tool head that incorporates a premium flatbed style active TANGENTIAL creasing wheel, makes this device completely unique, enabling you to cut and crease paperboard up to 0.0177" and handle a diverse range of media, including paper and synthetics inbetween.

Couple all of this easily usable convenience and functionality with the QR code driven workflow for total unattended automation and you have an extremely powerful, flexible system at your disposal, capable of rapidly processing up to 1,000 sheets, even with multiple mixed jobs in the same stack!

## Market leading features

- Digitally cut-through any shape on up to 0.0177" media, or kiss-cut sheet labels, all at up to 1060mm/sec.
- Digital process means no more costly dies or waiting time
- Auto feeder stacks up to 1,000 sheets. Up to 13.38" x 28" and up to 20.47" x 28.34" for the XL model and custom sizes - with self-centring function and air blade separation with extendable paper tray
- ColorCut Pro - Production Studio software included
- QR\* code/Job Library retrieves associated cut files - even for mixed job batch sessions or rotated sheets
- SmartMark registration delivers incredible accuracy - enabled via included ColorCut Pro software
- Retractable media tray and integral media storage area

\*QR codes and SmartMarks are generated as part of the included ColorCut Pro software plugin which integrates with vector artwork created in Adobe® Illustrator® and CorelDRAW®

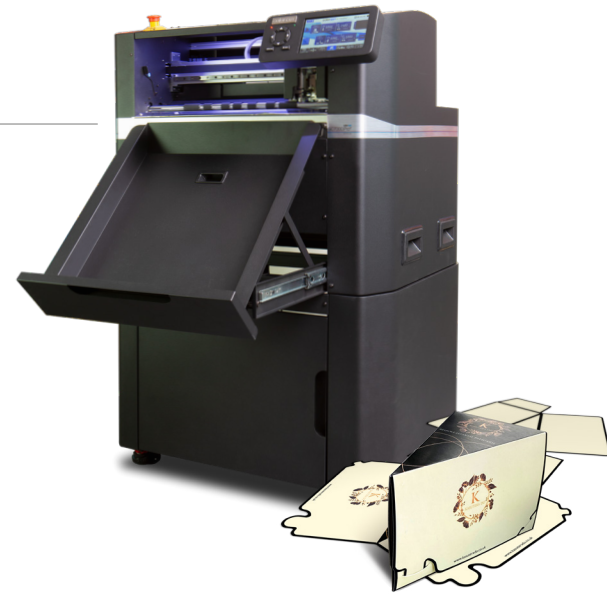

## Complete standalone operation - even with a stack of mixed jobs

- Dual tool head includes passive drag cut and active tangential crease tangential tools up to 2,500gf offers a wide range of media to be finished; FBB, card, papers, labels and synthetics
- 9th generation Vision3 CCD camera reads and instantly retrieves cut files for every sheet on the fly. Accepts a mixed stack of jobs, cutting one after the other in a seamless and uninterrupted flow
- Dual 'Grip and Drive' feed system holds media during cutting on both sides of the cutting head, enabling it to cut closer to media edges
- Superior cutting strip delivers an optimal surface for both cut-through, creasing and kiss-cutting
- SmartTags are left in the cut lines to retain the item in the sheet - leaving a tidy and manageable stack of finished sheets in the media catch tray
- High-capacity auto feeder works in conjunction with air blade separation and automated jog function, to present every sheet perfectly for the cutter, every time
- Standalone production offered with new HELD mode. Load jobs from a USB drive, view and auto scan to cut. This means that repetitive high volume jobs can be run easily without a connection to a computer - no skilled operators required!

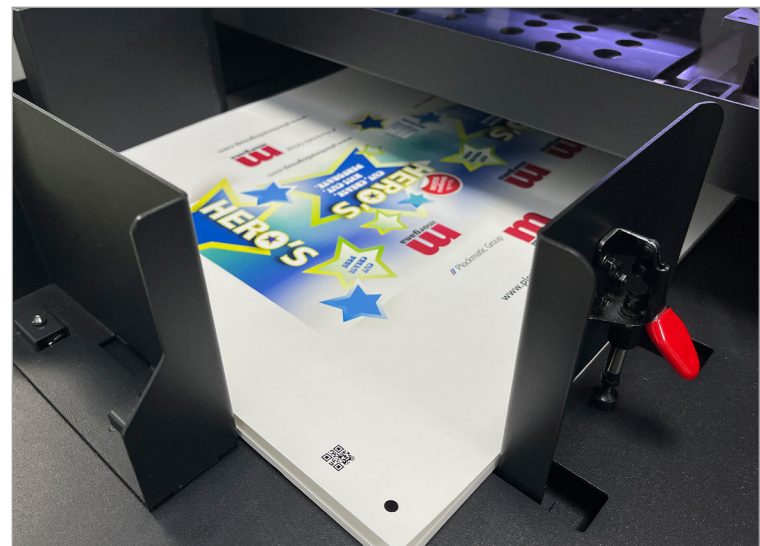

# Morgana SC7000 Pro<sup>T</sup> & XL

## High-capacity and ultra-reliable feeding

The SC7000 Pro<sup>T</sup> and XL models have been designed to provide unattended operation with particular attention paid to the feeding system to ensure class-leading performance for card, vinyl labels or even tricky laminated sheets. The auto feeder accepts up to 1,000 sheets, which automatically raises and lowers as required. To prevent sheets curling (as a result of a constant air flow to the sides), the machines use an automatic air blade that fires a blast of air momentarily into the front of the stack just as the advanced vacuum feed belt lowers to collect the top sheet. To further provide a reliable feed, the vacuum feed belt lifts the media carrying any sheets not pre-separated by the air blade past a pair of dexterous separation fingers which dislodges them. Finally, before advancing the sheet into the cutting engine, the vacuum feed belt 'jogs' briefly against the rear paper stop, creating a natural curve that helps ensure even difficult media feeds faultlessly.

## Dual tool power - digital accuracy

The digital dual tool head includes passive contour/drag cut, with active tangential creasing wheels and applies force, individually, for both the cutting and creasing tools.

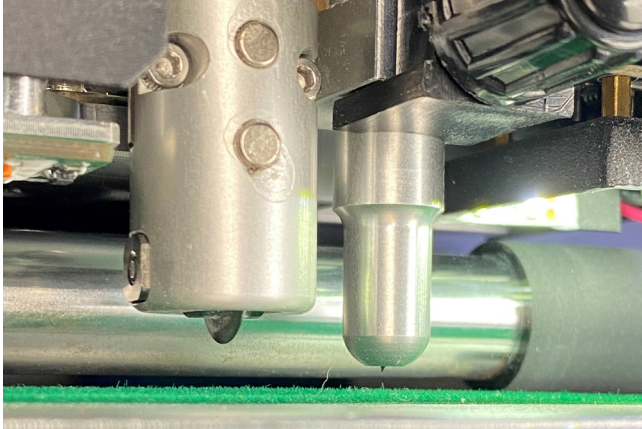

This combination of tools provides a much wider media handling capability and more defined, smoother crease for thick card up to 0.0177". The individual tool actions are controlled via the included ColorCut Pro 5 Production Studio software.

In common with the entire ColorCut family, the tools can be set to apply exact amounts of pressure and speed, along with total control over the application of cut, crease, perforation or kiss-cut of vector artwork lines drawn in Adobe® Illustrator® or CorelDRAW®.

**Tangential** technology enables the SC7000 Pro<sup>T</sup> models to lift the tool up from the media, rotate it and lower it back onto the media. Suitable for creasing wheels to enable more **defined, smoother precise creases** - particularly good for **thicker media**.

## Ai control for automatic job retrieval

The SC7000 Pro<sup>T</sup> and XL models are built on the foundation of our next generation of Ai based ColorCut Pro software delivering new features, functionality, control and automation, redefining how automated cutters can be used, easily, simply and autonomously by providing 2 modes users can employ for cutting files.

In **DIRECT mode**: ColorCut Pro offers unparalleled flexibility and control over cutting and production from the connected PC. When creating jobs, the ColorCut Pro Client plugin applies an auto-assigned QR code to each design, whilst auto-saving the cutting file (editable) to the ColorCut Pro Job Library.

In **HELD mode**: ColorCut Pro stores your job parameters, wrapping all the required settings into a custom held mode cut file, that can be transferred to a storage device on the cutter. This enables standalone operation, without the need for the main PC and can be cut at a later date by any operator.

The cutter checks the QR code on each sheet, retrieves the associated cut file and proceeds to cut and crease as required - even if the sheet is presented at 180°, reducing operator errors.

## Ergonomic, compact and mobile

The new 7" immersive touch screen with extensive Info-Control system includes a live camera preview window delivering visual feedback of QR code and smart registration marks scanning.

Plus, feature rich options that provide an advanced level of control over the auto-feeder's functionality. Useful for certain media that may require special handling or simply to optimise throughput of your chosen media.



The 7 inch immersive touch screen control panel can pivot to suit the angle desired by the operator.

A space-saving media catch tray slides away when not in use and the manoeuvrable stand ensures it is easily accommodated into any working environment.



# ColorCut Pro Server Station and Software



The optional ColorCut Pro **Server Station** streamlines production **workflow** and **automates productivity**.

The Server Station offers a much more advanced level of control with users benefiting from a host of premium features which make a quantum leap in functionality and productivity.

In the design phase, jobs created by graphic designers using ColorCut Pro Client, are saved into ColorCut Pro's Job Library.

**Production Studio** - the core application for production and cutter operation (supplied with cutter). Its easy to use interface offers powerful functions for setting tool force, speed, line actions, feeding and productivity control when used in conjunction with the printed sheets QR code to instantly retrieve the correct cut file to cut your job. Auto generated job numbers can also be used to recall the cut file, enabling an operator to load and send jobs directly to the cutter.

**Job Library Manager** - acting very much like a RIP workflow, this sophisticated software brings massive functionality to the networked library of cut job files, enabling custom job naming and identification, searching, viewing and even assigning unique or custom actions to specific QR codes or job numbers. One central and synchronised source for all ColorCut users.

**Template Maker** - this application allows networked design studio users to produce bespoke cut files to suit their projects prior to adding artwork. The designer simply enters the overall L x W x H dimensions for their package and the app calculates all the inner dimensions, folds, creases, tucks and flaps. The vector box template file is exported and the design content can be added on another layer, within Adobe® Illustrator® or CorelDRAW®.

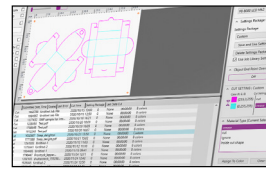

Job Library Manager

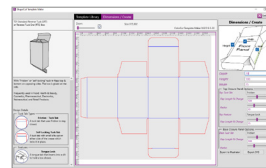

Template Maker carton design application

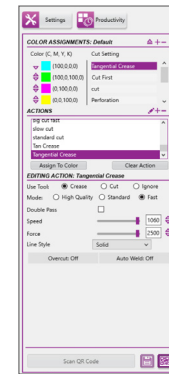

Tool settings and functions

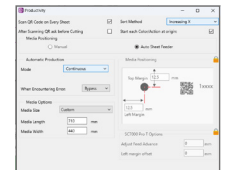

Productivity - sheet control

## Technical Specifications

### Morgana SC7000 Pro<sup>T</sup> and SC7000 Pro<sup>T</sup> XL Auto Sheet Cutters

Max media size	13.38" x 27.9"   XL model: 20.47" x 28.34"
Effective contour cutting area	13" x 27.55"   XL model: 20" x 27.56"
Crease capability	Tangential wheel 5.5lb (2,500gf) Max 0.0177"
Auto-sheet capacity	4.13" stacker height (Up to 1,000 sheets of 20lb bond media for auto-sheet feed)
Max weight	33lb   XL model: 66lb
Type of cut	Die-Cut (with tags), Half Cut (Kiss-cut) & Perf
Max. speed	1060mm (42") per second
Weight (unpacked) inc. stand	320lb   XL model: 386lb
Power supply	100-240v 50/60Hz, 100W average (320W peak)

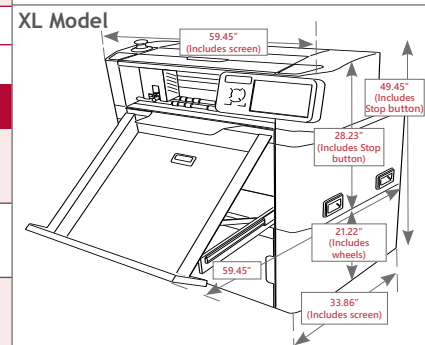
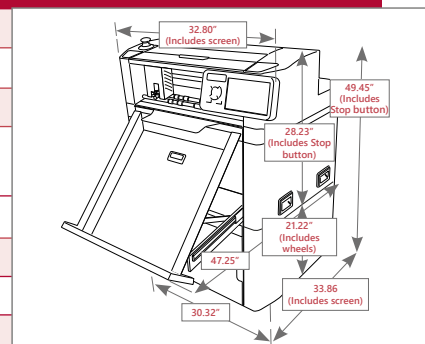

### Software and PC Specification

ColorCut Pro 5 Plugin - PC	Adobe® Illustrator® CS6, CC2024 - CC2024 or CorelDRAW® X8, 2017 - 2024 Graphics Suite
ColorCut Pro 5 Plugin - Mac Client	Adobe Illustrator® CC 2022 - 2024. Mac operating systems: Big Sur to Sonoma
ColorCut Pro 5 Standalone - PC Only	Job server - enables jobs created by the ColorCut Pro Plugin above to be cut at any time
Minimum PC specification	Windows® 10/11 Pro x64 bit. 4GB of RAM (8GB recommended). Monitor res: 1280 x 960 min