

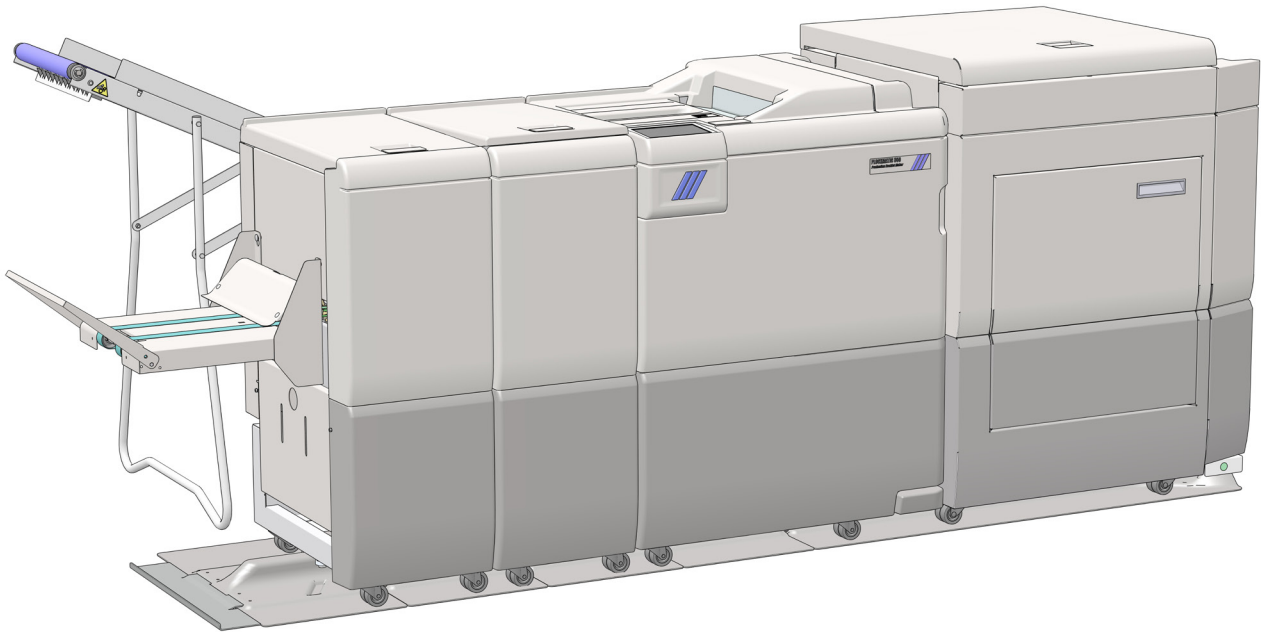

Plockmatic 350e/500e Production Booklet Maker

Operating Instruction Stapler Folder Reference



Read this manual carefully before you use this product and keep it handy for future reference.
For safety, please follow the instructions in this manual.

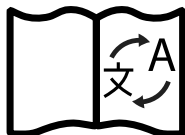

Scan the QR code to access translated versions of this manual in German, Italian, French, and Spanish.

Visit <https://plockmaticgroup.com/myfinisher/pbm350e-ricoh/> to view the manual in your preferred language.

Introduction

This manual contains instructions on the operation and maintenance of this machine. To get maximum versatility from this machine all operators should carefully read and follow the instructions in this manual. Keep this manual in a handy place near the machine.

Please read the Safety Information before using this machine. It contains information related to USER SAFETY and PREVENTING EQUIPMENT PROBLEMS.

How to read this manual

Notation conventions

Whenever necessary, the following points of attention are indicated in the documentation for this product.

WARNING:

Indicates a potentially hazardous situation which, if instructions are not followed, could result in death or serious injury.

CAUTION:

Indicates a potentiality hazardous situation which, if instructions are not followed, may result in minor or moderate injury or damage to machine or property.

NOTE:

This sign refers to:

- *Remarks for making the operation much easier. You get practical hints or knowledge to assist you in the machine operation such as:*
- *Preparations required before operating*
 - *How to prevent papers from being misfed or damaged*
 - *Precautions required or actions to take after misoperation*
- *Limitations like numerical limits, functions that cannot be used together or conditions, under which a particular function cannot be used or obtained.*
- *Information.*

[] Keys that appear on the machine's User Interface.

Safety Information

When using this machine, safety precautions should always be followed.

General Safety

WARNING

- This equipment is not suitable for use in locations where children are likely to be present.
- Only connect the machine to a mains power supply of the correct voltage with a good earth-connection; as advised by your service engineer at the time of installation. Improper Earthing of the equipment can result in electrical shock. The correct machine voltage is shown on the label at the mains power supply input on the rear of the machine. If the machine is connected to the wrong supply, the warranty is cancelled. This machine is destined for specific purpose only. Any use going beyond this specific purpose is regarded as beyond the determination. The manufacturer will not be liable for damages resulting from any use beyond the determination, unallowed operation, respectively. The user alone bears the risk.
- Do not make arbitrary changes or modifications to the machine. The manufacturer will not be liable for modifications made to the machine on your own and damages resulting thereof. The EU/UK Declaration of Conformity and the CE/UKCA mark will be invalidated if you make changes to the machine or to the individual components.
- Operators are never allowed to override or bypass electrical or mechanical interlock devices. Trained technicians are allowed to use interlock cheaters only when instructed to do so. Do not expose fingers or other parts of the body to moving, rotating, or cutting devices when running the machine with the interlock cheater installed. Do not wear ties, lanyards or other things that might get trapped into the rollers and cause injuries. Do not change, adjust, or tamper with the safety interlock devices fitted to the machine. Machine including UV-Light should never be bypassed by operator or trained technicians. Permanent eye damage could occur.
- The machine is to be used only by authorized and instructed persons. The responsibility on operating the machine must be strictly laid down and observed so that there are no unclear competences regarding safety aspects.
- Vent holes serve for air circulation to protect the machine from overheating. Make sure that the holes are not covered.
- Always locate the equipment on a solid support surface with adequate strength for the weight of the machine. Make sure the machine is located on a level floor and that there is enough work area around it.
- To protect against fire hazard, replace fuses with those of the same type and rating. Do not change fuses before the machine is disconnected from the main power supply. Refer to the product's documentation for the correct procedure.
- Do not expose the equipment to sudden temperature variations that can cause condensation.
- Operators and technicians must be familiar with the safety information detailed in this safety pamphlet and in the product's documentation.
- To avoid hazardous situations, like for instance electric shock or danger while exposed to moving, rotating or cutting devices, do not remove any covers, guards or screws other than those specified in the product's documentation and before the machine is disconnected from the main power supply.
- Always use only the power cord intended for the machine.
- Never connect plugs unless instructed so. Never connect plugs that have a different shape / number of pins.

Safety during operation

WARNING

- Do not expose body parts, loose hanging hair or clothing to moving, rotating or cutting parts.
- If any adjustment or operation check has to be made with exterior covers off or open while the main switch is turned on, keep hands away from electrical or mechanically driven components.
- Note that components of the system and peripherals can be supplied with electric voltage even if the main power switch is turned off and the power cord is disconnected.

continued on next page

Safety during operation, continued

- Turn off the power and disconnect the power plug (by pulling the plug, not the cable) if any of the following conditions exists:
 - Objects are dropped into the equipment.
 - Liquids are spilled inside the equipment.
 - You suspect that your equipment needs service or repair.
 - Covers are damaged, loose or missing.
 - You notice unusual noises or odors when operating the equipment.
 - If the power cable or plug is worn out or otherwise damaged.
 - Before cleaning and care (unless otherwise specifically instructed).
- Do not remove covers or guards that are fastened with screws.
- Machines with open (non-covered) automatic sheet feeders pose a crush/pinch hazard. Keep away from these areas when the machines are operating.
- Machines with exposed cutting carriages and heads pose a crush/pinch hazard. Keep away from the moving carriages and ensure that these machines are inaccessible to children during operation. Never leave these units switched on without supervision.
- If an emergency stop button is on the machine – do not use the button for regular operation. It is designed for immediate stop solely for emergency situations to ensure the safety of all individuals involved.

CAUTION

- *The product must be installed, relocated and maintained by a customer service representative who has been properly trained on the product.*
- *Remove paper from inside the machine and close all covers before undocking or relocating the product. Use caution: the product is heavy, could be subject to a tilt hazard and tip over.*
- *Always follow all warnings marked on, or supplied with, the product.*
- *When you disconnect the power plug from the wall outlet, always pull the plug (not the cable).*
- *Disconnect the power cord before you move the machine. While moving the machine, always exercise care and make sure that the power cord will not be damaged under the machine.*
- *Do not move the machine while the machine is running.*
- *Do not open covers while the machine is running.*
- *Do not switch off the power while the machine is running. Make sure the machine cycle has ended.*
- *Lay the power cord in a way that nobody will stumble over it. Do not place things on the cord.*
- *Never attempt any maintenance function that is not specifically described in the product's documentation.*
- *Always keep magnets and all devices with strong magnetic fields away from the machine.*
- *If the place of installation is air-conditioned or heated, do not place the machine where it will be:*
 - *Subject to sudden temperature changes.*
 - *Directly exposed to cool air from an air-conditioner.*
 - *Directly exposed to heat from a heater.*
- *If the machine is not used over an extended period of time, it should be unplugged to prevent damage in case of overvoltage.*
- *Do not operate the equipment if you notice unusual noises or odors. Disconnect the power cord from the power source and call your authorized technician to correct the problem.*

Electromagnetic compliance

This device complies with Part 15 of the FCC rules.

Operation of this equipment in a residential environment could cause radio interference.

Notes for handling Lithium and Lead batteries

CAUTION

- *Danger of explosion if batteries are incorrectly replaced.*
- *Replace only with the same or equivalent type recommended by the manufacturer.*
- *Dispose of used batteries according to the manufacturer's instructions.*

continued on next page

Safety Information, continued

Description of Safety/Warning labels in the product























<p>1</p>  <p>Crushing Hazard Risk for crushing or squeezing body parts.</p>	<p>2</p>  <p>Cutting Hazard Sharp objects inside machine.</p>	<p>3</p>  <p>Entanglement Hazard Risk for loose hanging hair, jewelry, or clothes to get caught.</p>		
<p>4</p>  <p>Hazardous Voltage High voltage inside machine.</p>	<p>5</p>  <p>Do Not Step A surface of the machine not to step/stand upon.</p>	<p>6</p>  <p>Hot Surface Do not touch with bare hands.</p>	<p>7</p>  <p>Protective gloves Protective gloves must be worn.</p>	<p>8</p>  <p>Hearing Protection Hearing Protection must be worn.</p>
<p>9</p>  <p>Tight clothes Tight clothes must be worn.</p>	<p>10</p>  <p>Earth / Ground Always ground the equipment.</p>	<p>11</p>  <p>Warning / Caution Indicates a generic warning or caution.</p>	<p>12</p>  <p>Laser Hazard Laser beam: do not stare into beam.</p>	<p>13</p>  <p>Tropical conditions Use only in non-tropical conditions.</p>
<p>14</p>  <p>Pinch Point Hazard Risk for pinching or squeezing body parts.</p>	<p>15</p>  <p>Respirator mask Respirator mask, suitable for removing used glue, must be worn.</p>	<p>16</p>  <p>Earth continuity Shows earth connection point. A separate earth connection needs to be fitted during installation.</p>	<p>17</p>  <p>Read user or service manual Do not operate unless you have read and understood the user manual. Refer to service manual for more information.</p>	
<p>18</p>  <p>Altitude Do not use at altitudes over 2000m above sea level.</p>	<p>19</p>  <p>High touch current Follow specific instructions in install manual.</p>	<p>20</p>  <p>Tilt hazard The equipment might tip over under certain circumstances.</p>		
<p>21</p>  <p>UV Light Hazard UV lights can cause skin burns, eye damage, including permanent blindness and skin cancer.</p>	<p>22</p>  <p>Scandinavian Earthing Label Connect equipment only to an earthed (grounded) outlet.</p>	<p>23</p>  <p>Eye protection Eye protection, against possible splashes of glue, must be worn.</p>		

TABLE OF CONTENTS

What You Can Do With This Machine	11
Guide To Components	13
Booklet Maker	13
User Interface	16
Control Panel.....	16
Options	19
Rotate Crease Trim Module.....	19
Booklet Maker	24
Alive logo.....	24
Cover Feeder	25
BookFold Module	26
Trimmer.....	28
BST4000-1 Belt Stacker Module	30
BST4000-1 Principle of Operation.....	31
Trim Waste Conveyor	32
1. Basics	33
Turning On / Off the Main Power	33
RCT, Booklet Maker, BookFold Module, Trimmer & BST Module.....	33
Change staple cartridges and Check stapler	34
Change left/right staple cartridge(s).....	34
Check left/right stapler	35
Loading Covers into theCover Feeder	35
Removing trim waste from trimmer blade area	37
Setting up the Belt Stacker	38
Right-angled mode	38
Setting up the Belt Stacker, continued	39
Straight mode	39
Detaching / Attaching the Trim Waste Conveyor	40
Detaching the Trim Waste Conveyor	40
Attaching the Trim Waste Conveyor	41
Docking / Undocking the Booklet Making system	42
Docking.....	42
Undocking.....	43
2. Making Booklets	45
Guided Start	45
Guided Start, step by step	45
Changing settings	48
General procedure	48
Basic settings	48
Input Sheet Size	48
Selecting standard paper sizes	48
AUTO sheet size	49
Custom input sheet size	49
Finished Booklet Size	49
Auto trimming	49
Custom booklet size	50

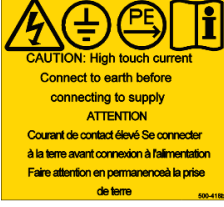
Customizing settings	51
Staple.....	51
Selecting stapling On or Off	51
Adjusting staple position.....	51
Fold position	52
Adjusting fold position	52
Cover	52
General.....	52
Cover.....	53
Air Separation.....	53
Double Sheet Detection	53
Purge Cover	54
Protection sheet	54
BookFold.....	54
General.....	54
Selecting BookFold pressure setting.....	55
Crease	56
Crease Mode.....	56
Crease position	56
Fine-tuning booklet appearance	57
Set registration (fine adjustment)	57
Bleed Trimmer - Asymmetric Side Trim.....	58
Bleed Trimmer - Cover Adjust	58
On-line/Off-line	59
Off-line mode	59
On-line mode	59
Begin On-line Production	60
3. Tools	61
The Tools screen.....	61
Stacker full detection	61
Units.....	61
Software version	62
Precision Fold	62
Paper path light.....	62
Language	63
Service mode.....	63
Adjust Trimmer registration.....	63
Set sheet count.....	64
Fold delay	64
Sheet feeder	64
Sensitive Staple	65
Auto Rotate.....	65
BookFold offset.....	65
4. Jobs	67
Handling jobs	67
Saving a Job	67
Opening and handling stored Jobs	68
5. Clearing Misfeed(s)	69
Clearing misfeed(s)	69
General	69

RCT Module	70
Clearing misfeed(s) in the paper path.....	70
Infeed “A” area and exit “D” area.....	70
Registration and creaser area.....	71
Booklet Maker	72
Clearing misfeed(s).....	72
Inside the Booklet Maker.....	72
Clearing misfeed in folder area.....	73
Cover Feeder	74
Clearing misfeed(s) in vertical transport area.....	74
BookFold Module	75
Clearing misfeed(s).....	75
Inside the BookFold Module.....	75
Trimmer	76
Clearing misfeed(s).....	76
Clearing misfeed in input area.....	76
Clearing misfeed in exit area.....	77
Belt stacker	78
Clearing misfeed(s).....	78
Clearing misfeed on belt stacker.....	78
6. Troubleshooting	79
Fault codes	79
General.....	79
RCT fault codes.....	79
Booklet Maker fault codes.....	80
Cover Feeder fault codes.....	81
BookFold Module fault codes.....	82
Trimmer fault codes.....	83
Belt stacker fault codes.....	83
General fault codes.....	84
Clear Misfeed(s).....	84
Close cover(s).....	84
Empty stacker!.....	84
7. REMARKS	85
Do’s And Don’ts	85
Where to put Your Machine	86
Machine environment.....	86
Power connection.....	86
Access to machine.....	87
Maintaining Your Machines	88
Cover Feeder.....	88
Cleaning feed rollers and paper separator pad.....	88
BookFold Module.....	89
Cleaning feed belts.....	89
Pressure springs.....	90
RCT Module.....	91
Cleaning the paper path transportation nip rollers (12x).....	91
Cleaning the fixing rollers (3x).....	92
Cleaning the registration cross roller (4x) & friction tires (4X).....	93
Cleaning the rotator rollers (2x).....	94
Cleaning the paper path sensors (5x).....	94

Cleaning of creaser tools (2x)	96
Adjustment of Bleed Trimmer registration angle (parallel cut).....	97
Adjustment of Creaser registration angle	98
Best practices for the PBM350e/PBM500e system	99
Limitations of the PBM350e/PBM500e system	100
8. Specification	105
Machine Specifications.....	105
PBM RCTe Rotate Crease Trim Module (option).....	105
PBM350e/PBM500e Booklet Maker	106
Plockmatic Cover Feeder (option)	107
PBM Trim Module (option)	107
PBM BookFold Module (option).....	108
BST4000-1 Belt Stacker Module (option)	108
Trim Waste Conveyor (option)	109
System Set Size Guide.....	109
Cables, plugs and jumpers	113
INDEX.....	114

What You Can Do With This Machine

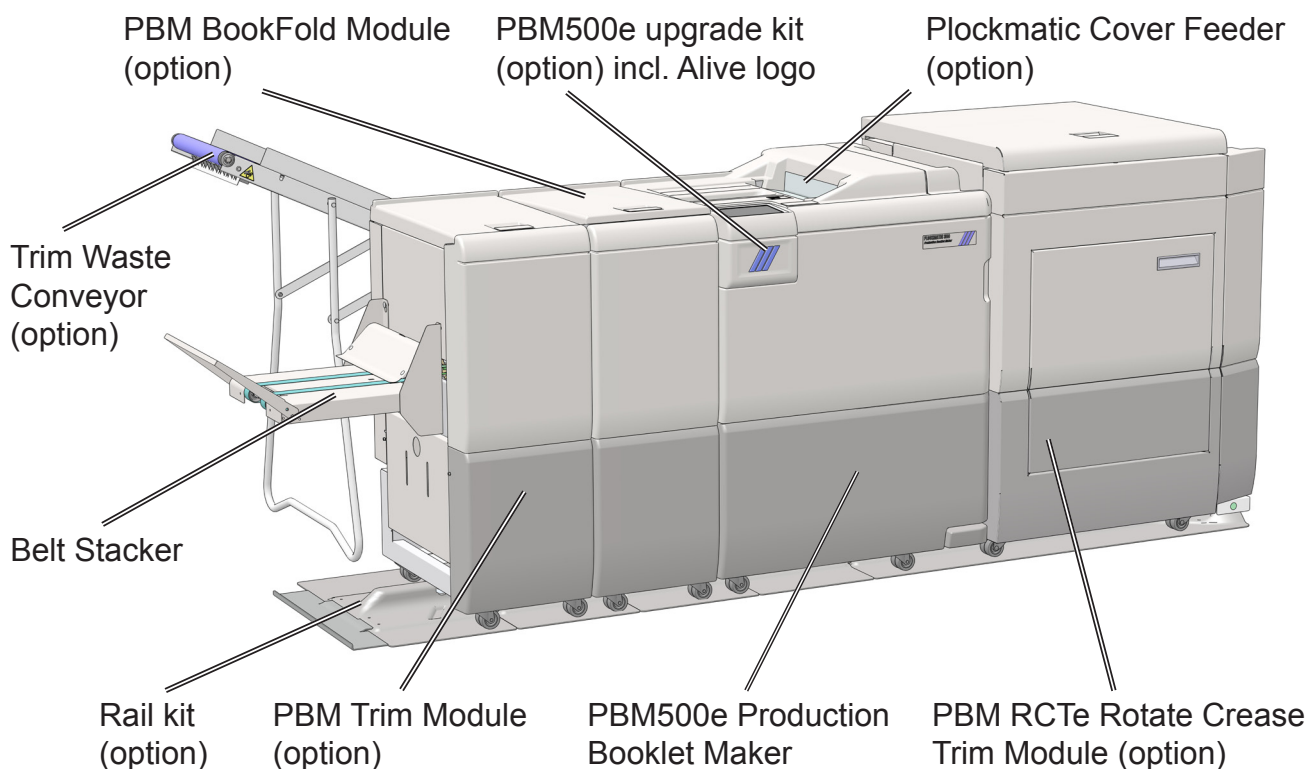

The Plockmatic 500e or the Plockmatic 350e Production Booklet Maker System consists of: **PBM RCTe Rotate Crease Trim Module 2.0** (optional), also referred to as the RCT Module, the RCT or the CT

PBM500e or PBM350e Booklet Maker, also referred to as the PBM500e/PBM350e or the Booklet Maker

Plockmatic Cover Feeder (optional), also referred to as the Cover Feeder

PBM BookFold Module (optional), also referred to as the BookFold Module or the BF

PBM Trim Module (optional), also referred to as the Trimmer Module or the Trimmer

Trim Waste Conveyor (optional), also referred to as the TWC

BST4000-1 Belt Stacker Module (optional), also referred to as the BST Module or the BST

Together they form a system that allows full bleed booklet making online with the Printer.

A capacity enhancement is the PBM500e upgrade kit. This kit increases the capacity of the PBM350e Booklet maker from 35 sheets to 50 sheets. This means that instead of 140 page booklets, 200 page booklets are now possible. The PBM500e upgrade kit also includes the Live logo feature. The logo below the user interface will be illuminated, allowing the user to monitor the system status from a distance.

The RCT Module is able to rotate small(er) sheets from long edge feed to short edge feed to maintain high printer productivity. In order to avoid toner cracking at the spine when folded, the RCT can be programmed to crease the cover sheet. The RCT can also trim the long sides of the booklet sheets to deliver booklets in the desired size.

To enable full bleed booklets, a PBM Trim Module must be installed after the Booklet Maker, see below.

continued on next page

From the RCT, the printed sheets are transported into the PBM500e or PBM350e Production Booklet Maker where they are compiled in the stapler area.

If a Plockmatic Cover Feeder is installed in the Booklet Maker, it can add any type of cover, in colour or black and white, to the printed set. The Booklet Maker jogs and staples the set. The set is then transported further into the Booklet Maker to the folding area where the set is folded into a booklet and delivered out to the belt stacker or a downstream model.

After the Booklet Maker, an optional PBM BookFold Module can be attached. The stapled and folded books will be fed into the BookFold Module where the spine of the booklets are flattened square. The booklets will now have the look of a perfect bound book. Finally, the booklets are fed out to the optional Trimmer or directly to a Belt Stacker.

When a larger number of sheets are folded, an effect called creeping occurs. In order to eliminate creep, an optional Trimmer Module can be attached after the Booklet Maker or BookFold Module. The booklets are transported from the Booklet Maker or BookFold Module into the Trimmer where the front edge will be cut off. The Trimmer combined with an RCT Module in front of the Booklet Maker creates the possibility to create full bleed booklets.

To allow longer, unattended runs there is an optional high capacity belt stacker available. The BST4000-1 Belt Stacker Module will stack up to 1000 A4 or 8,5 × 11” booklets of 4 pages.

In addition to producing booklets inline, it is possible to use the Booklet Maker System for hand-feeding.

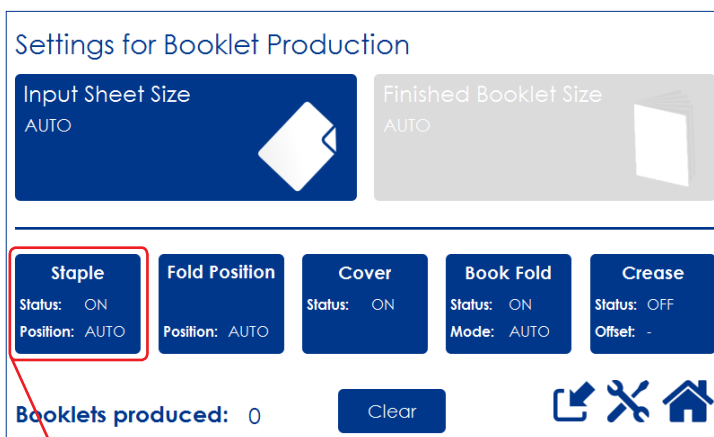

The user interface/control panel is of touch screen type. Point at the screen and press the button or function you wish to make changes to. In this sample screen shot, the Staple button is pressed.

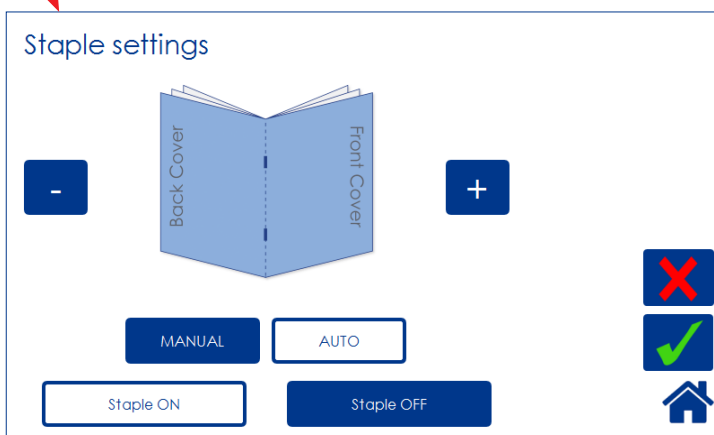

A sub screen is shown. Make your changes and confirm by pressing the green check mark or exit without making any changes by pressing the red X. Pressing the home symbol takes you back to the main or home screen.

Guide To Components

Booklet Maker

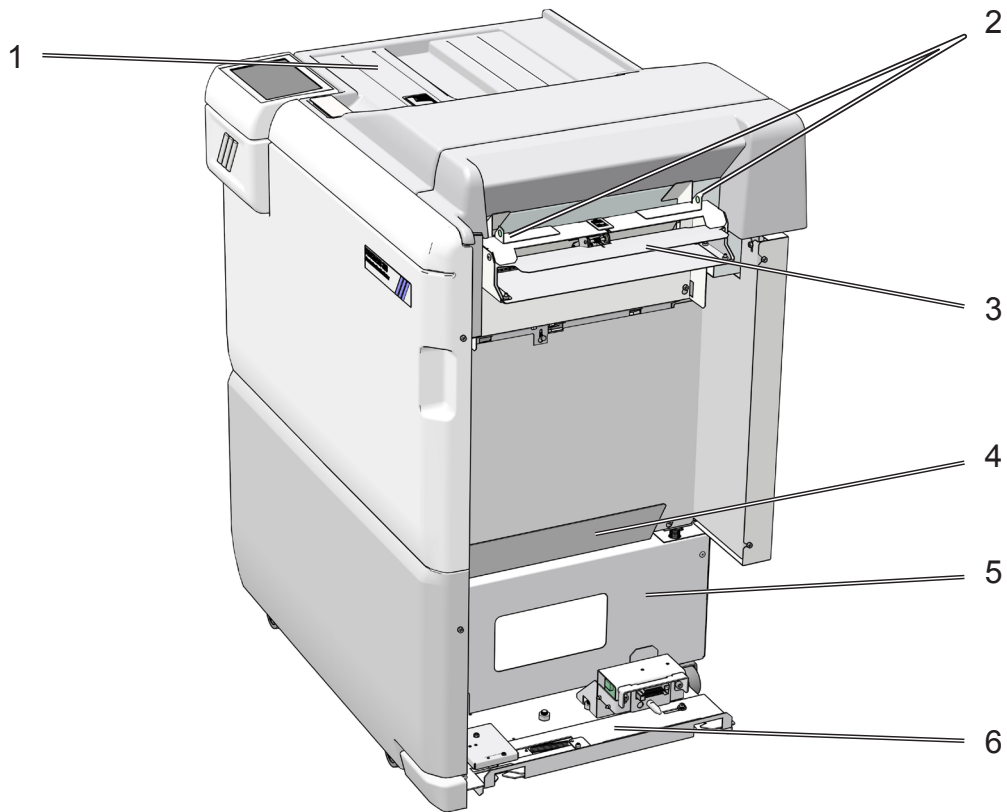

- | | | | |
|---|---------------------------|----|--|
| 1 | Top cover | 6 | Docking assembly |
| 2 | Hand feeding paper guides | 7 | Latch handle |
| 3 | Infeed assembly | 8 | Alive logo, only on PBM500e (optional) |
| 4 | Exit tray storing shelf | 9 | Belt Stacker |
| 5 | Base | 10 | Belt Stacker Cover |

Booklet Maker, continued

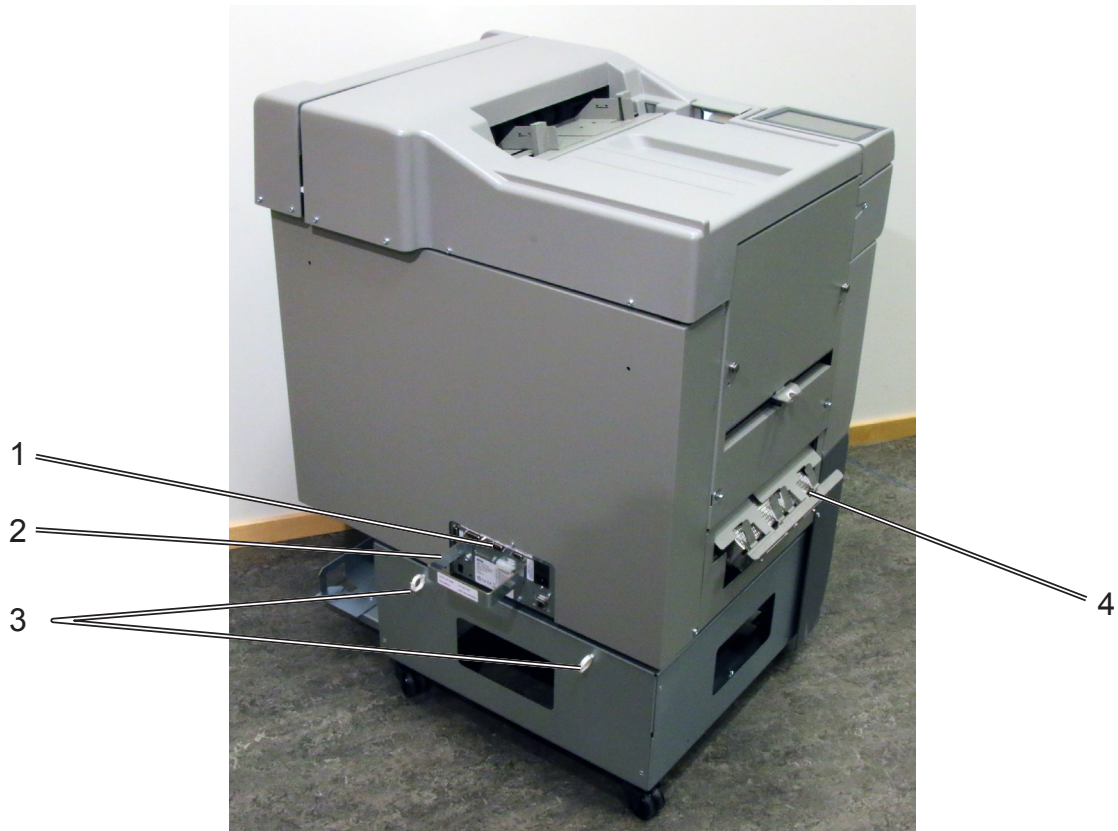

- 1 Connections
- 2 Cable protector
- 3 Cable holders
- 4 Fold stop gate



NOTE:

How to connect cables, plugs and jumpers is described at the end of this manual.

Booklet Maker, continued

Parts that are important for setup, adjustments, troubleshooting or maintenance are highlighted below.

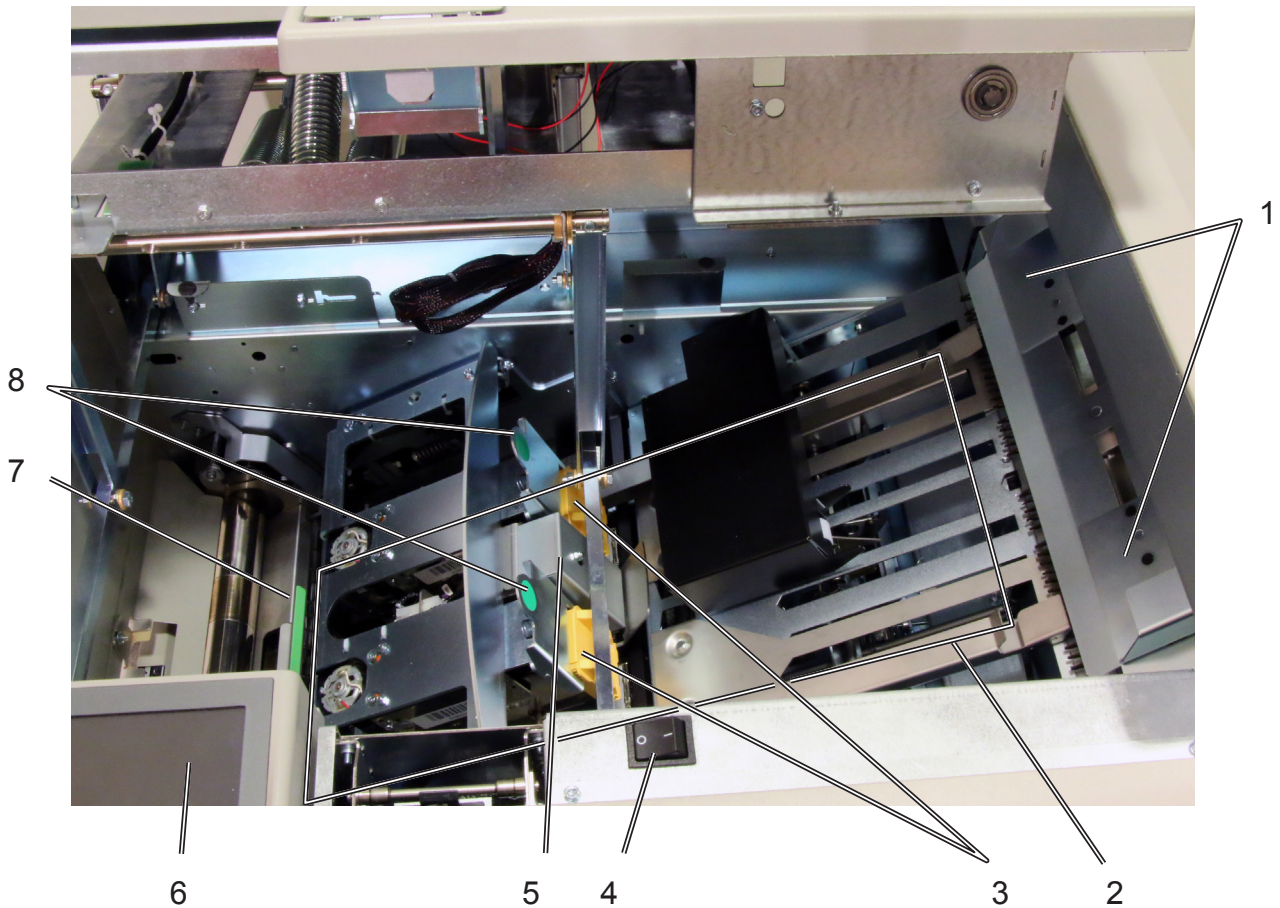

- 1 Hand feeding paper guides
- 2 Compiler area
- 3 Staple cartridges (incl. stapler heads)
- 4 Main power switch
- 5 Set thickness sensor
- 6 Control panel
- 7 Fold roller paper guide
- 8 Staple cartridge ejection lever

User Interface

The Plockmatic 500e or 350e Production Booklet Maker System is controlled from a panel located on the Booklet Maker. The control panel will allow you to set up, adjust and operate the complete system. An optional “Alive logo” makes the state of system visible from a distance.

 **NOTE:**

Depending on modules and features installed, the screen may look different from what you see here. Some functions are greyed out or not visible at all and remaining buttons may stretch to fit the screen. This manual will most often show a fully configured system.

Control Panel

The control panel is of touch screen type. Point at the screen and press the “button” to reach the desired function or change the desired setting.



The Start Screen

When the system power is switched on, the Start screen will be shown. From here you can choose to set up Booklet Production, perform a Guided Start, retrieve stored jobs or access the General System Settings.

If the Booklet Maker and/or the RCT is not docked, it will be shown here.

Settings for Booklet Production

Pressing the [Booklet Production] button in the Start Screen opens the Settings for Booklet Production screen. From here you can reach all detailed settings for setting up the job.

A counter shows the number of booklets produced. Clear will reset.

If the Booklet Maker and/or the RCT is not docked, it will be shown here.

Detailed Settings

Pressing, for example, the [Staple] button in the Settings for Booklet Production screen opens the Staple settings screen. Here you can perform detailed settings concerning stapling. Explore this and other settings more thoroughly in section 2, “Making Booklets.”

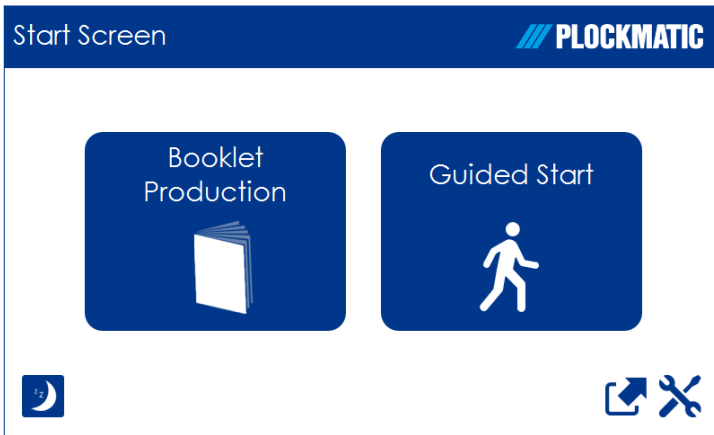

Guided Start

Guided Start is a function that takes you through all the basic settings the Booklet Maker System needs for booklet production in eight easy steps.

See “Guided Start” in section 2 “Making Booklets” for details.

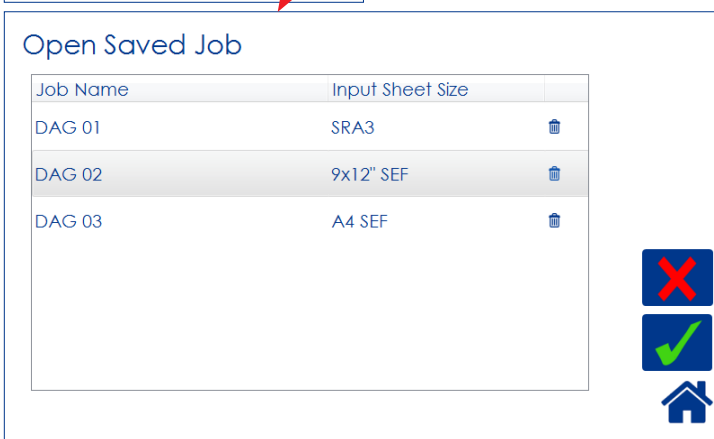
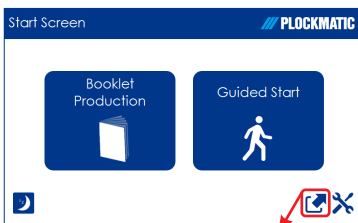

The Jobs Screen

Pressing the [Open Jobs] button in the Start screen opens the Open saved Job screen. From here you can open a saved job. Jobs can be stored, deleted, customized etc. Handling jobs is described in section 4, “Jobs”.

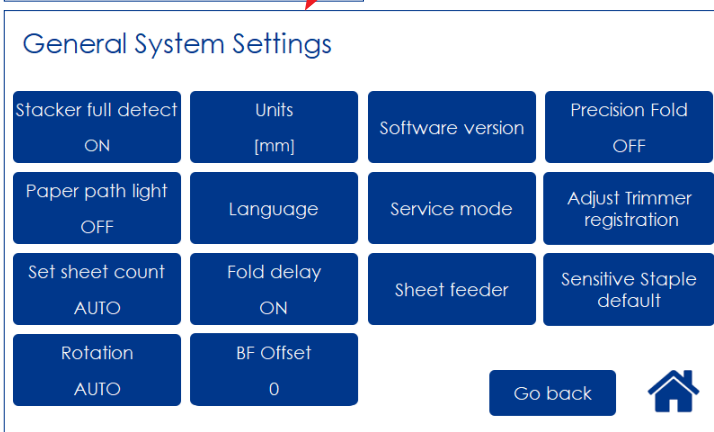
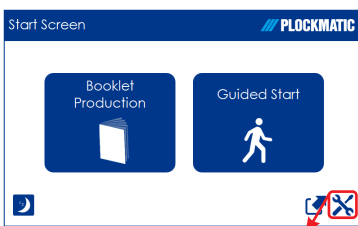

General System Settings

Pressing the [Tools] button opens the General Systems Settings screen. From here you can change basic settings like the display language, setting units from millimeters to inches and more. See section 3, “Tools”. for how to work with the Tools screen.

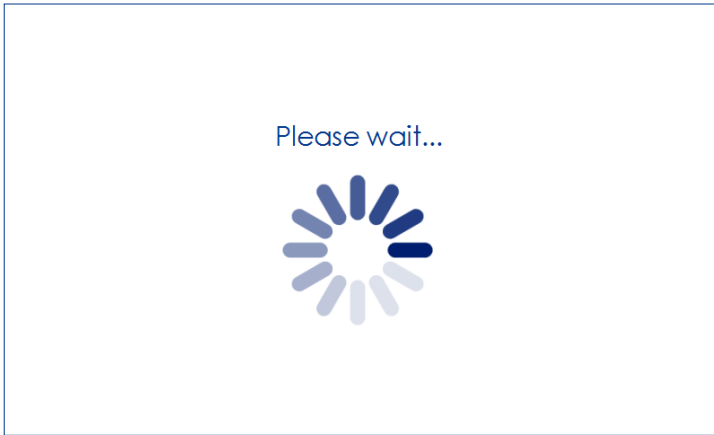

The Please wait screen

While the machine sometimes needs time to perform changes in settings, the Please wait screen will be shown.

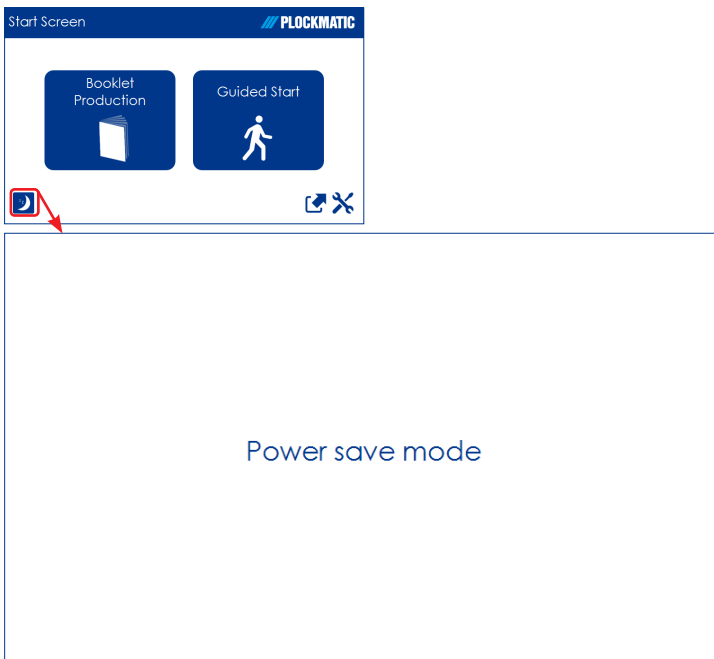

Power save mode

When the Booklet Maker System is in a ready state, it will enter power save mode after 20 minutes of inactivity.

To recover from Power save mode, touch the screen or send a print job to the Booklet Maker System.

The Booklet Maker System can also be forced into Power save mode by pressing the [Power save mode] button.

When the Booklet Maker system is processing or when there is a jam state it will not enter power save mode.

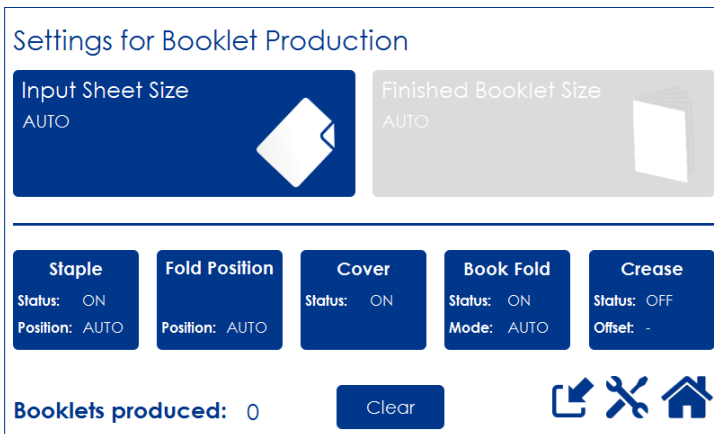

Information on screen

Depending on how the system is configured, the information on the screen changes and the size of the buttons will adapt to fit the screen.

This sample screen shows a fully configured Booklet Maker system with RCT, Cover Feeder, BookFold Module and Trimmer.

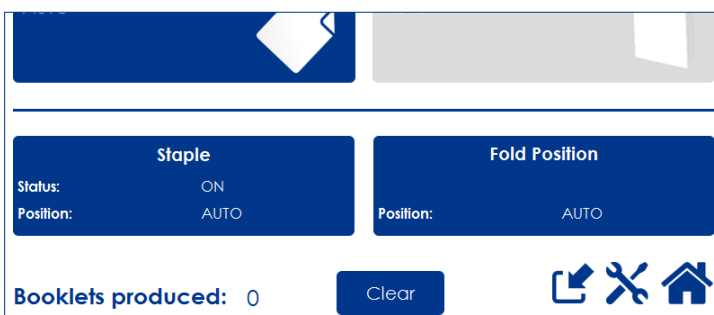

This sample screen shows exactly the same screen as above but this time the system is configured only with a Trimmer.

Options

Rotate Crease Trim Module

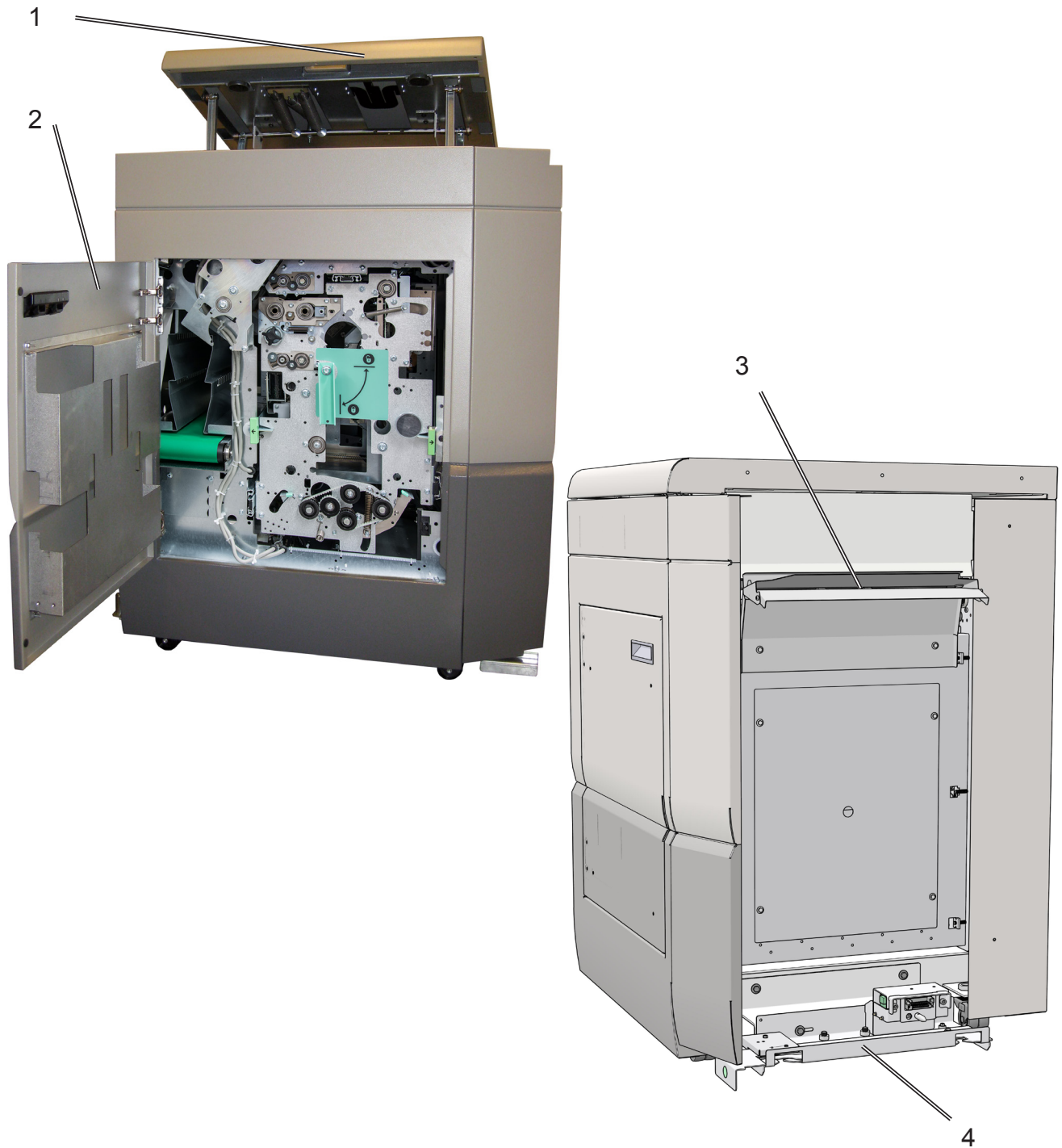

- 1 Top cover
- 2 Slide door
- 3 Infeed slot
- 4 Upstream docking assembly

Rotate Crease Trim Module, continued

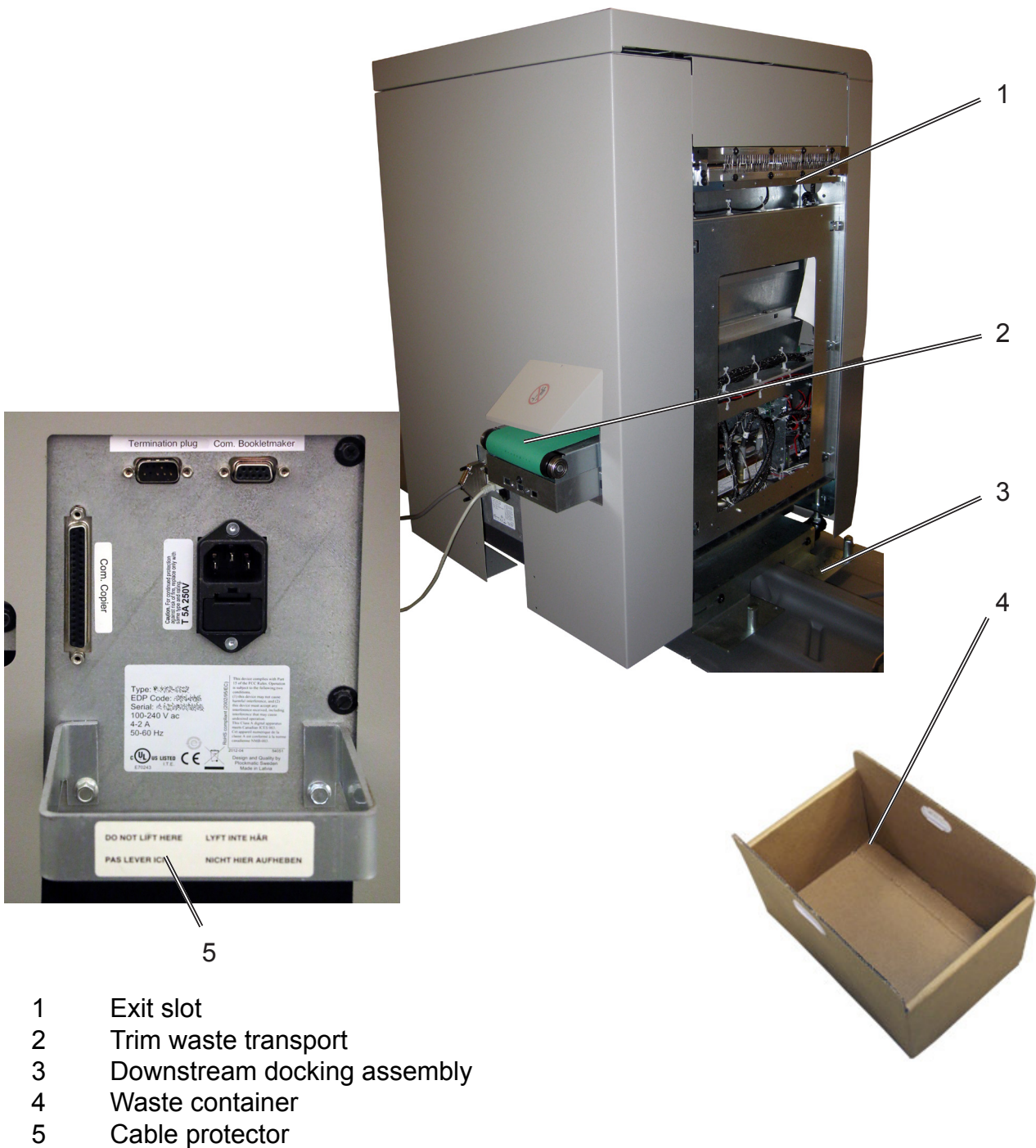

 **NOTE**

How to connect cables, plugs and jumpers is described at the end of this manual.

Rotate Crease Trim Module, continued

Parts that are important for setup, adjustments, troubleshooting or maintenance are highlighted below.

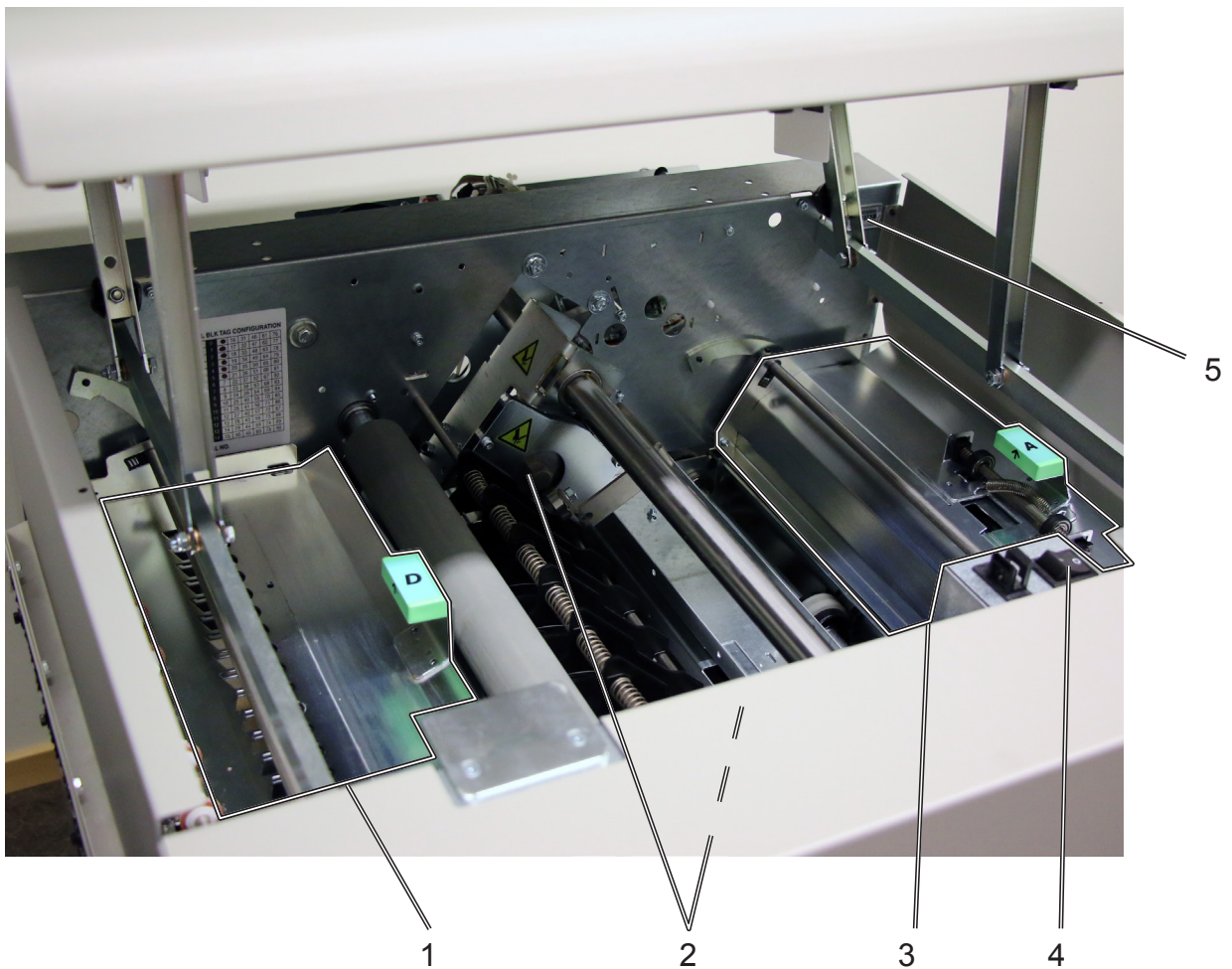

- 1 Exit section "D"
- 2 Bleed trimmer circular knives
- 3 Infeed Section "A"
- 4 Main switch
- 5 Counter

Rotate Crease Trim Module, continued

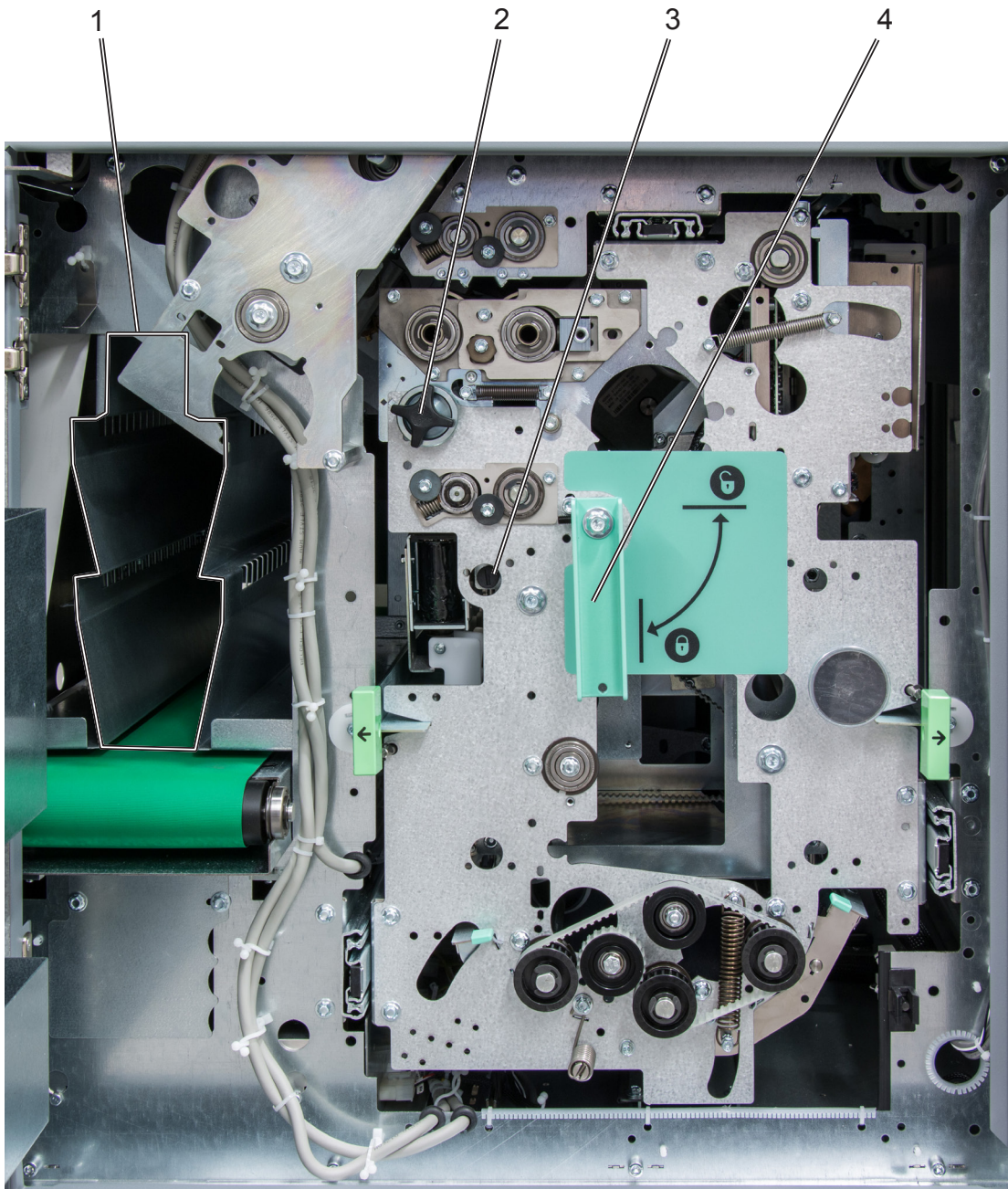

- 1 Waste chute(s)
- 2 Creaser registration adjustment
- 3 Bleed trimmer registration adjustment
- 4 Latch handle, slide

Rotate Crease Trim Module, continued

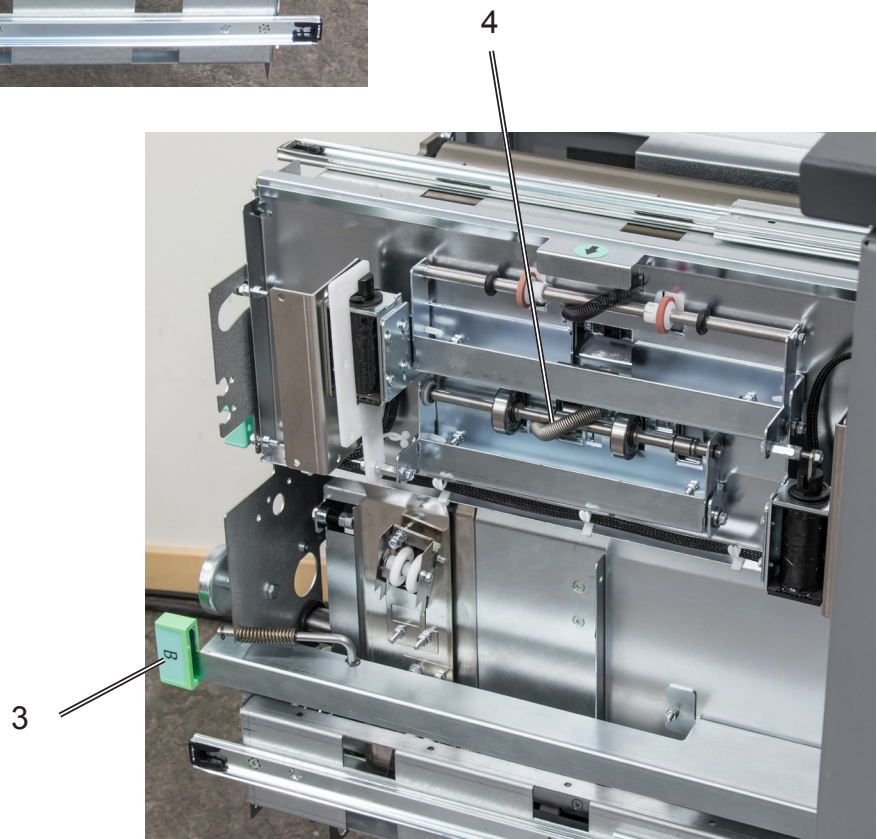
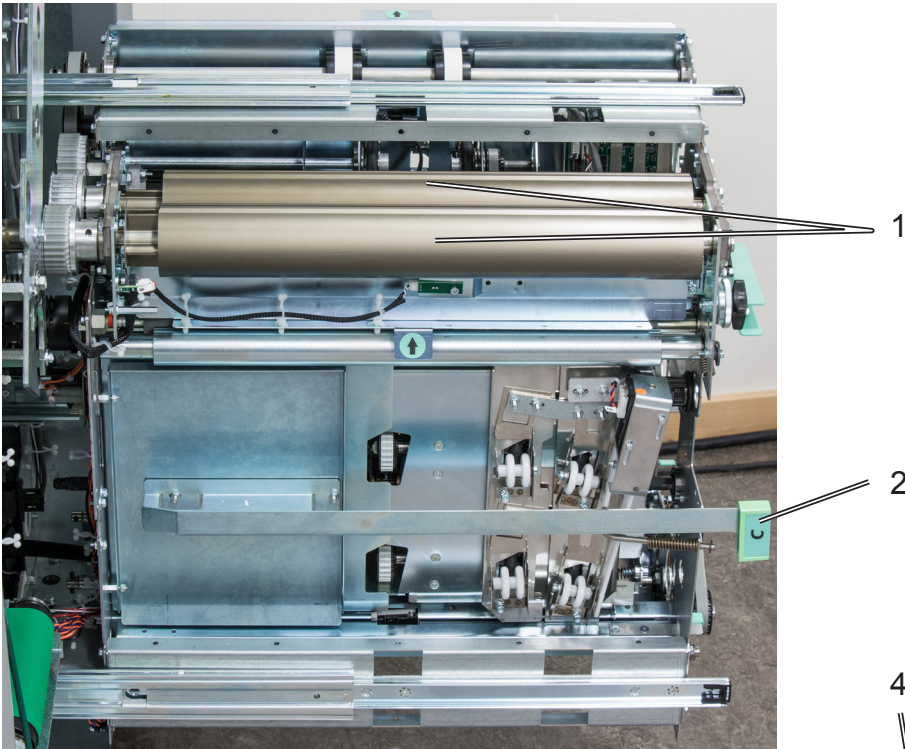

- 1 Creaser tools
- 2 Jam clearance baffle, fine registration, section "C"
- 3 Jam clearance baffle, coarse registration, section "B"
- 4 Rotator

Booklet Maker

Alive logo



Alive logo

With a PBM500e upgrade kit installed, the three stripes below the user interface will signal status as follows:

Not illuminated - System in power save mode or switched off.

Steady blue - System is on and ready.

Blue stripes add one at a time, faster - System is preparing to run.

Blue stripes add one at a time, slower - System is running.

Alternating blue/yellow - Soft stop (staples low, cover low, stacker full, waste bin full).

Alternating blue/red - Jam or malfunction

Booklet Maker, continued

Cover Feeder

Parts that are important for setup, adjustments, troubleshooting or maintenance are highlighted below.

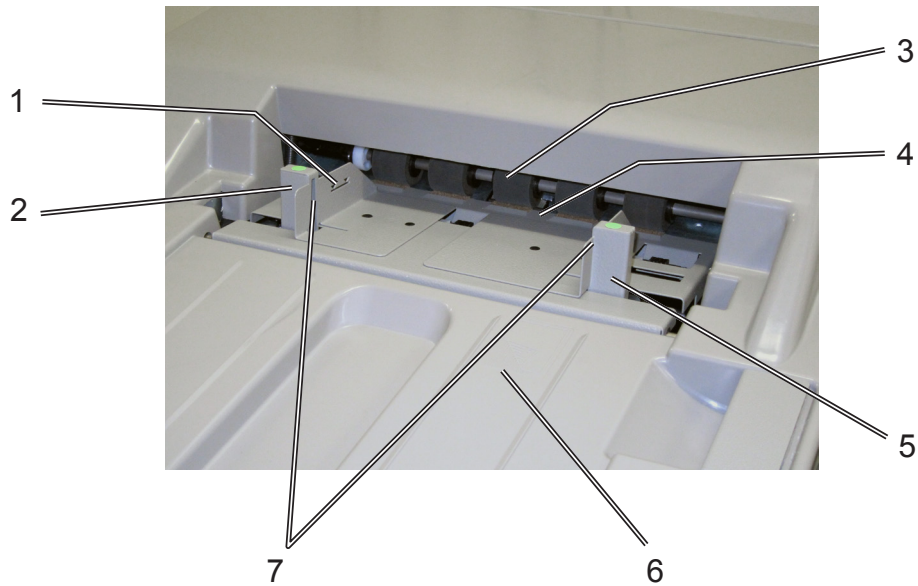

- | | | | |
|---|-----------------------|---|-----------------------------|
| 1 | Loading capacity mark | 5 | Front side guide |
| 2 | Rear side guide | 6 | Paper orientation indicator |
| 3 | Feed roller assembly | 7 | Air nozzle (2x) |
| 4 | Paper separator pad | 8 | Jam clearance baffle |

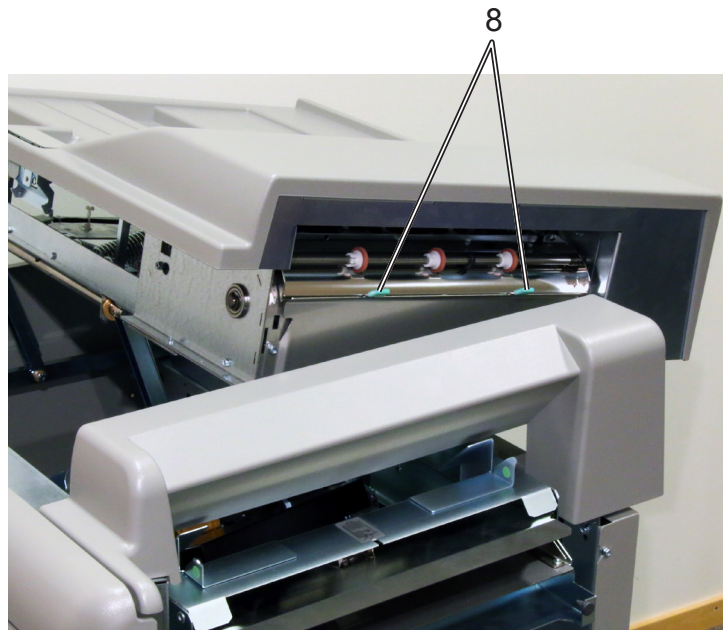

BookFold Module



- 1 Top cover
- 2 Trim bin location
- 3 Base

- 4 Connections
- 5 Cable protector

 **NOTE:**
How to connect cables, plugs and jumpers is described at the end of this manual.

BookFold Module, continued

Parts that are important for setup, adjustments, troubleshooting or maintenance are highlighted below.

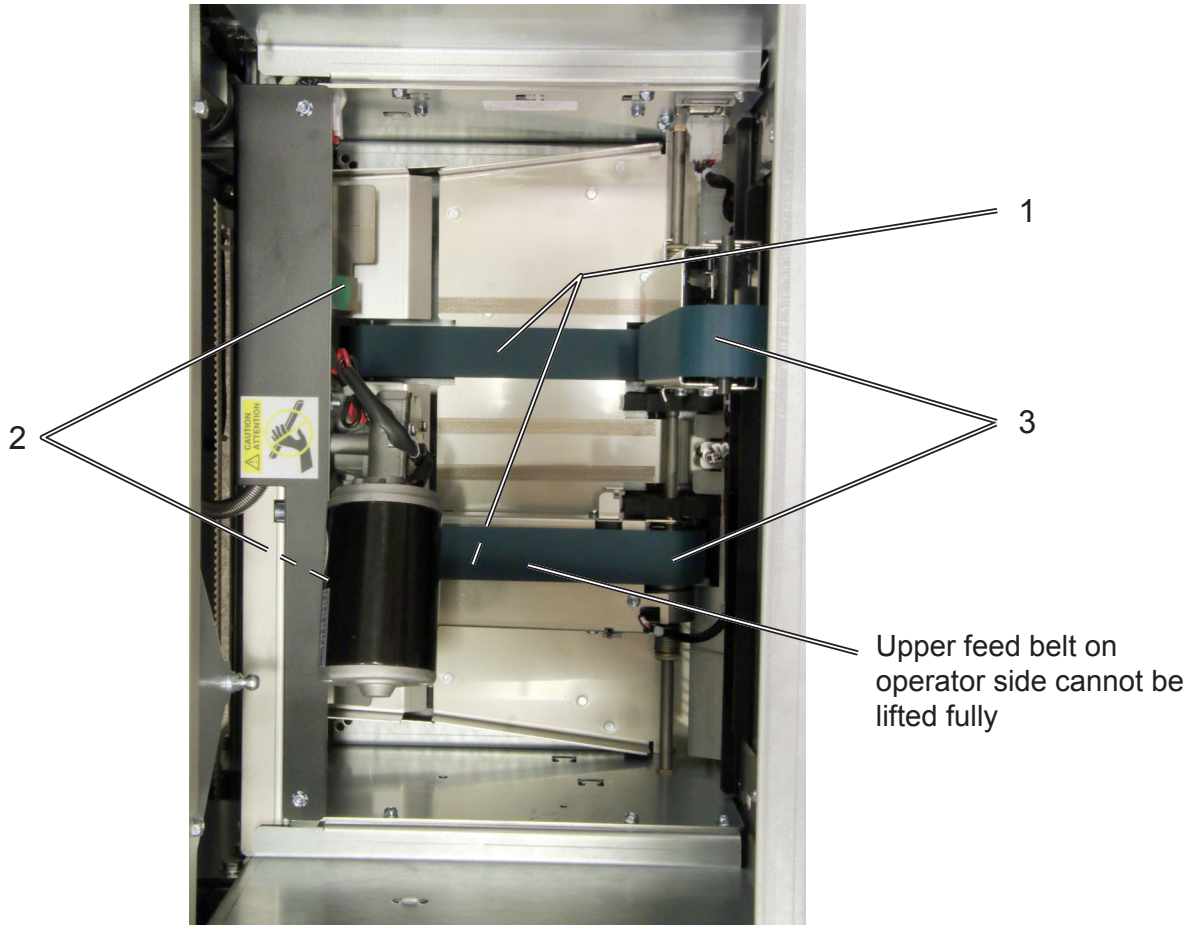

*BookFold Module, top view,
non operator side upper feed
belts lifted up*

- 1 Lower feed belts
- 2 Upper feed belt release latch
- 3 Upper feed belts

Trimmer



- 1 Top cover
- 2 Trim bin
- 3 Base
- 4 Connections
- 5 Cable protector

 **NOTE:**
How to connect cables, plugs and jumpers is described at the end of this manual.

Trimmer, continued

Parts that are important for setup, adjustments, troubleshooting or maintenance are highlighted below.

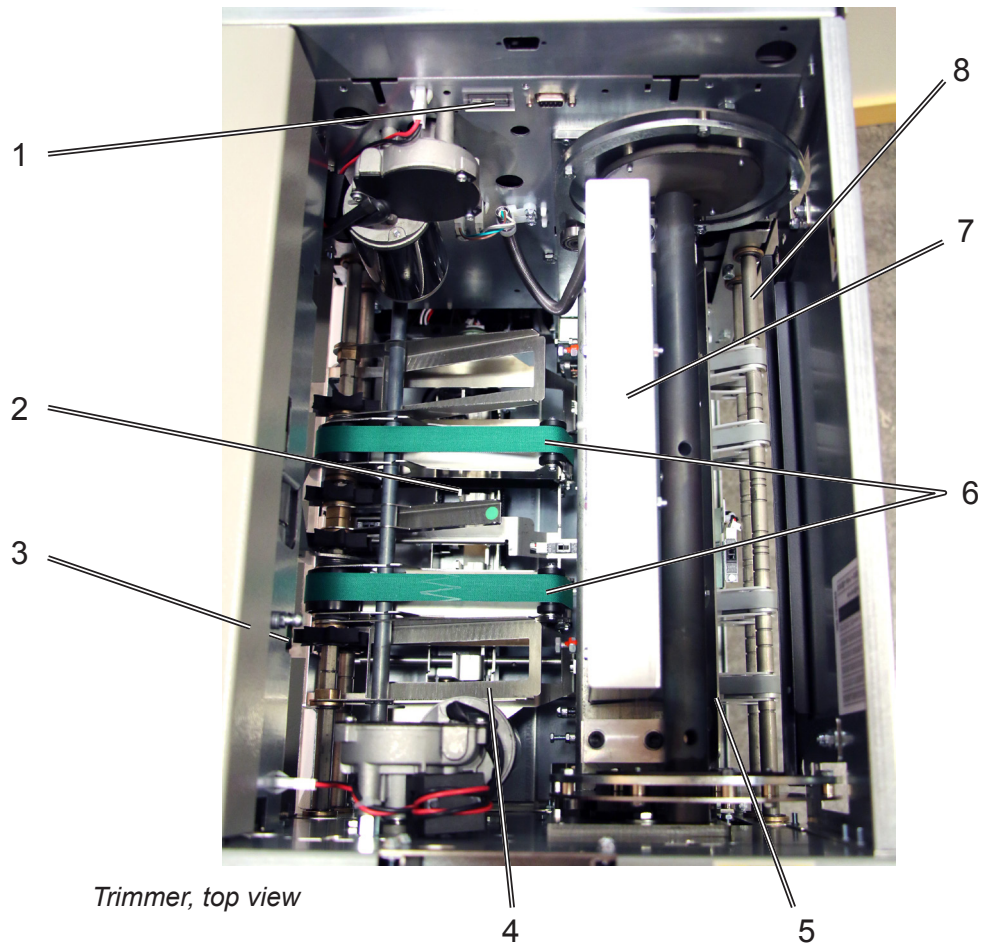

Trimmer, top view

- | | | | |
|---|---------------------------|---|---------------------|
| 1 | Set counter | 5 | Upper knife |
| 2 | Trimmer stop | 6 | Transport belt |
| 3 | Exit drive release | 7 | Trimmer fan |
| 4 | Exit compressing brackets | 8 | Infeed roller shaft |

BST4000-1 Belt Stacker Module

The BST4000-1 High Capacity Belt Stacker Module is an option available for the Plockmatic 500e or 350e Production Booklet Maker System. The stacker can be configured in a straight line after the booklet maker system or at a 90 degree angle.

Parts that are important for setup, adjustments, troubleshooting or maintenance are highlighted below.

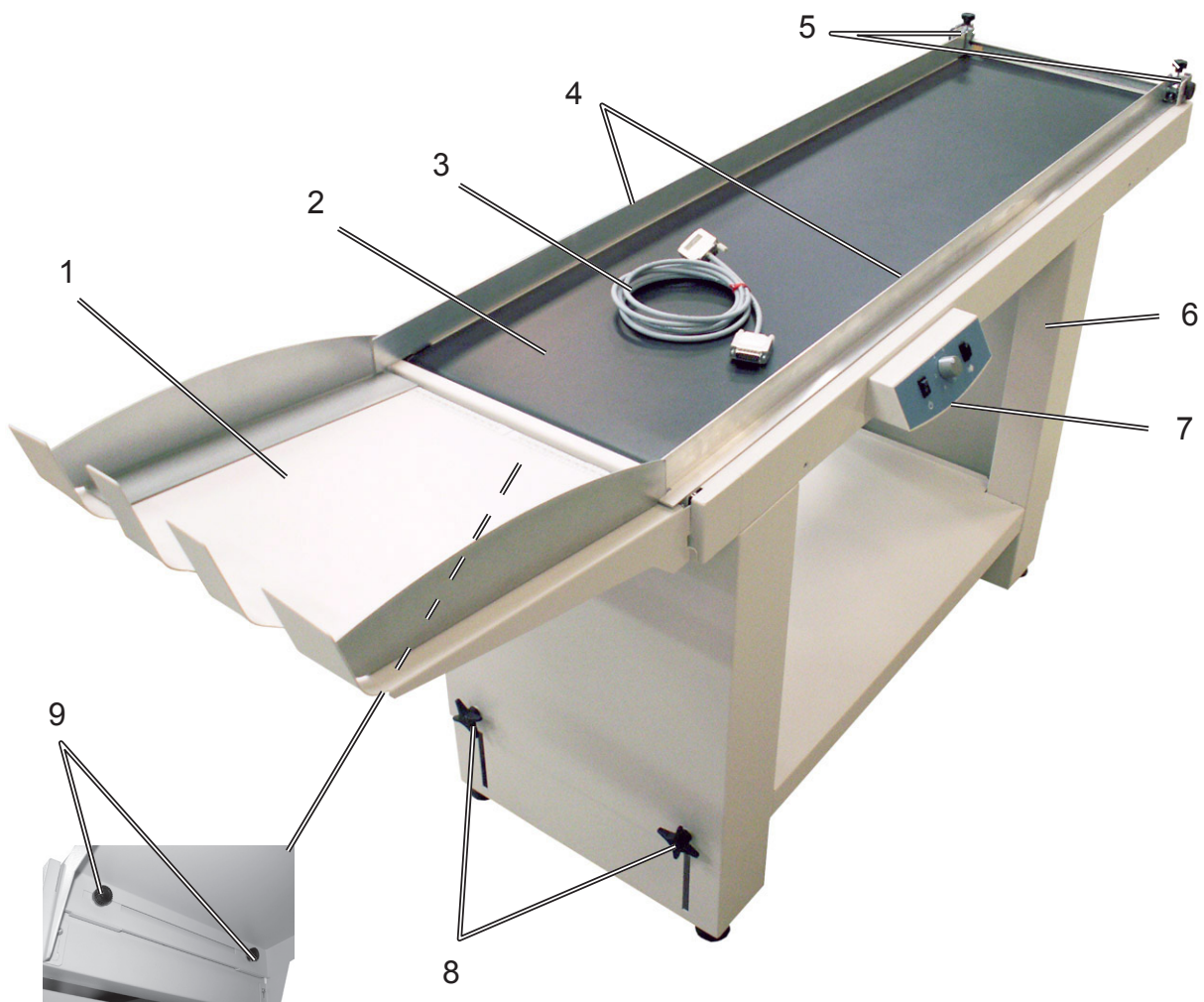

- 1 Stacking tray
- 2 Conveyor belt
- 3 COM-cable
- 4 Side guides
- 5 Front end side guide adjustment knobs
- 6 Leg assembly
- 7 Control panel box
- 8 Height adjustment knobs (two on each leg)
- 9 Rear end side guide adjustment knobs (underneath)

BST4000-1 Belt Stacker Module, continued

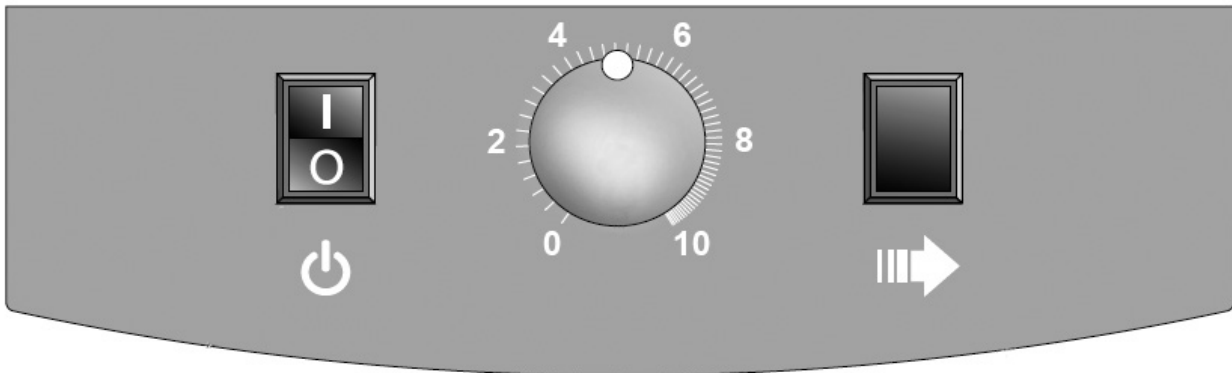

(1)

(2)

(3)

- 1 Power switch (on/off)
- 2 Belt speed selector
- 3 Run-out button (full speed)

BST4000-1 Principle of Operation

The belt is triggered by a signal from the Booklet Maker and will run for a set time.

The belt speed can be adjusted in order to optimize the stacking function for various materials.

The Run-out button is used to gather the material after a job is finished. The belt then moves at the highest speed, independent of the speed setting.

The power switch is also used to reset the unit after an overload situation.

Trim Waste Conveyor

Parts that are important for setup, adjustments, troubleshooting or maintenance are highlighted below.

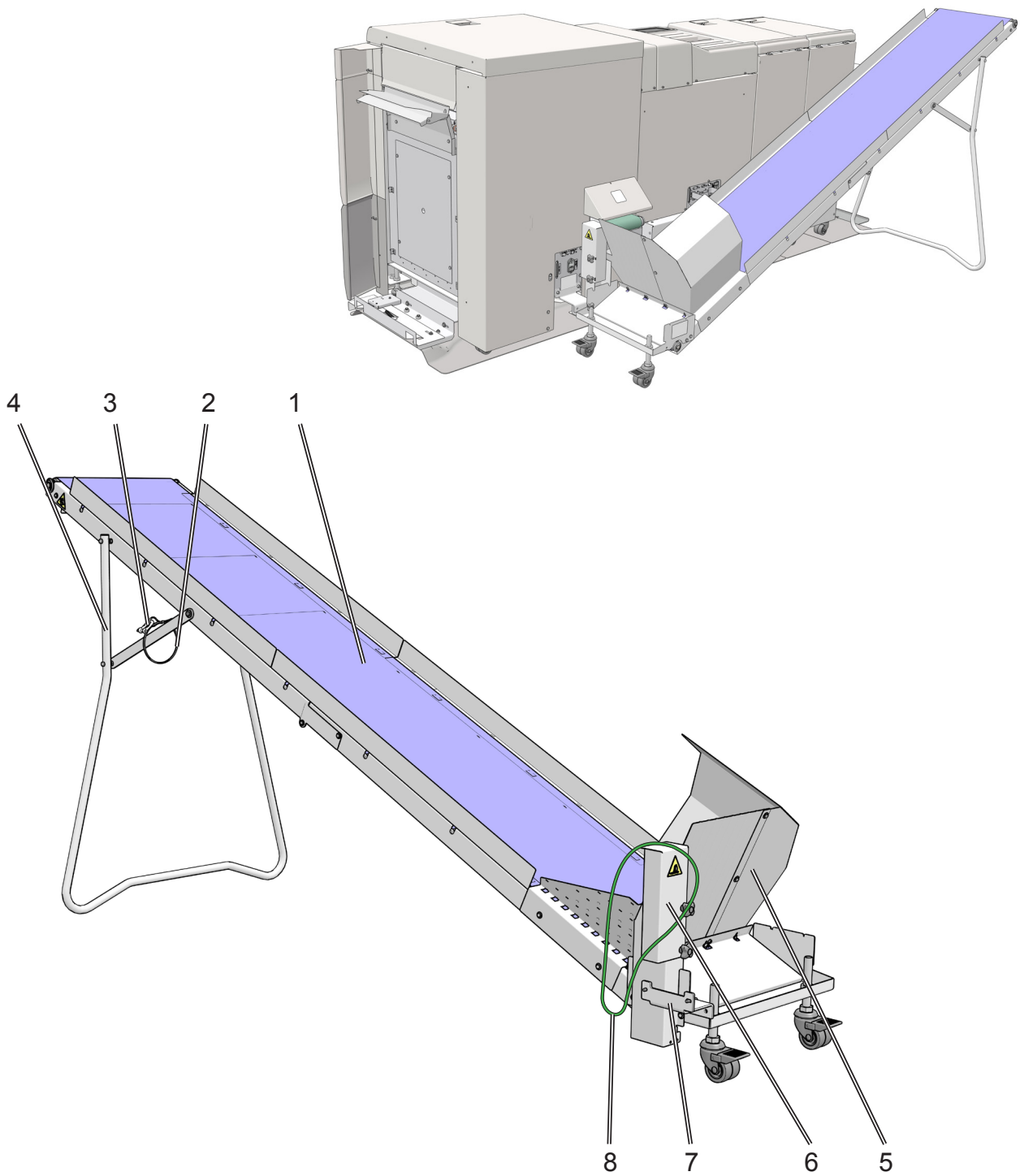

- 1 Conveyor belt
- 2 Safety wire
- 3 Shackle
- 4 Support

- 5 Tray
- 6 Cable protection extension
- 7 Docking bracket
- 8 O-ring (drive belt)

1. Basics

Turning On / Off the Main Power

RCT, Booklet Maker, BookFold Module, Trimmer & BST Module

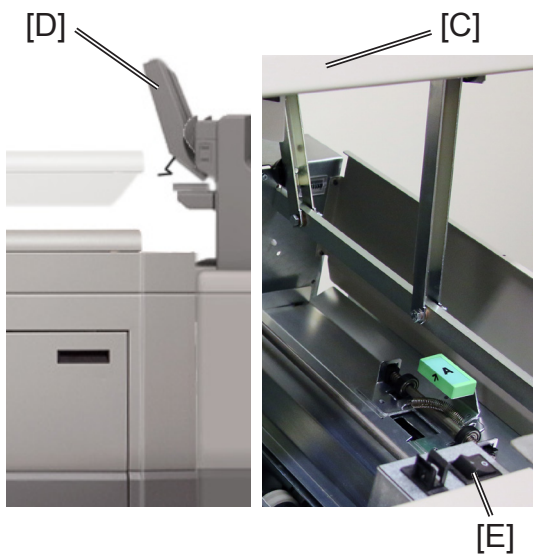
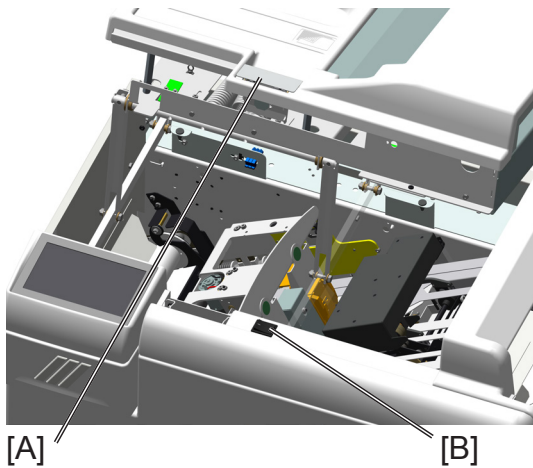

- 1 Make sure that the Booklet Maker, RCT module (optional) and BST power cords are plugged into the wall outlet.



NOTE:

BookFold (optional) and/or Trim (optional) Modules are both powered from the Booklet Maker.

- 2 Open the Booklet Maker top cover [A].
- 3 Set main power switch [B] on Booklet Maker to ON position. If a BookFold Module and Trimmer are attached, they will be powered on via the Booklet Maker main power switch.
- 4 Close the Booklet Maker top cover.
- 5 Open the top cover of the RCT [C].
⚠ CAUTION
To avoid the Upper Shift Tray from obstructing the RCT Top Cover, make sure the upper Shift Tray is in the upright position [D]. See Docking/Undocking below.
- 6 Set the main power switch [E] to ON position.
- 7 Close the RCT top cover.

- 8 Set main power switch [F] on the BST Module to ON position.

Change staple cartridges and Check stapler

The staple cartridges contains approximately 5000 staples each. Each cartridge includes all wearable parts. The cartridges may need to be removed either for replacement or for jam clearance.

1

Change left/right staple cartridge(s)

Attention!

Area B2: Replace right and left staple cartridges!

Turn staple off

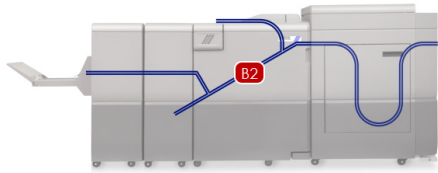

The Booklet Maker will indicate “Change left/right/left and right staple cartridges” when there are approximately 20 staples left in the stapler cartridge. Replace the indicated staple cartridge by doing the following:

- 1 Open the Booklet Maker top cover.
- 2 Press the staple cartridge ejector lever (A) and pull out the staple cartridge (B) using the grip (C) at both sides at the top of the staple cartridge.
- 3 Replace by pushing a new staple cartridge into stapler until it snaps into position.
- 4 Close booklet maker top cover and restart the job.

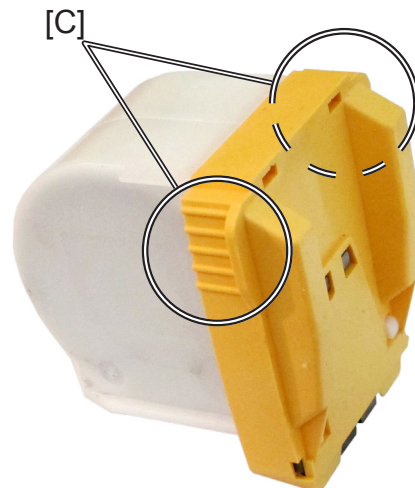
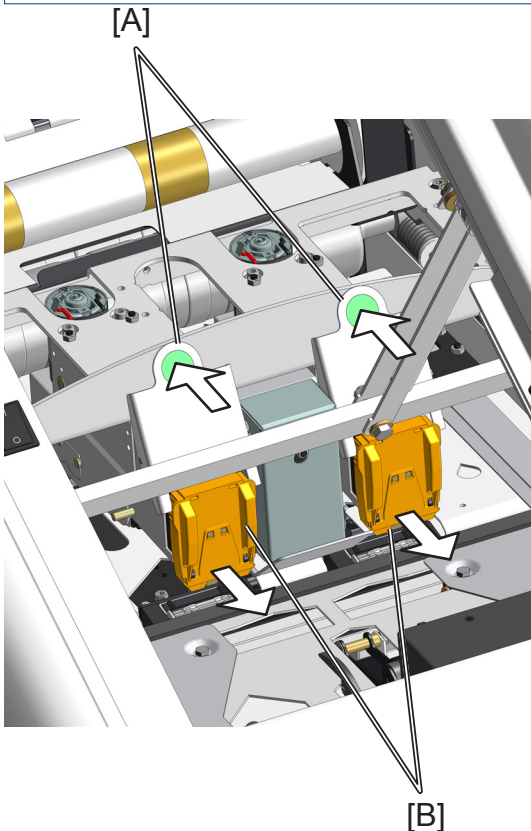

Check left/right stapler

Attention!

Area B2: BK-402, Check left stapler!

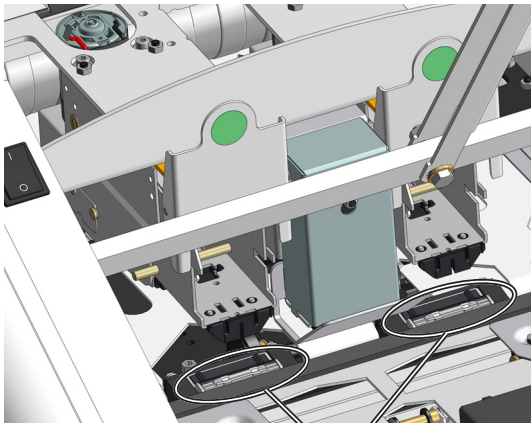
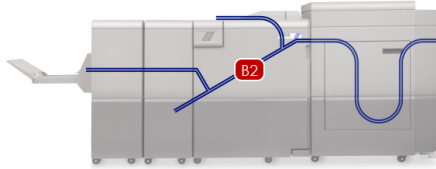

[A]

If the Booklet Maker indicates “Check right/left/right and left stapler”, it means that there is a jam in the indicated stapler. Remove the stapler cartridge as described above.

- 1 Open the Booklet Maker top cover.
- 2 Press the staple cartridge ejector lever and pull out the staple cartridge as described above.
- 3 Remove any sheets left in the Booklet Maker and look for jammed staples stuck in the sheets.
- 4 Look inside the staple cartridge for jammed staples and remove them if any.
- 5 Look at the clinchers [A] and remove any jammed staples.
- 6 Push the staple cartridge into stapler until it snaps into position.
- 7 Close Booklet Maker top cover and restart job.

 **NOTE:**

If the error message persists for no reason or if staple jam reoccurs, replace the staple cartridge as described above.

Loading Covers into the Cover Feeder

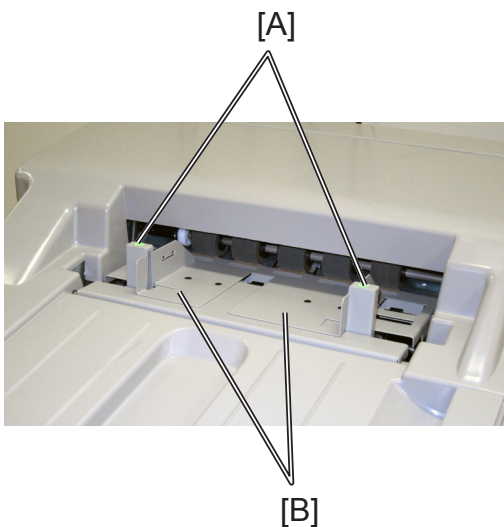

- 1 Make sure the cover sheets are well fanned to avoid misfeeds or double-feeds.
- 2 Align the cover sheets well to achieve a reliable feeding operation and good finishing results.
- 3 Make sure that the ink has completely dried, to avoid smearing.
- 4 Press on top of either air nozzle [A] to lower the paper bin. Load the covers facing downwards into the paper bin.
- 5 Adjust side guides [B] up against the cover sheets until there is no clearance.

 **NOTE:**

Make sure covers are same size as sheets fed to booklet maker. When using an RCT, see Note under “Changing settings, Finished Booklet Size, Custom booklet size”.

Emptying the trim waste bin

Remove the trim waste bin by lifting it and pulling it out.

1

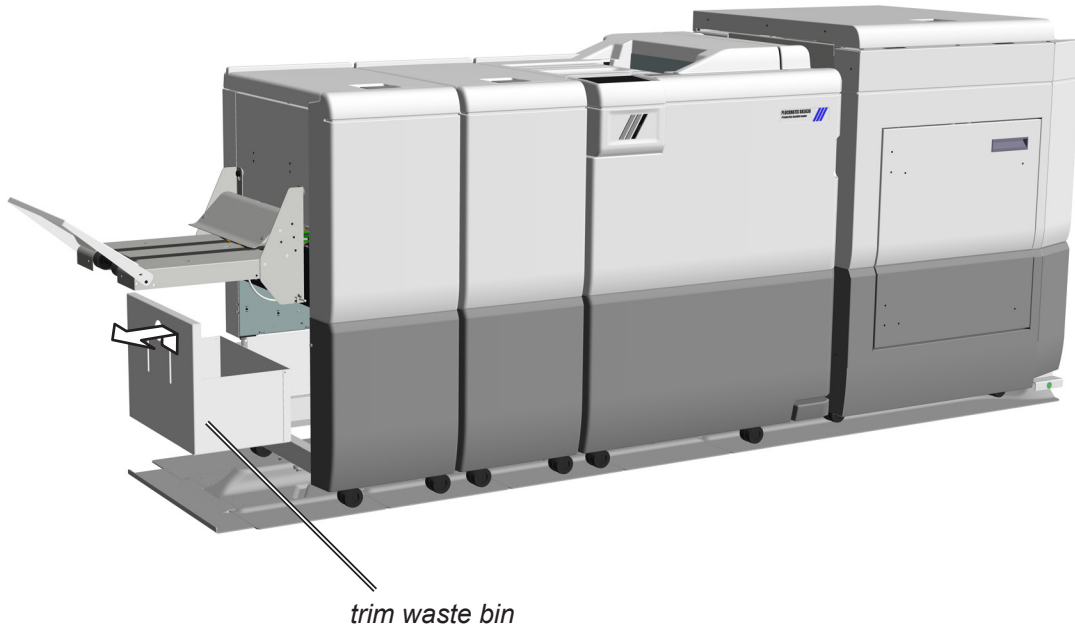

Removing trim waste from trimmer blade area

The purpose of the Trim waste guides [A] is to guide waste material towards the waste chutes. The Trim waste guides are fastened using magnets and can be moved aside or removed completely, should waste material get caught in the trimmer blade area.

⚠ WARNING:

Do not put your fingers within knife protections [B]. Doing so may result in injury.

⚠ CAUTION:

Under no circumstances should jams around the trimmer blades be cleared using metallic tools. The edges are very fragile and easily damaged.

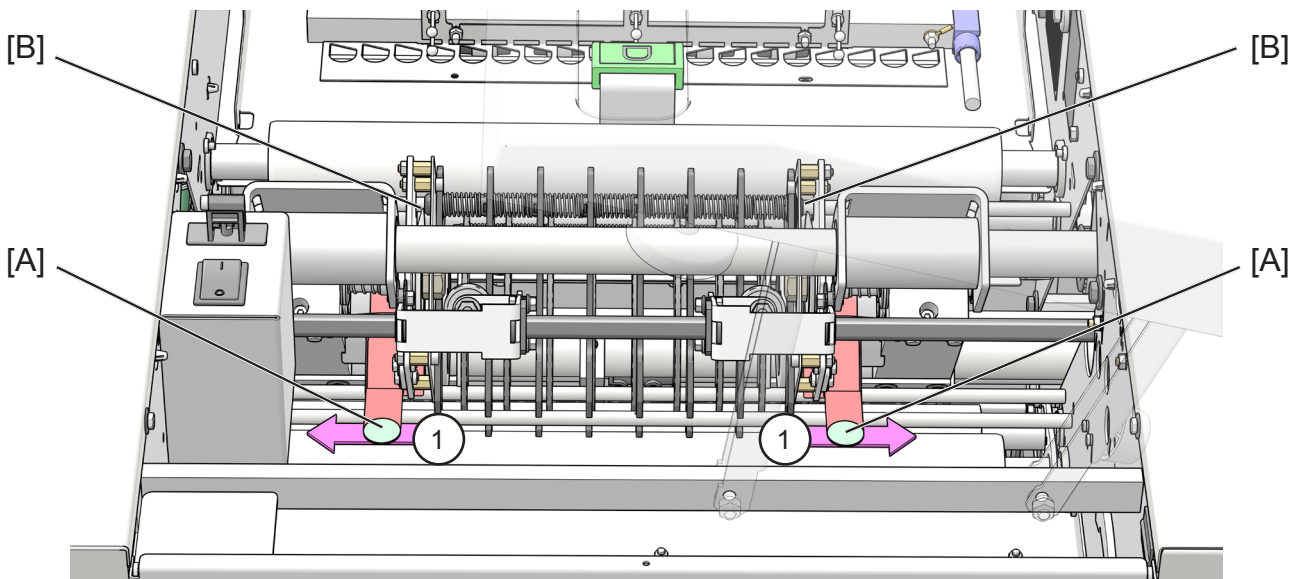

Top cover of the RCT made transparent for clarity

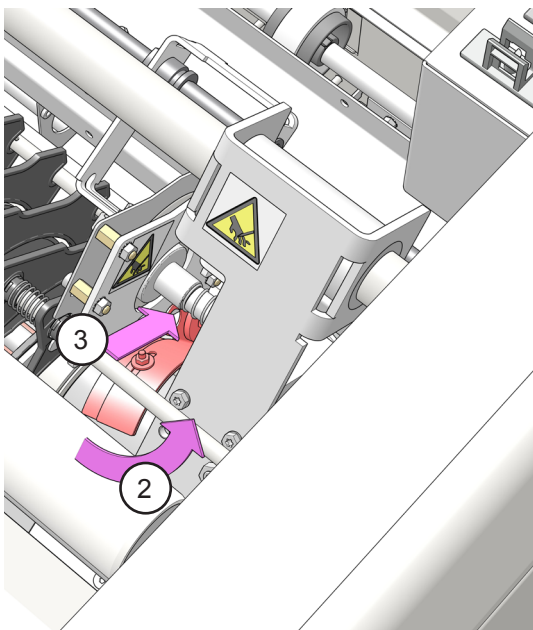

- 1** Set the Paper Size to A3 or 11x17". See section 2, "Selecting standard paper sizes".
- 2** Set the Width of the Custom Booklet Size to minimum value (max trimming). See section 2, "Custom Booklet Size".
- 3** Open the RCT top cover.
- 4** Move the Trim waste guides aside (1) to access and remove waste material gotten caught.
- 5** For more access, remove the Trim waste guides completely by twisting (2) and wiggling while pulling (3) it towards the infeed area. Illustration shows the operator side. On the non operator side, twist the Trim waste guide clockwise before wiggling it while pulling it towards the infeed area.
- 6** After removing waste material, reinstall the Waste material guides to normal position
- 7** Close the RCT top cover.

Setting up the Belt Stacker

Right-angled mode

1

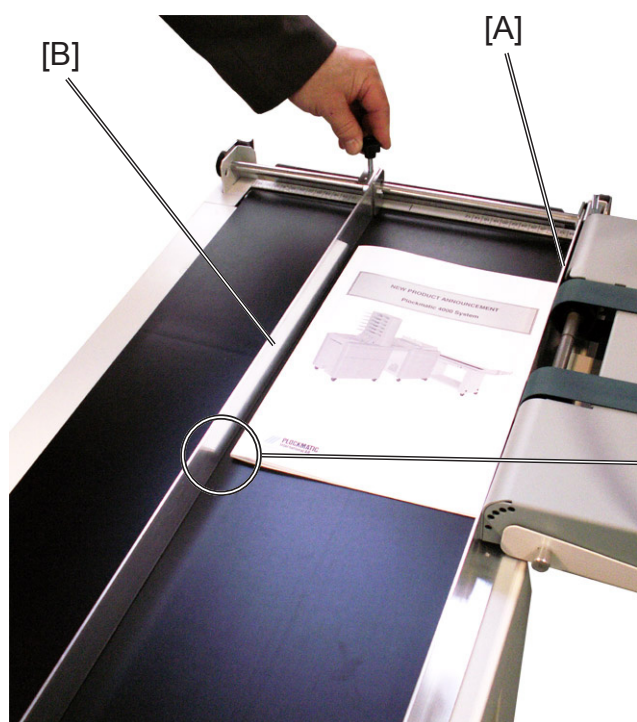

- 1** Move the inner Side Guide [A] as far as possible towards the Booklet Maker.
- 2** Adjust the outer Side Guide [B] to give at least 5mm (1/4") play. Tighten the Side Guides at both ends.

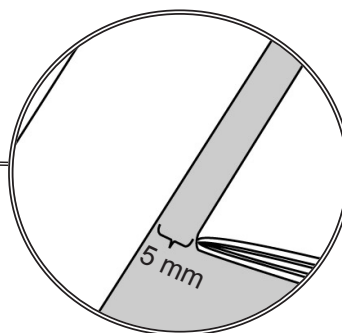

- 3** Adjust the stacking with belt speed selector.

Setting up the Belt Stacker, continued

Straight mode

1



- 1** Adjust Side Guides to their outermost position by loosening knobs [A].
- 2** Adjust the stacking with belt speed selector [B].

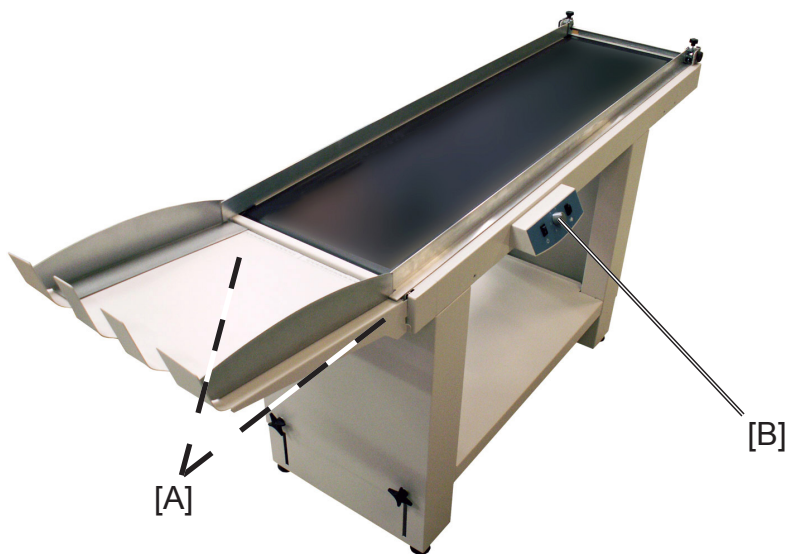

Detaching / Attaching the Trim Waste Conveyor

Detaching the Trim Waste Conveyor

1

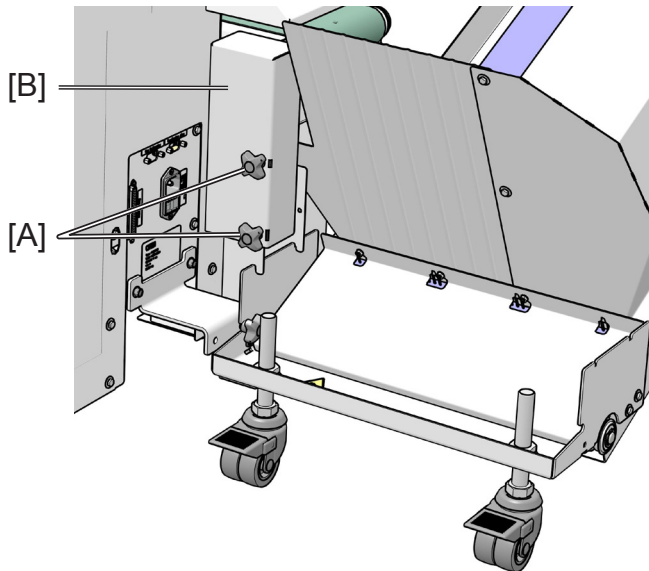

- 1** Loosen the Knobs [A] (x2) and remove the Cable Protection Extension [B].

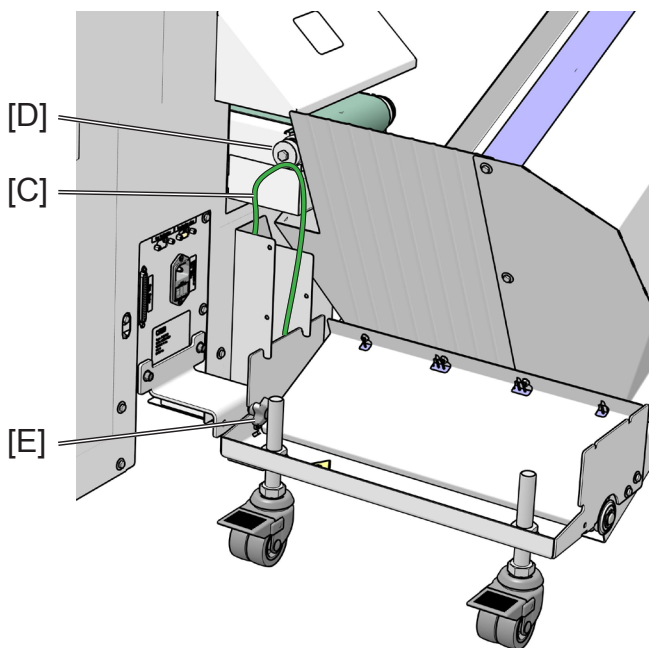

- 2** Unhook the O-ring [C] from the upper Pulley [D]
- 3** Loosen Knob [E]. The TWC is now detached from the RCT and can be moved away.

Attaching the Trim Waste Conveyor

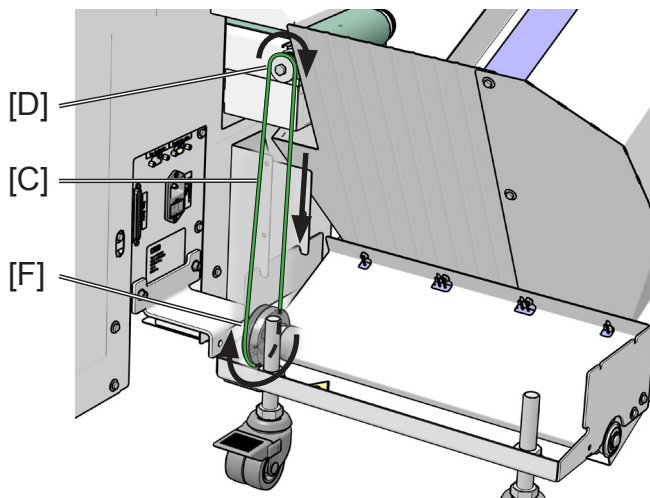

1 Attaching the Trim Waste Conveyor is an exact reversal of detaching as described above.

NOTE:
In order to make the conveyor belt travel in the correct direction, make sure to route the O-ring [C] on the Pulleys [D] and [F] as illustrated.

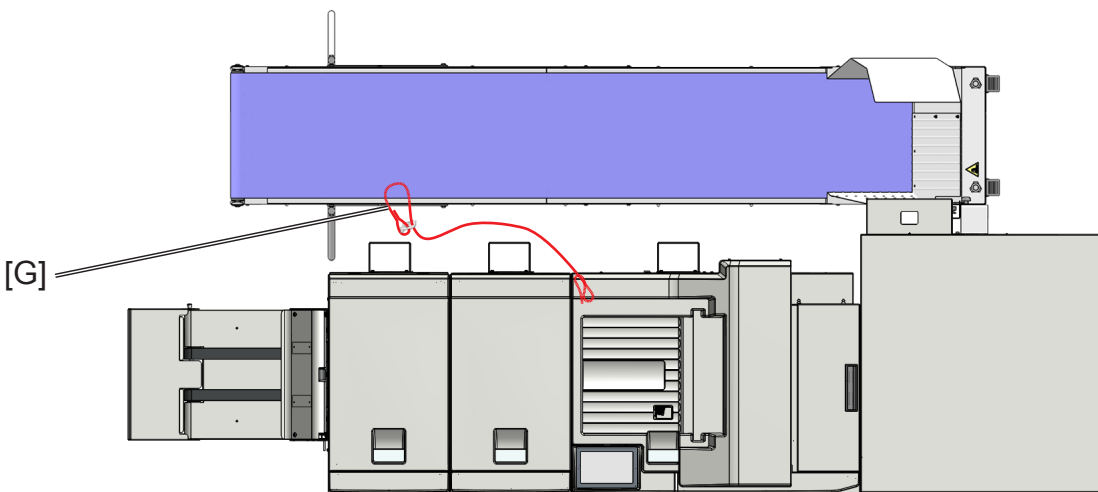

2

Ensure that the Trim Waste Conveyor is parallel to the Booklet Making System.

⚠ WARNING

To prevent the Trim Waste Conveyor from falling over, a safety wire [G] must be installed between the Conveyor support and the height adjustment between the Booklet Maker on the exit side and the base.

Reinstall the Safety Wire [G] if it earlier was removed.

Docking / Undocking the Booklet Making system

Docking

1

1 Turn the Printer off.

2 Lift up the Exit arm catcher on the Printer Finisher and set the Exit paper arm in the upper position.

3 Remove the Exit tray from the Printer's Finisher and put it on the shelf on the Booklet Maker.

4 Move the Booklet Maker System up to the Printer and dock it. If the system includes a RCT module, it is advisable to first dock the RCT module alone and then dock the Booklet Maker to the RCT.

⚠ CAUTION

To avoid damaging the communication cable connecting the Booklet Maker and the RCT, do not separate them to far.

⚠ CAUTION

To avoid the Upper Shift Tray from obstructing the RCT Top Cover, place the upper Shift Tray in the upright position. This is done by pulling the latch [A], pulling and then lifting, [B] then [C], the upper Shift Tray. Make sure the support [D] locks into position as illustrated.

If the system also includes a Trim Waste Conveyor, attach it to the RCT after docking. See Attaching the Trim Waste Conveyor above.

5 Turn the Printer on.

The Printer is now in Booklet maker mode and a staple icon is now present in the Printer display panel.

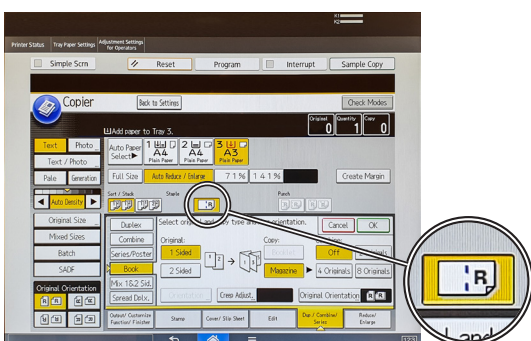
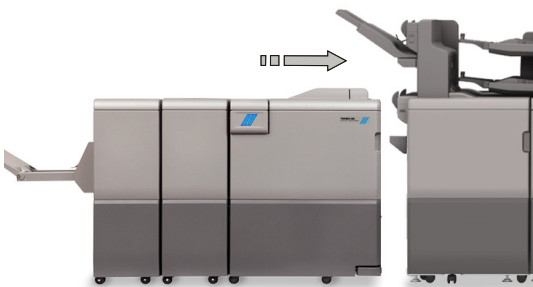
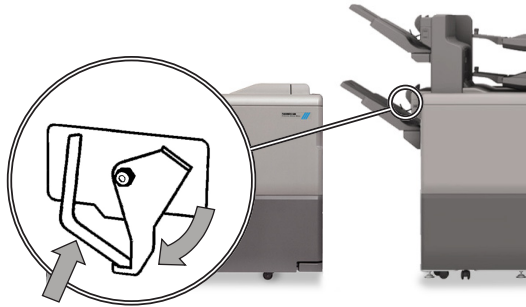

Undocking

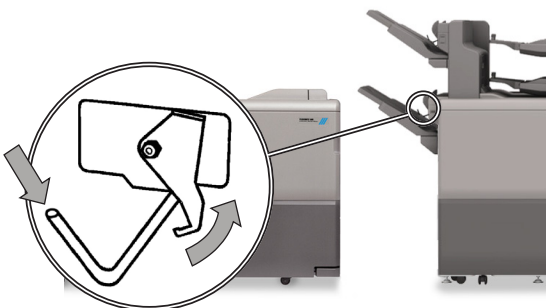
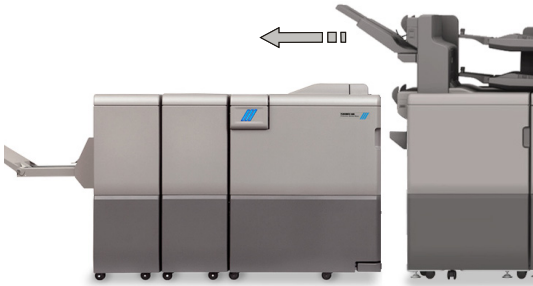
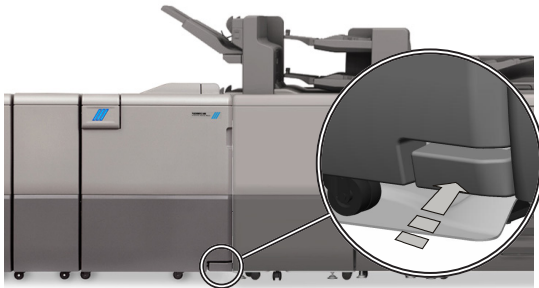

1 Turn the Printer off.

2 Push in the latch on the docking assembly and move the Booklet Maker System away from the Printer. If the system includes a RCT module, it is advisable to undock the Booklet Maker alone first and then the RCT.

⚠ CAUTION

To avoid damaging the communication cable connecting the Booklet Maker and the RCT, do not separate them to far.

⚠ CAUTION

If a Trim Waste Conveyor is attached to the RCT module, detach the TWC from the RCT module before undocking the RCT.

3 If the system includes a RCT, the upper Shift Tray can now be placed in its standard position. First lift the Shift Tray [A] so that the support [B] can be released, then let the upper Shift Tray down [C] to its lower position.

4 Take the Exit tray from the shelf on the Booklet Maker, and install it on the Printer's Finisher.

5 Lift up the Exit arm catcher and let the Exit paper arm down to the lower position.

6 Turn the Printer on.

7 How to use the Booklet Maker off-line as a stand-alone unit, is described in "On-line/Off-line" in section 2, "Making Booklets".

Intentionally blank.

2. Making Booklets

Guided Start

Guided Start is a function that takes you through all the basic settings the Booklet Maker System needs to start booklet production in a few easy steps. Customizing settings and fine adjustments are described later in this chapter.

Guided Start, step by step

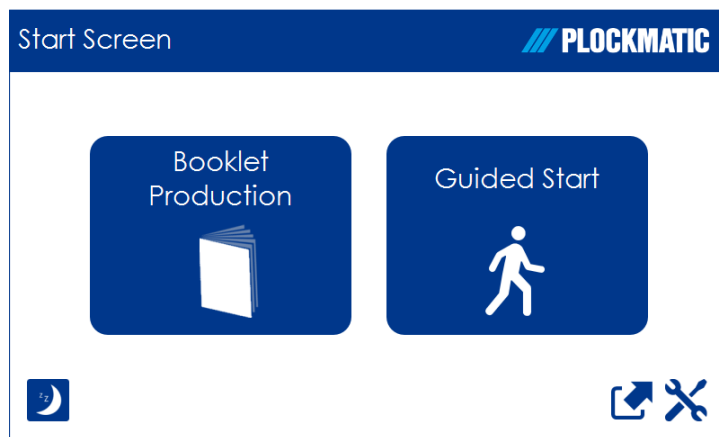

Guided Start

Press the [Guided Start] button to enter the Guided Start procedure.

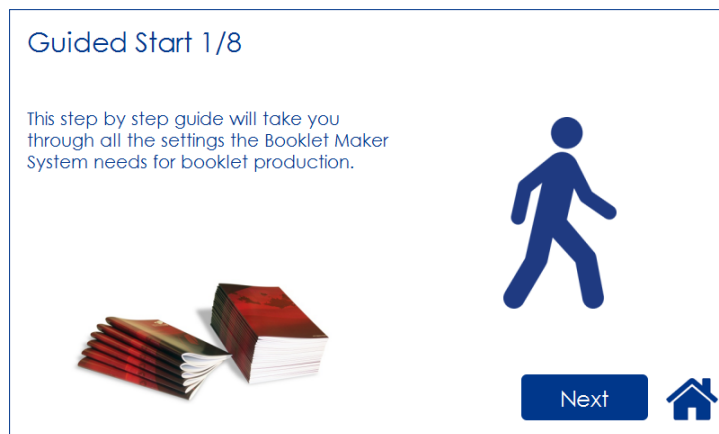

Guided Start 1/8

This is the first of up to 8 screens. Depending on how the system is configured and your selections during this procedure, the number of screens may be less than 8.

Configuration of the system also affects the information shown and button size will adapt to fit screen.

To proceed from one screen to another, press the [Next] button.

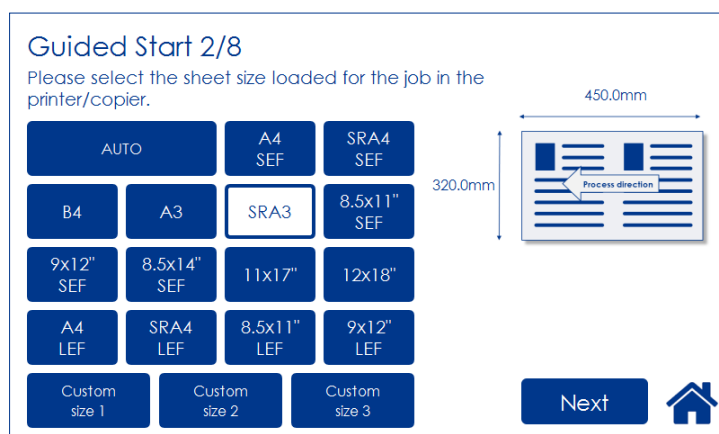

Guided Start 2/8

Select the sheet size loaded for the job by pressing the corresponding button.

For other sizes, follow “Custom sheet size” described in section “Basic Settings” below.

Guided Start 3/8

Please select the size of the finished Booklet

A5 booklet with AUTO
face trim

A5 booklet with NO
face trim

Custom Booklet Size
225.0 x 320.0mm

Edit

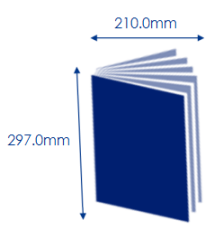

Back

Next



Guided Start 3/8

Choose either of two suggested formats (except for B4 which only has one suggested format).

When Face Trim is set to Auto, a minimum trim, based on the information from Set Thickness Sensor, is calculated.

To set the trim manually, follow “Finished Booklet size” described in section “Basic Settings” below.

Guided Start 4/8

Will a cover be added from the Plockmatic Cover Feeder?

Yes

No



Back

Next



Guided Start 4/8

Select whether the Cover Feeder is to be used or not and press the corresponding button.

Guided Start 5/8

Load covers in the Plockmatic Cover Feeder.

After loading the covers, press Next.

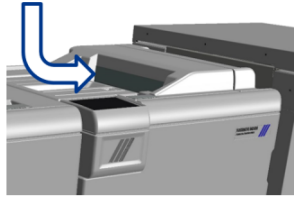

i Info: The side of the cover page that will be the outside cover of the book shall face downwards

Back

Next



Guided Start 5/8

Load the covers face down.

NOTE:

Make sure covers are same size as sheets fed to the Booklet Maker.

When using the bleed trim function and feeding covers at the same time, make sure covers loaded in Cover Feeder are same size as sheets fed from RCT to the Booklet Maker.

Guided Start 6/8

Shall the booklet be finished with a square spine?

Yes

No



i Info: For thin sets this feature will be automatically switched off.

Back

Next



Guided Start 6/8

Select whether the booklet should have a square formed spine or not and press the corresponding button.

If the job includes a small number of lighter weight sheets, the square forming action will be switched off.

Guided Start 7/8

Shall the booklet be finished with a creased cover?

Yes No



i Info: This feature is used to avoid image cracking on the spine of thin books (less than 6 sheets).

Back Finish 

Guided Start 7/8

Select whether the booklets should have a creased cover or not. This feature is used to avoid high area coverage toner cracking on the spine on booklets containing less than 6 sheets.

Press the corresponding button.

After you are done, press the [Finish] button to conclude the Guided Start.

Guided Start 8/8

Your Booklet Maker System is now ready for production.

Please start the production by sending the print job from the printer.

i Info: Check the appearance of the finished book and adjust any settings that might require adjusting from the "Settings for Booklet Production" page.





Guided Start 8/8

All settings needed to begin producing booklets are now set.



Start production by sending the print job from the printer.

Settings for Booklet Production

Input Sheet Size: SRA3 

Finished Booklet Size: Custom size 210.0 x 297.0mm 

Staple Status: ON Position: AUTO	Fold Position Position: -0.3mm	Cover Status: ON	Book Fold Status: ON Mode: MODE 3	Crease Status: ON Offset: -0.3mm
---	--	----------------------------	--	---

Booklets produced: 0 Clear   

After the job has been sent to the Booklet Maker System, the "Settings for Booklet Production" screen is shown.

From here you can customize and fine-tune settings, save the job and access the Tools screen.

Customizing and fine-tuning settings is described below in this section.

How to save jobs is described in section 4, "Jobs."

Tools are described in section 3, "Tools."

Press Home to return to the "Start Screen".

Changing settings

General procedure

Settings can be changed in one of two ways. “Temporary”, which means that the changes will remain until a new job is loaded or “Permanent”, which means that the changes will be stored as a job. This job can later be recalled.

Procedure for temporary changes:

From the Settings for Booklet Production screen, select the option you wish to alter and make your selection. Confirm by pressing the green [check] button. You will be returned to the Settings for Booklet Production screen



Procedure for permanent changes:

To keep your new settings, press the [Save current settings] button. Follow on screen instructions to save your current settings as a new job or to an existing job.

NOTE:

Choose either of the above mentioned procedures when changing size, stapling, trimming, covers or square forming as follows.

Depending on how the system is configured, the number of settings that can be selected varies. The information on the screen and the size of the buttons will adapt to fit the screen. Examples below show a fully configured system.

Basic settings

Input Sheet Size

Selecting standard paper sizes

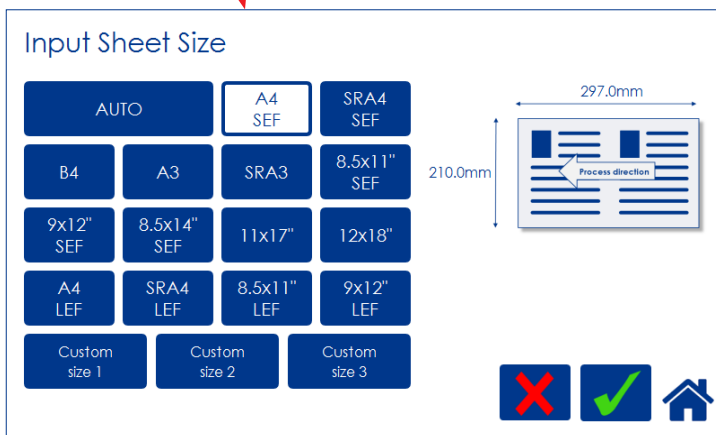
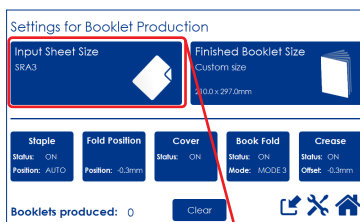

From the Settings for Booklet Production screen, press the [Input Sheet Size] button.

Select any standard paper size by pressing the corresponding button and save choice by pressing the green [check] button.

Depending on configuration, available standard paper sizes may differ. The LEF paper sizes are only available if there is a RCT installed.

For other paper sizes, follow “Custom input sheet size” as described on the next page.

NOTE:

Change of paper size will set Staple position, Fold position, BookFold and Crease to Auto and Cover to Off. Any Fine-tuning (see section below) and the “Booklets produced” counter will also be reset.

AUTO sheet size

AUTO means that the Booklet Maker will adjust to the paper size information sent from the printer. Auto Rotate will be turned on and a finished booklet size will be chosen from a predefined list i.e. the [Finished Booklet Size] button will be greyed out. No other settings will be affected.

Custom input sheet size

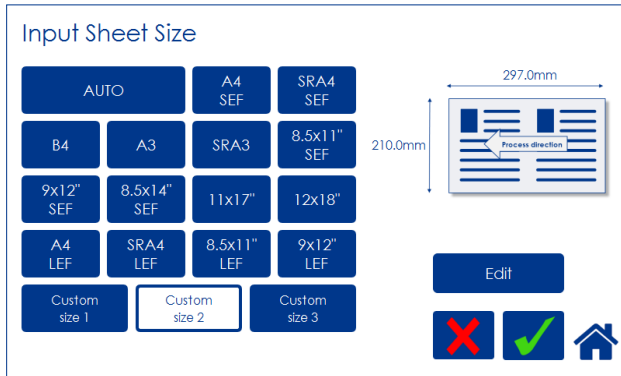

From the Input sheet size screen, press any of the Custom size buttons and then press the [Edit] button.

NOTE:
Changing to a Custom input sheet size will NOT change Staple position, Fold position, Cover, BookFold, Crease or Fine adjustment settings. The “Booklets produced” counter will still be reset.

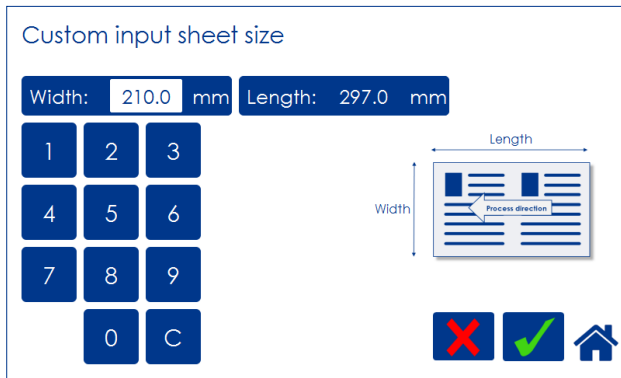

Select Length and/or Width and key in the desired value. Save the custom size format by pressing the [check] button.

Three different custom paper sizes can be stored.

NOTE:
A full number (incl. decimal point and fractions of an inch/mm) must be entered before the green [check] button appears.

Save setting by pressing the green [check] button.

Finished Booklet Size

Auto trimming

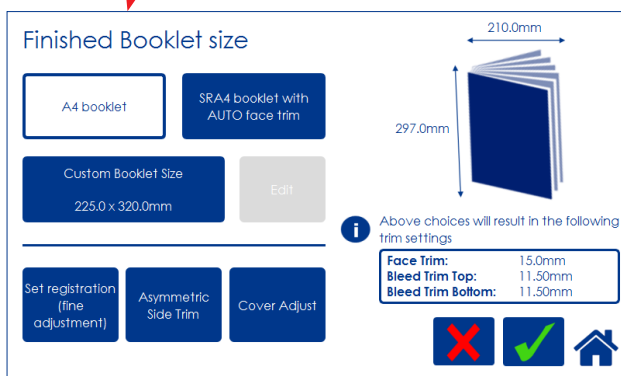
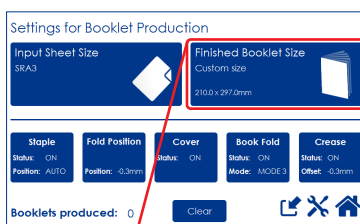

From the Settings for Booklet Production screen, press [Finished Booklet Size]. Trimming can now be set to either of two suggested formats (except for B4 which only has one suggested format) or Custom Booklet Size.

When Face Trim is set to Auto, a minimum trim, based on the information from Set Thickness Sensor, is calculated.

For custom sized booklets, see below.

Custom booklet size

2

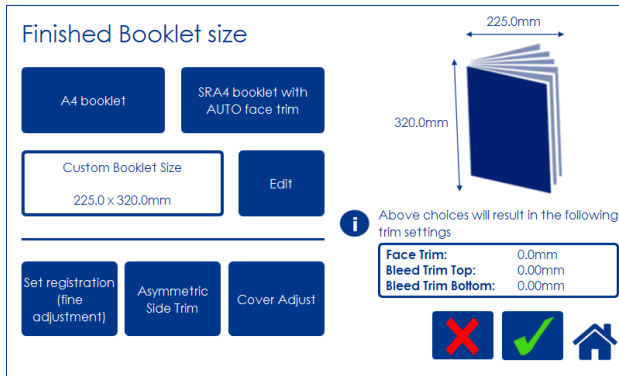

To set the trim manually, press [Custom Booklet Size] and then [Edit].

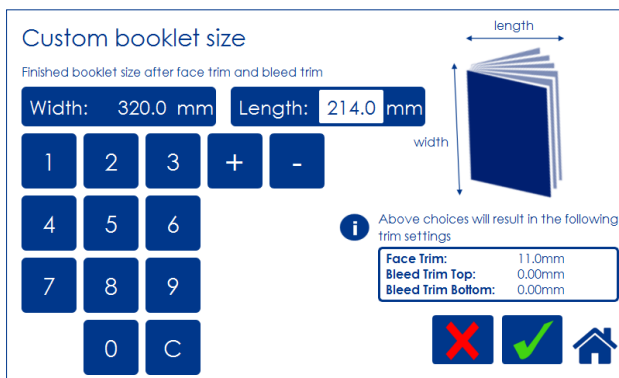

To adjust the amount of face trim, press the number on the [Length] button and type in the desired length of the booklet, decimals included. Also, the [plus] and [minus] buttons can be used to change the numbers. The amount of face trim is displayed in the box.

Press the green [check] button to confirm or continue adjusting the amount of bleed trim.

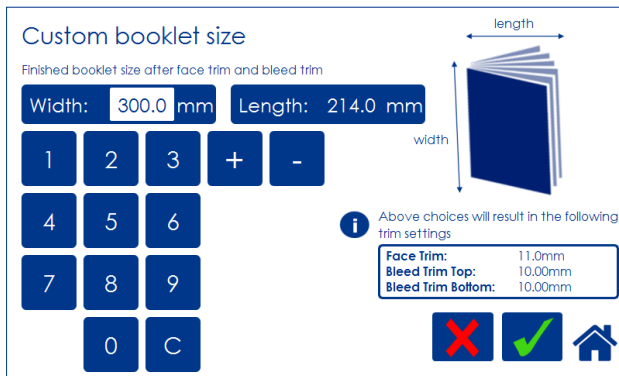

To also adjust the amount of bleed trim, press the number on the [Width] button and type in the desired width of the booklet, decimals included. Also the [plus] and [minus] buttons can be used to change the numbers. The amount of bleed trim is displayed in the box.

Press the green [check] button to confirm.

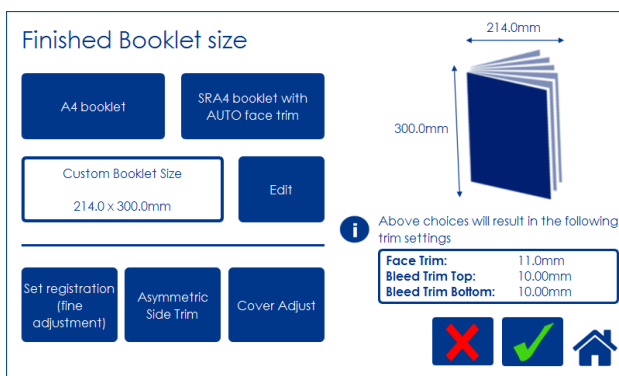

Back in the Finished Booklet size screen, the size of the finished booklet and the amount of face and bleed trim is displayed.

Press the green [check] button to confirm.

NOTE:

When using the bleed trim function and feeding covers at the same time, make sure covers loaded in Cover Feeder are the same size as sheets fed from the RCT. According to the example on the left, covers must be 300x450mm.

Customizing settings

Staple

Selecting stapling On or Off

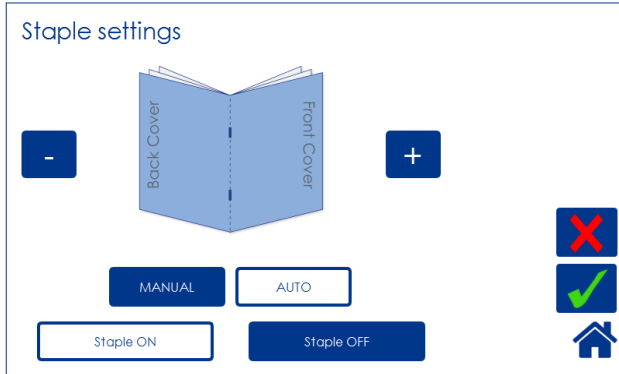

From the Settings for Booklet Production screen, press the [Staple] button.

2

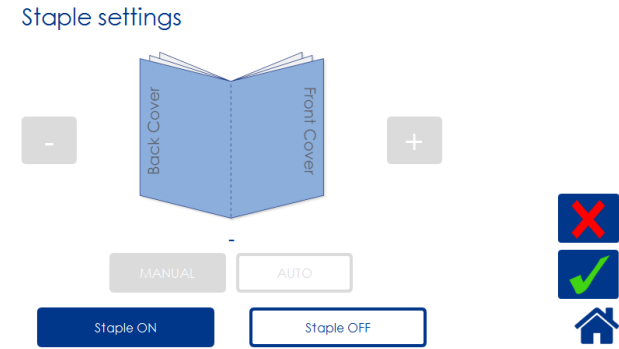

Select On or Off by pressing the corresponding button and save setting by pressing the green [check] button.

Adjusting staple position

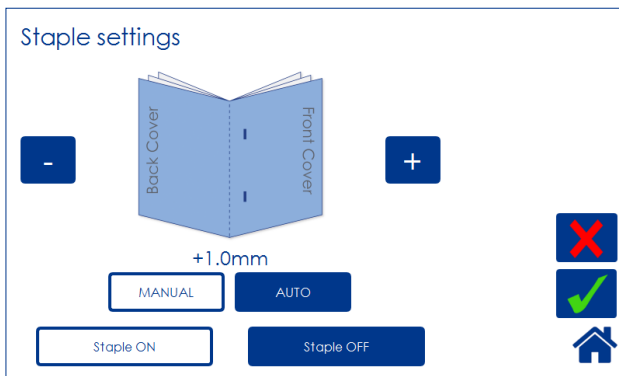

From the Settings for Booklet Production screen, press the [Staple] button.

Set to Manual, the staple position can be altered up to 3 mm (0.12") on either side of the fold. Press the [+] button move position closer to the lead edge and press the [-] button move position closer to the trail edge. Save setting by pressing the green [check] button.

NOTE:

This change can be performed during run.

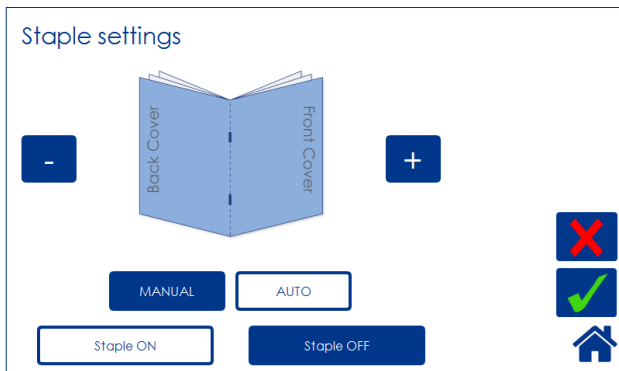

Set to Auto, the Booklet Maker uses the set thickness sensor to adjust the staple position. Press the [Auto] button and save setting by pressing the green [check] button.

Fold position

Adjusting fold position

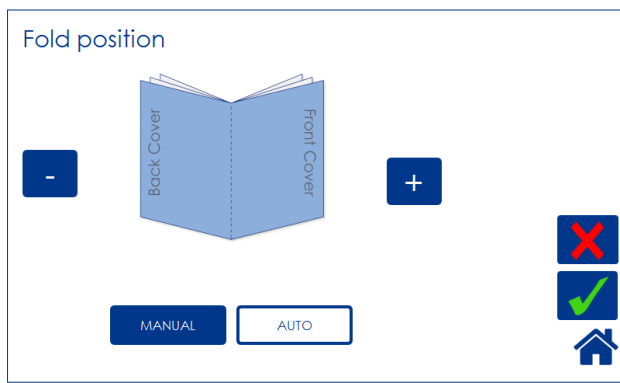
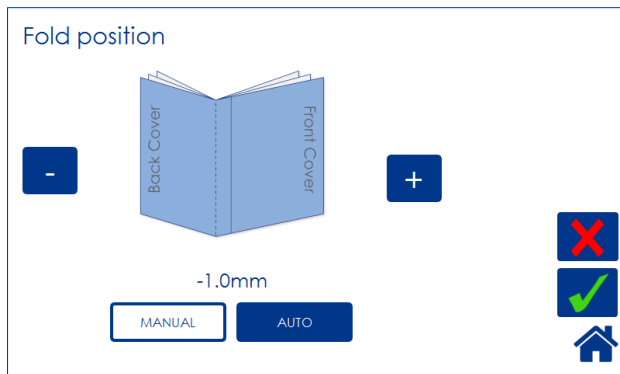

From the Settings for Booklet Production screen, press the [Fold position] button.

The position of the fold can be changed up to 3 mm (0.12") on either side of the center of the set. Press the [+] button move position closer to the lead edge and press the [-] button move position closer to the trail edge. Save setting by pressing the green [check] button.

NOTE:

This change can be performed during run. You may want to turn off trimming to see the result more clearly when you move the fold position.

Set to Auto, the Booklet Maker uses the set thickness sensor to adjust the fold position. Press the [Auto] button and save setting by pressing the green [check] button.

Cover

General

If the optional Cover Feeder is installed, the [Cover] button will be visible in the control panel. If enabled, the cover feeder will automatically feed one sheet to each set from the printer, or one sheet to each manually, hand-fed set.

A higher paper weight, pre-printed cover is fed to the set waiting in the compiler. The set and the cover are then stapled and folded together.

Depending of system configuration, the booklet is then fed to the Belt Stacker, BookFold Module or Trimmer.

NOTE:

Make sure sheets fed from Cover Feeder are the same size as sheets fed to booklet maker from printer or by hand. When using an RCT, see Note under "Changing settings, Finished Booklet Size, Custom booklet size".

NOTE:

After selecting Cover [Yes], when the green [check] button is pressed, the Cover Feeder will try to move the first sheet into feeding position. Therefore, load covers before pressing the green [check] button to avoid the error message "Load covers" from being shown. See section 1, "Basics" for how to load covers.

The Cover Feeder can also be used as a regular feeder. See section 3, "Tools".

Cover

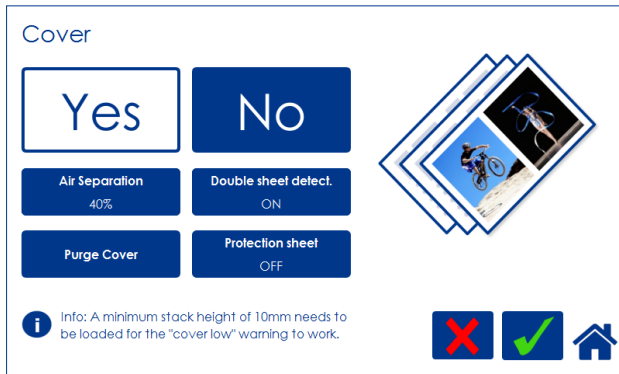

From the Settings for Booklet Production screen, press the [Cover] button. Press the [Yes] button and confirm by pressing the green [check] button.

Air Separation

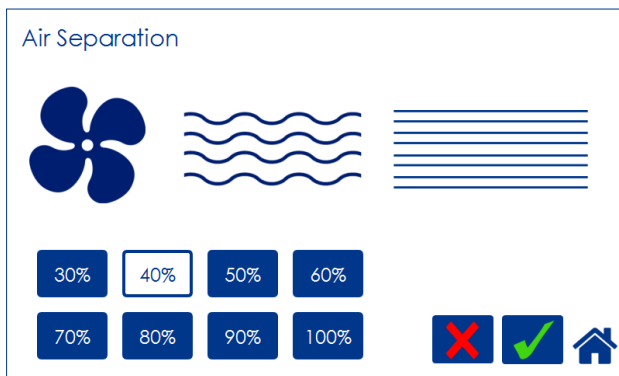

You may want to increase the Air flow when running thick, heavy covers. From the Cover screen, press the [Air separation] button. Set the desired amount of air flow by pressing the corresponding button and save setting by pressing the green [check] button. Default setting is 40%.

Double Sheet Detection

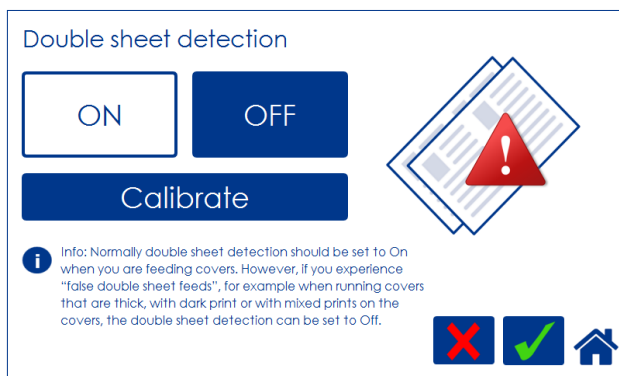

From the Cover screen, press the [Double sheet detection] button.

Set the detection to On or Off by pressing the corresponding button and save setting by pressing the green [check] button.

Normally, double sheet detection should be set to "On" when you are feeding covers. However, if you experience "false double sheet feeds", for example when running covers that are thick, with dark print or with mixed prints on the covers, the double sheet detection can be set to Off.

 **NOTE:**

Misfeed detection will work regardless of how Double Sheet detection is set.

Purge Cover

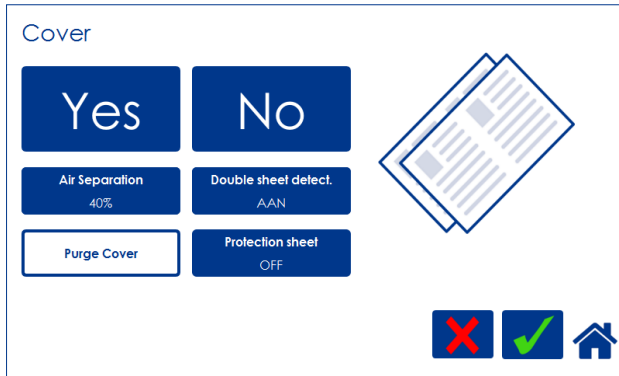

The Purge mode is used when you want to completely empty the Cover Feeder from covers.

- 1 Remove all cover sheets from the bin.
- 2 Press the [Purge Cover] button and confirm by pressing the green [check] button. The pre-fed cover sheet will now be fed into the Booklet Maker to the stapling area, but will not be stapled.
- 3 Open Top Cover and remove the cover sheet.

NOTE:

If you open and close the Top Cover without removing the cover sheet, the cover sheet will be stapled and folded and then fed to the stacker.

Protection sheet

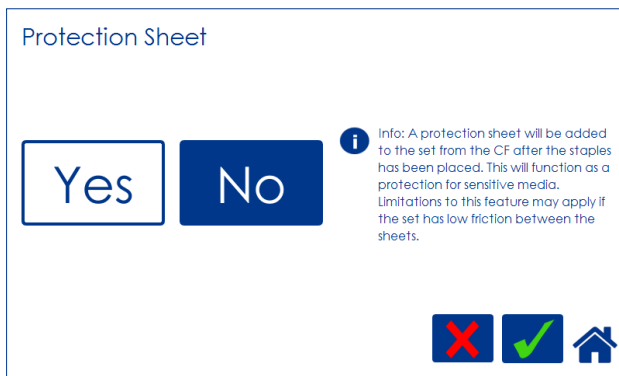

In case you are running sensitive media you can use the Cover Feeder to feed a protection sheet.

From the Cover screen, press the [Protection sheet] button, press the [Yes] button and press the green [check] button to confirm.

The sheets in the set will be jogged and stapled before the protection sheet is fed.

The set and the protections sheet will then be folded together.

NOTE:

After choosing Protection sheet, when the green [check] button is pressed, the Cover Feeder will try to move the first sheet into feeding position. Therefore, load covers before pressing the green [check] button to avoid the error message "Load covers" from being shown. For loading covers or protection sheets, see section 1, "Basics".

BookFold

General

The BookFold Module has three different settings - Manual, Auto and Off.

In Manual mode, there are eight different modes of BookFold pressure to choose from.

Set to Auto, information from the set thickness sensor in the Booklet Maker is used to calculate the most appropriate mode between 1 and 7. See guidance table below.

Select Off to bypass the BookFold Module without any square forming action.

NOTE:

When the BookFold Module is set to Auto and the booklet has less than approximately 6 sheets/booklet, the BookFold Module will bypass the square forming action. **continued on next page**

Mode 8 is a heavy duty setting in case of extra demanding media. Mode 8 is not included in the Auto setting and therefore must be selected manually.

Use the manual modes to override the auto function. There are eight different manual modes to select from.

Table below is approximate numbers and is based on 80 gsm / 20 lb Bond sheets.

Mode	Number of sheets in the set	Notes
1	Approximately 6 to 10	
2	Approximately 11 to 16	
3	Approximately 17 to 22	
4	Approximately 23 to 29	
5	Approximately 30 to 35	
6	Approximately 36 to 43	
7	Approximately 44 to 50	
8	Heavy duty setting in case of extra demanding media.	

BookFold pressure settings guidance table

The table below shows highest supported BookFold pressure settings on PBM500e and PBM350e Production Booklet Maker systems.

 **NOTE:**

The following table indicates maximum BookFold pressure setting that can be used on the PBM500e and PBM350e Production Booklet Maker systems without slowing the printer down.

Number of sheets	A4	A3	SRA3	8.5x11"	11x17"	12x18"
1-5	2	4	7	1	4	7
6-10	4	7	8	4	7	8
11-15	7	8	8	7	8	8
16-20	7	8	8	7	8	8
21-30	8	8	8	8	8	8
31-50	8	8	8	8	8	8

 **NOTE:**



When square forming thick booklets with a thin cover, the cover sheet may be spaced away from the body of the book and/or it may be crushed in the square forming process.

This phenomenon is eliminated/reduced by using a heavier media as the cover. If using a heavier cover is not an option, using a lower BookFold pressure setting in the square forming process may improve booklet appearance.

Selecting BookFold pressure setting

Book Fold



MANUAL AUTO OFF

Info: When the Book Folder is set to [Auto] and the booklet has less than approximately 6 sheets/ booklet, the Book Folder will bypass the Square folding action, transporting the booklet out to the Belt stacker.

1 2 3 4 5 6 7 8

- +

From the Settings for Booklet Production screen, press the [BookFold] button.

Press the [Manual] button and select the desired amount of pressure using the [+] and [-] buttons. Save setting by pressing the green [check] button.

Crease

The Crease function makes it possible to crease the cover sheet of the booklet in order to avoid toner cracking or flaking at the fold.

Crease Mode

2

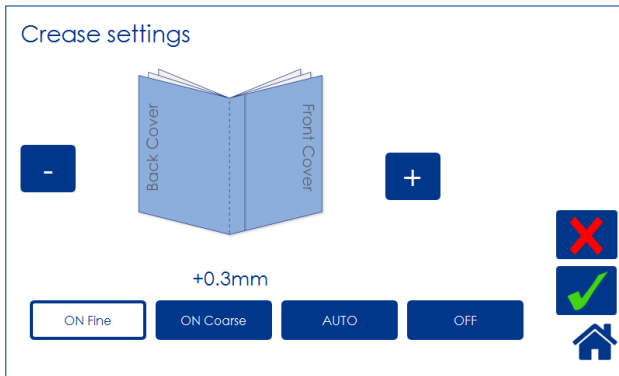

From the Settings for Booklet Production screen, press the [Crease] button.

Press the corresponding button to choose [On Fine], [On Coarse], [AUTO] or [OFF].

Normally Fine is recommended for cover sheets less than 120 gsm / 32 lb Bond.

For sheets heavier than that, select Coarse.

Choose Auto function to let the system automatically select between fine and coarse creasing, based on information from the printer. If 120 gsm / 32 lb Bond is loaded in the printer, the coarse tool will be selected.

When you want to turn the Creaser off, select Off.

Press the green [check] button to confirm.

Crease position

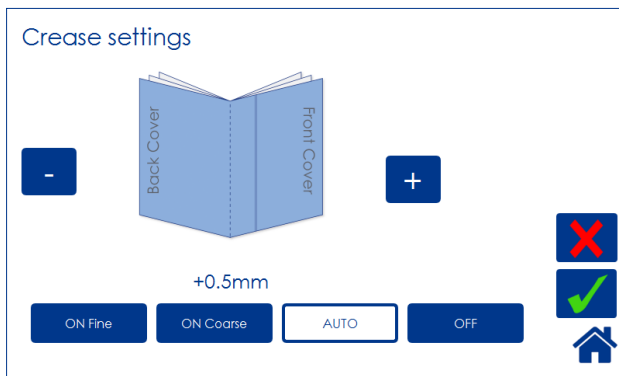

The crease is initially set to the center of the sheet. Operators have the option to offset the position of the crease using the [+] or [-] buttons. Press the [+] button move position closer to the lead edge and press the [-] button move position closer to the trail edge. Regardless if you chose Fine or Coarse creasing, each press of a button will move the crease 0.1 mm / 0.004".

When done, press the green [check] button to confirm.

The illustration shows that the crease is offset 0.5 mm towards the trail edge.

Fine-tuning booklet appearance

Set registration (fine adjustment)

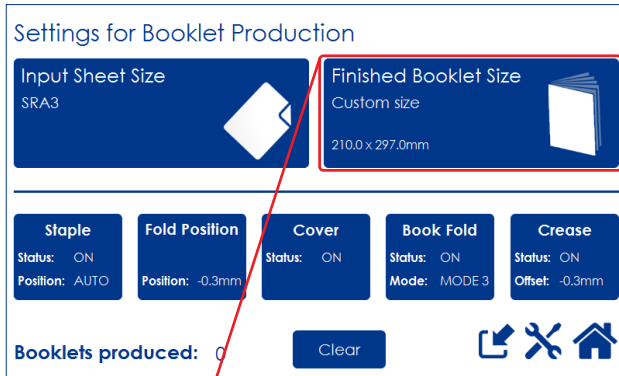

You can fine-tune the booklet quality by adjusting the jiggers in the booklet maker. From the Settings for Booklet Production screen, press the [Finished Booklet Size] button.

2

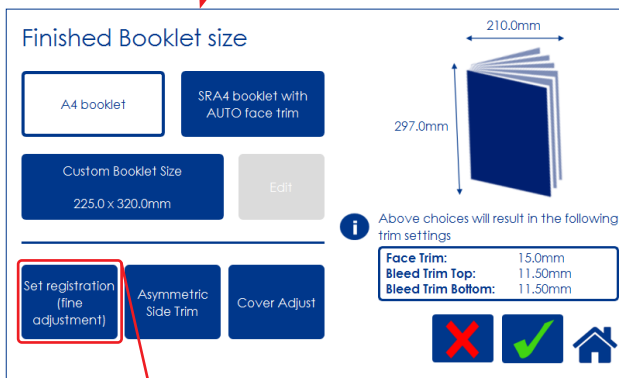

From the Finished Booklet size screen, press the [Set registration (fine adjustment)] button.

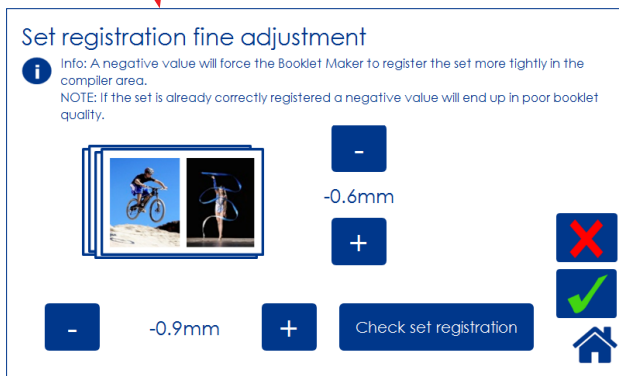

Press the [-] and [+] buttons to alter either or both registration values. Negative value means a tighter registration.

NOTE:
Too tight of a setting may worsen the result.

After setting registration value, press the [Check set registration] button and follow the instructions on screen.

If you are satisfied with the registration, confirm by pressing the green [check] button. If not, press the [-] and [+] buttons to enter new value. Check out the new value by pressing the [Verify adjustments] button.

Press the green [check] button when you are satisfied.

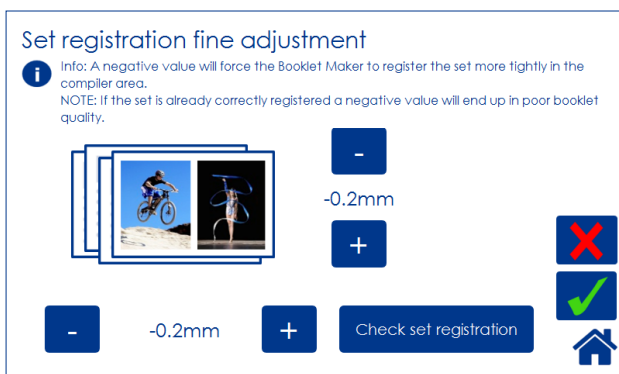

Bleed Trimmer - Asymmetric Side Trim

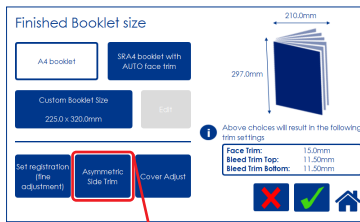

2

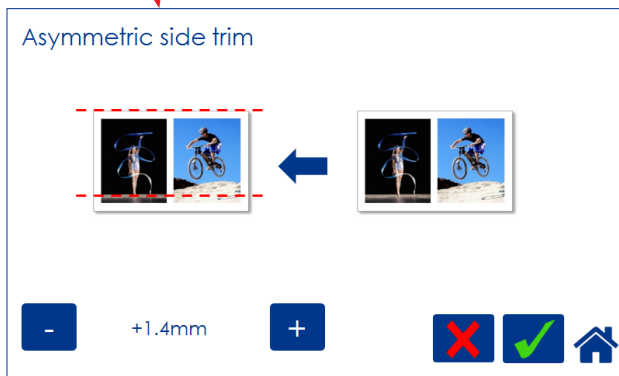

From the Finished Booklet size screen, press the [Asymmetric Side Trim] button.

Choose Asymmetric Side Trim if you want to offset the bleed trim. Move using the [+] and [-] buttons and press the green [check] button to save setting.

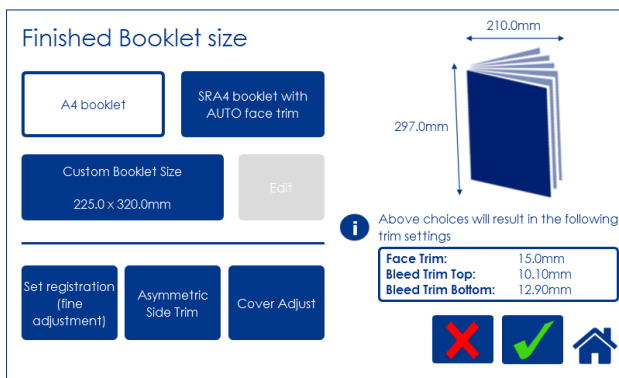

Settings as in the example above would result in a booklet with trim settings shown in the image to the left.

Bleed Trimmer - Cover Adjust

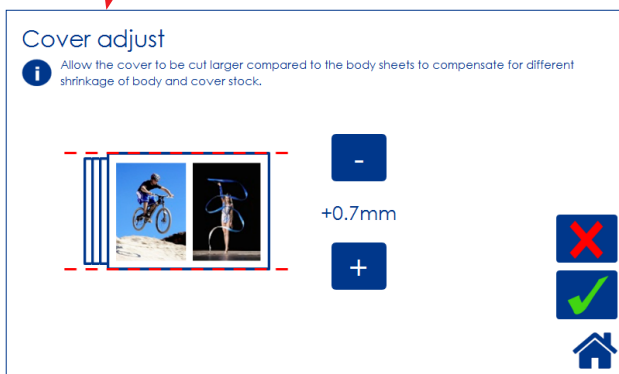
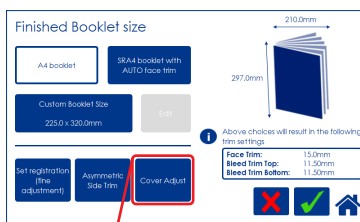

From the Finished Booklet size screen, press the [Cover Adjust] button.

Choose Cover Adjust to compensate for different shrinkage of body- and booklet cover stock. This can occur under some conditions and can be caused by different paper stocks shrinking due to the heat and pressure of the fusing process.

Adjusting these settings can improve booklet appearance, especially if the cover is dark and the body sheets are bright.

The shown example will make the cover sheet 0.7mm bigger than the body stock.

On-line/Off-line

The Booklet maker can be operated in two modes. On-line mode, when used together with the printer, or off-line mode, working as a stand-alone unit.

Off-line mode

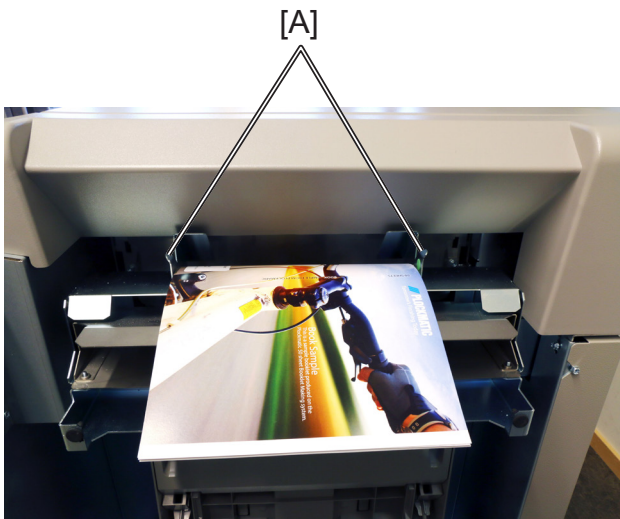

- 1** Follow “Undocking the Booklet maker” in section 1, “Basics”.
- 2** Adjust the hand feeding paper guides [A] to the correct paper size.
- 3** Turn on the Booklet maker.

The Booklet maker is now in stand-by and will start automatically when a set is fed into the Booklet maker. If settings need to be changed, follow “Changing settings” earlier in this section.

If the hand feeding process needs to be aborted or interrupted, use the Stop button in the user interface display.

On-line mode

Follow “Docking the Booklet maker” in section 1, “Basics”.

Begin On-line Production

2

- 1 Make sure that the staple icon [B] is present on the printer control panel. If not, turn off the Printer and Booklet Maker. First turn the Booklet Maker ON and then turn the Printer ON.
- 2 Make sure that the Booklet Maker system is set according to your job specification.
- 3 Select [Paper tray] [A].
- 4 Select [Staple icon] [B].
-  **NOTE:**
Make sure correct original orientation [D] is selected.
- 5 Select Colour/Black & White [C].
- 6 Select [Dup / Combine / Series] [E].
- 7 Select [Book] [F].
- 8 Select [1 Sided] [G] if your originals are only printed on one side or [2 Sided] [H] if they are printed on both sides.
- 9 Select [Magazine] [I].
- 10 Select [Quantity] [J].
- 11 Press the [Start key].

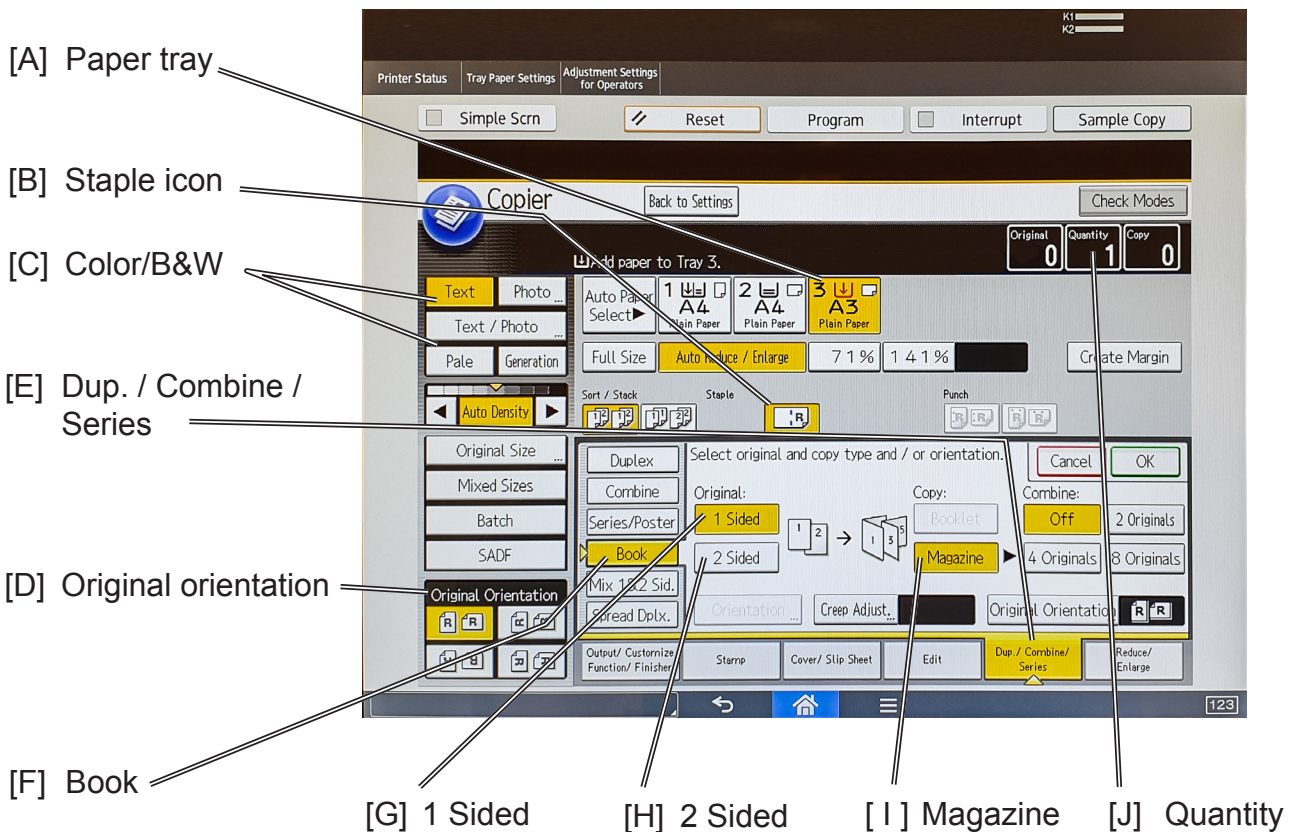

3. Tools

The Tools screen

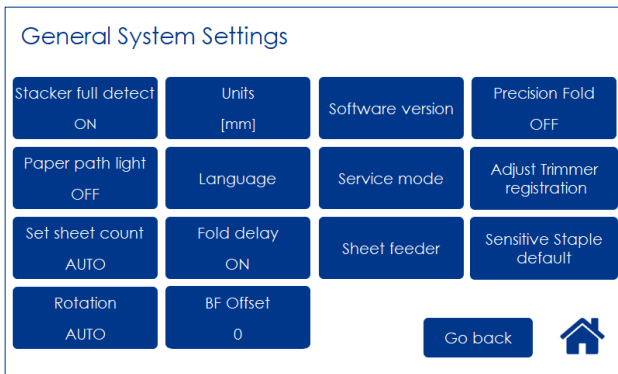

 From the Start screen or the Settings for Booklet Production screen, press the [Tools] button to get to the General System Settings screen. Select the setting you want to change by pressing the corresponding button.

Press the green [check] button to save your changes.

Stacker full detection

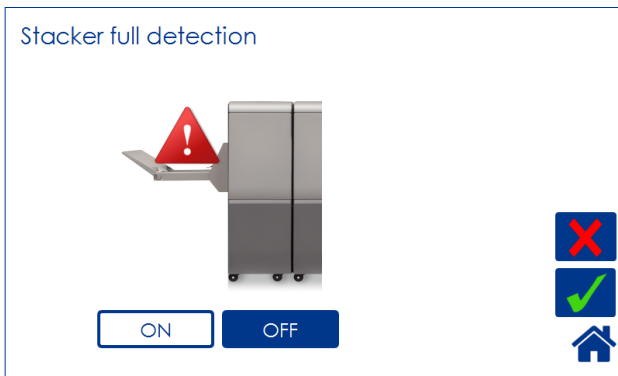

Set Stacker Full Detection to ON if you want the system to stop and cycle down when the stacker is full.

Units

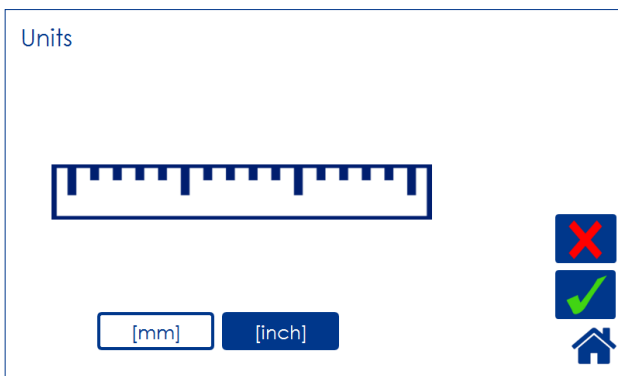

Select millimeters or inches by pressing the corresponding button.

Software version

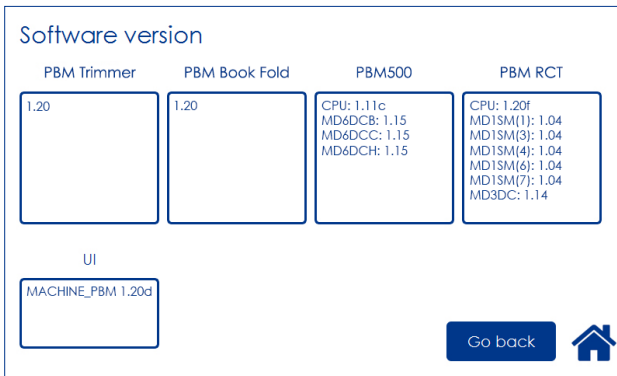

Select module by pressing the corresponding button to display the software version. Press [Exit] button to go back to the Settings screen.

3

Precision Fold

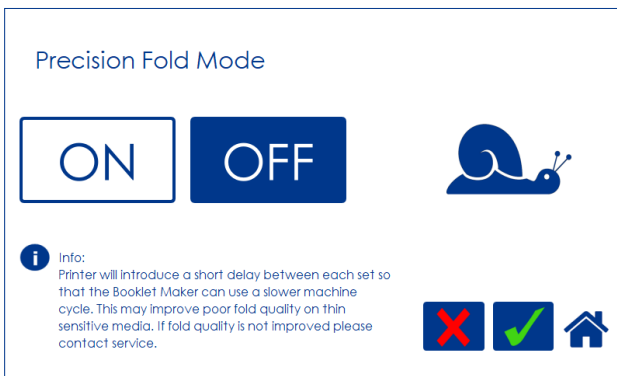

The printer will introduce a short delay between each set so that the Booklet Maker can use a slower machine cycle. This may improve poor fold quality on thin sensitive media. Using Precision Fold Mode may also reduce productivity.

The default setting for Precision Fold Mode is [On]. Unless the job is saved, the Booklet Maker will return to the default setting when the power is turned off. How to save jobs is described in section 4, "Jobs."

Paper path light

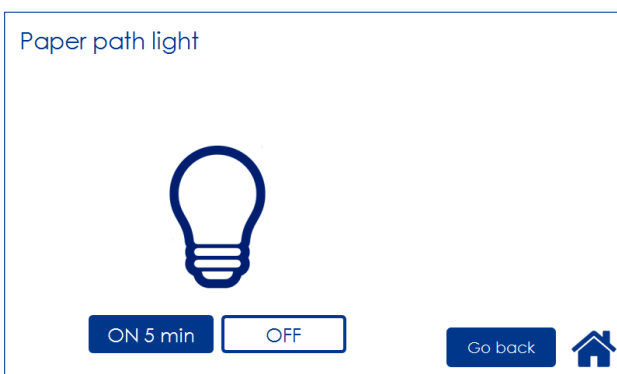

This function is for service purposes. To turn the paper path light on, press [ON 5 min] button and save by pressing the [OK] button.

Language



Select desired language by pressing the corresponding button.

Service mode

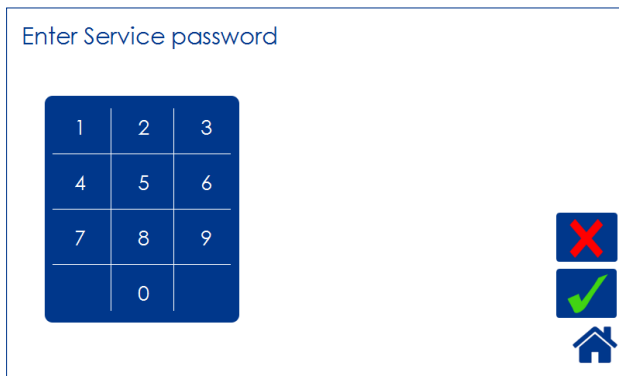

This function is for authorized service personnel only and is password protected.

Adjust Trimmer registration

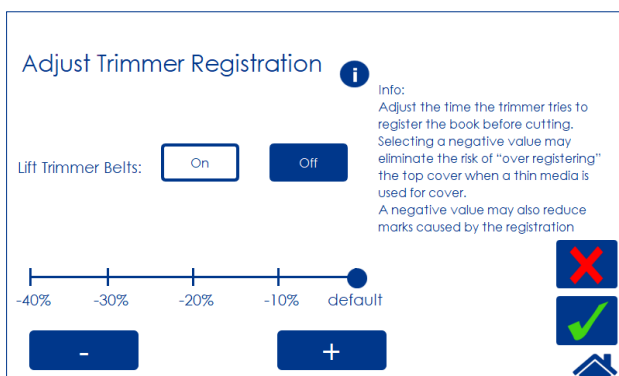

Adjust the time the trimmer tries to register the booklet before trimming. Selecting a negative value may eliminate the risk of “over registering” the top cover when a thin media is used for cover. A negative value may also reduce marks caused by the registration.

Set Lift trimmer Belts to [On] to relieve the trimmer belt pressure on the top page of the cover. This may help the top cover to retake its original flat shape if it should have been curled while registering. The default setting for Lift trimmer belts is [On].

Unless the job is saved, the Booklet Maker will return to the default setting when the power is turned off. How to save jobs is described in section 4, “Jobs.”

Set sheet count

Set sheet count

i Manually setting the number of sheets per set can for some applications improve productivity. In addition, for some “special” applications you may get a warning indicating that the job will not run correctly without setting the set sheet count. Examples of such jobs are when the multi-cut function in the Trimmer is used or when a high book fold mode is used on a job with low sheet count. By setting the Set Sheet Count the Booklet Maker System can calculate if extra time or less time between the sets is required and ask the printer to increase this set gap.

Number of sheets per set:



Manually setting the number of sheets per set can improve productivity for some applications. In addition, for some “special” applications you may get a warning indicating that the job will not run correctly without setting the sheet count. For example when the multi-cut function in the Trimmer is used or when a high Book-Fold pressure setting is used on a job with low sheet count. By setting the Set Sheet Count, the Booklet Maker System can calculate if more or less time is required between the sets and ask the printer of increase this set gap.

3

Fold delay

Fold Delay



i Info: The set will stay under pressure between the fold rollers for extended time to provide a flatter fold. This only applies to sheet sizes shorter than 400mm or 15.8” and for applications over 10 sheets. In hand feed mode and feeder mode from the CF the fold delay will automatically switch off.



With this feature, the set will stay under pressure between the fold rollers for extended time to provide a flatter fold. This only applies to sheet sizes shorter than 400mm or 15.8” and for applications over 10 sheets. In hand feed mode and feeder mode from the CF, the fold delay will automatically switch off.

Sheet feeder

Sheet feeder

Load a stack of pre-collated sets in the Cover Feeder

Number of sheets in each set:



Status: Off

Booklets produced: 0



This function allows you to use the Cover Feeder as a regular Feeder. Load the Cover Feeder, enter the desired number of sheets in each set and press the [Start] button to begin folding. Press the [Stop] button to stop.

See section 1, “Basics”, for how to load the cover feeder.

See section 2, “Making Booklets” for how to adjust Air Separation and Double sheet detection.



NOTE:

To avoid the error message “Load covers”, load covers before pressing the [START] button.

Sensitive Staple

Sensitive Staple Mode

Right 30% 40% 45% 50% 55% 60% default

Left 30% 40% 45% 50% 55% 60% default

i Info: The Booklet Maker will close the staple with less force to reduce the risk of damaging sensitive media. Note that on some applications this might result in staple not closing properly.

The Booklet Maker will close the staple with less force to reduce the risk of damaging sensitive media. Note that on some applications this might result in staple not closing properly.

Unless the job is saved, the Booklet Maker will return to the default setting when the power is turned off. How to save jobs is described in section 4, “Jobs.”

Auto Rotate

Auto Rotate

i Info: Auto Rotate will automatically rotate ALL sheet sizes sent from the printer in long edge feed to the Booklet Maker system. Recommendation is to keep this ON most of the time.

Auto Rotate OFF Auto Rotate ON

If your system includes the optional RCT module, you can select whether you want Auto Rotate function to be ON or OFF by pressing the corresponding button.

It is recommended to keep this ON. When turned on, the Rotator will automatically rotate all sheet sizes sent from the printer in long edge feed, enabling higher printer productivity.

Selecting OFF will prevent sheets from being rotated when possible. Sheets lengths has to exceed 275mm / 10.6”. Otherwise Auto Rotate will automatically be changed to ON and sheets will be rotated.

BookFold offset

The BookFold pressure setting is set to a standard that should suit most applications. Operators have the option of sharpening or softening the square edges based on application or preference. Customizing this setting will affect modes 1 to 7 but not mode 8.

Book Fold offset

i Info: Changing this value will apply to all jobs using the Book Fold feature. Only change this offset value if you think the AUTO setting of the BF module always produces a weak square fold.

-10 0 +10

Select sharper edges by pressing the [+] button or softer edges by pressing the [-] button.

NOTE:
BookFold offset affects modes 1 -7 only.

Intentionally blank.

4. Jobs

Handling jobs

The Booklet Maker has a maximum storage capacity of 20 different jobs. To make temporary changes in the actual job settings or temporary changes of a stored job, see section 2, "Making Booklets."

From the Start screen, press the [Jobs] button to be able to store, change or delete jobs.

Saving a Job

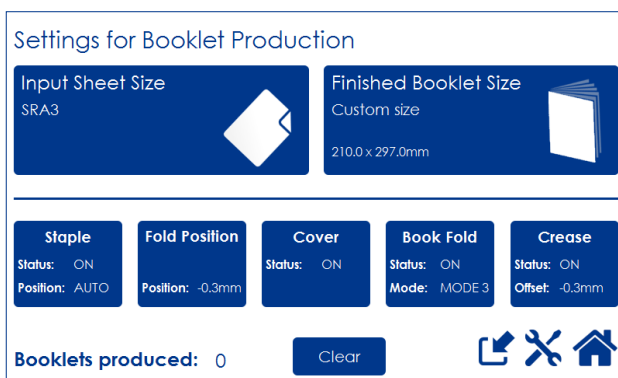

To store a job, press  from the **Settings for Booklet Production** screen.

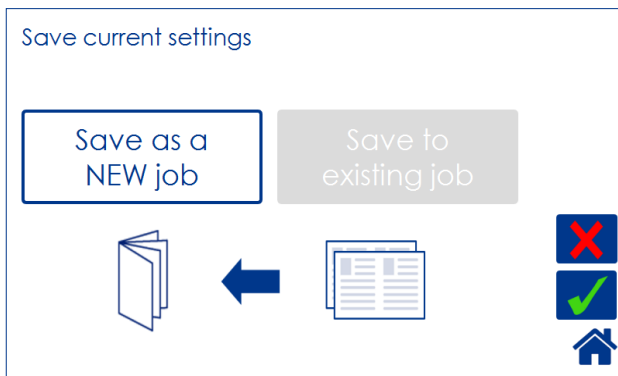

Press the [Save as a NEW job] button and then press the green [check] button to continue.

The [Save to existing job] button is only available if a job is currently loaded.

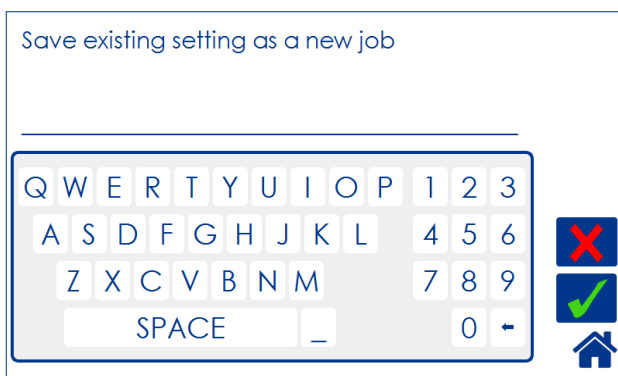

Enter a job name and save by pressing the green [check] button.

To delete last character, press the [←] button

Opening and handling stored Jobs

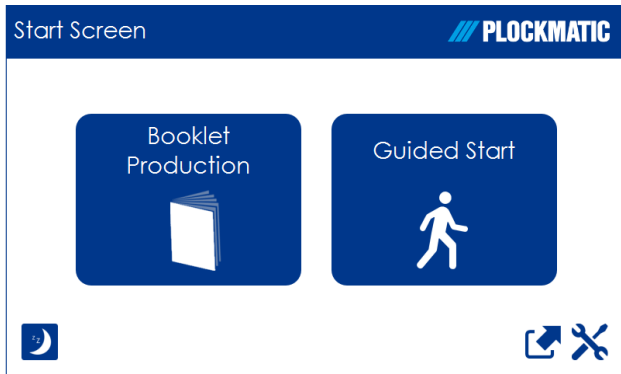

To access already stored jobs, press  from the **Start Screen**.

4

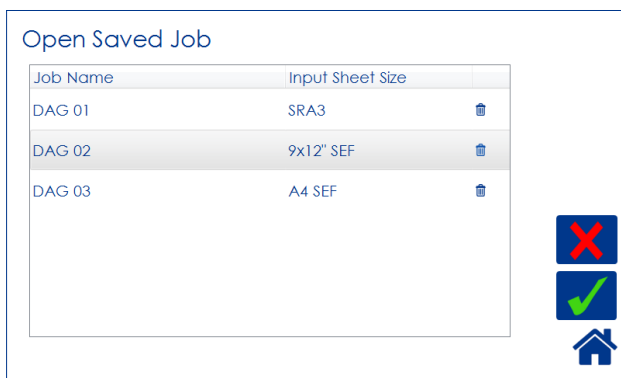

Open (load) any stored job by pressing the job and confirm by pressing the green [check] mark.

Delete any stored job by pressing the job button, the waste bin symbol and then confirm by pressing the [Yes] button.

 **NOTE:**
The currently loaded job cannot be deleted.

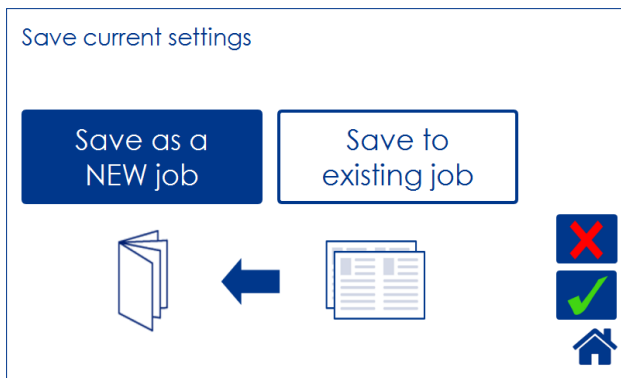

The button [Save to existing job] is only available if a saved job is currently loaded. Press the [Save to existing job] button to overwrite the currently loaded job.

Press the green [check] button to confirm.

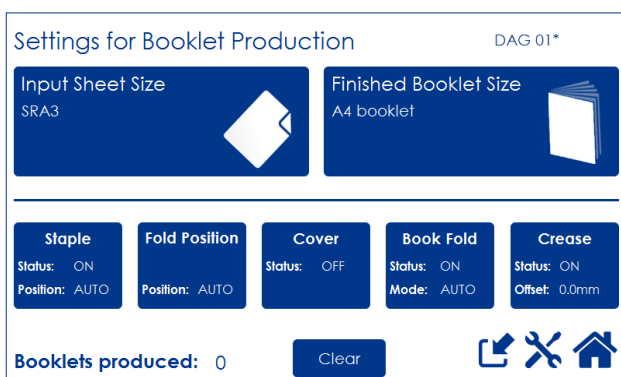

The name of the currently loaded job is shown in the upper right corner. An asterisk next to the name shows that changes to the job have been made and that the changes have not yet been saved.

5. Clearing Misfeed(s)

Clearing misfeed(s)

General

If a misfeed condition should occur, it is indicated on the Booklet Maker display. The message “Clear Misfeed(s)”, an error code and the location of the misfeed is displayed. See examples below.

Attention!
Paper misfeed detected at the following points, please clear the paper path.
Area A: CT-204, Clear misfeed!

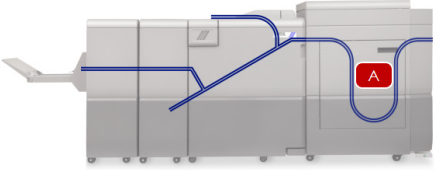

Misfeeds in the Rotate Crease Trim Module are indicated by the error code RCT-XXX.

Attention!
Paper misfeed detected at the following points, please clear the paper path.
Area B1: BK-201, Clear misfeed!

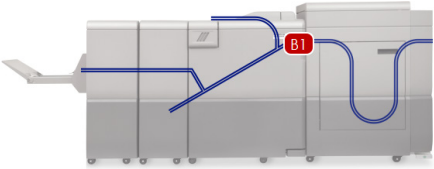

Misfeeds in the Booklet Maker are indicated by the error code BK-XXX and visually where in the Booklet Maker (B1, B2 or B3) the misfeed occurred.

Attention!
Paper misfeed detected at the following points, please clear the paper path.
Area C: BF-204, Clear misfeed!

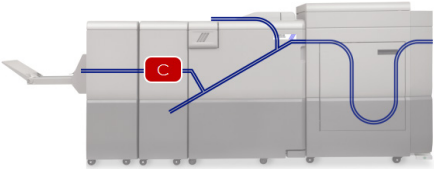

Misfeeds in the BookFold Module are indicated by the error code BF-XXX.

Attention!
Paper misfeed detected at the following points, please clear the paper path.
Area D: TR-204, Clear misfeed!

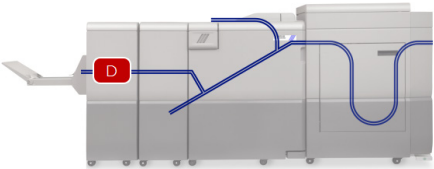

Misfeeds in the Trimmer are indicated by the error code TR-XXX.

RCT Module

Clearing misfeed(s) in the paper path



⚠ CAUTION

To avoid the Upper Shift Tray from obstructing the RCT Top Cover, make sure the upper Shift Tray is in the upright position before opening the RCT Top Cover. See "Docking the Booklet Maker" in section 1, "Basics".

Infeed "A" area and exit "D" area

5

- 1 Open the top cover.
- 2 Lift up the baffles marked "A" and "D" if needed.
- 3 Remove any jammed/misfeed sheets.
- 4 Lower the baffles "A" and "D" to normal position
- 5 Missfeed(s) in the trimmer areas are rolled out by rotating the rubber surfaced pinch roller [A].
- 6 When necessary, remove Trim waste guides [C]. See section 1, "Basics".
- 7 Close the top cover.

⚠ WARNING:

Do not put your fingers within knife protections (B). Doing so may result in injury.

⚠ CAUTION:

Under no circumstances should jams around the trimmer blades be cleared using metallic tools. The edges are very fragile and easily damaged.

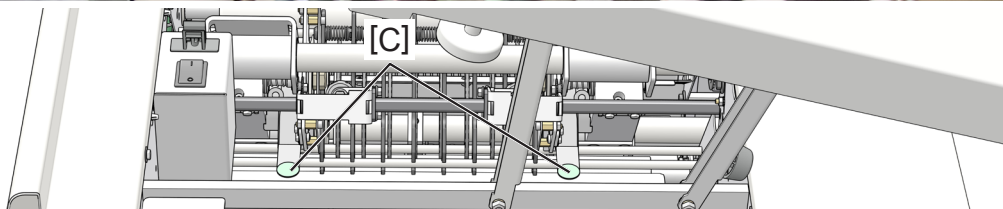
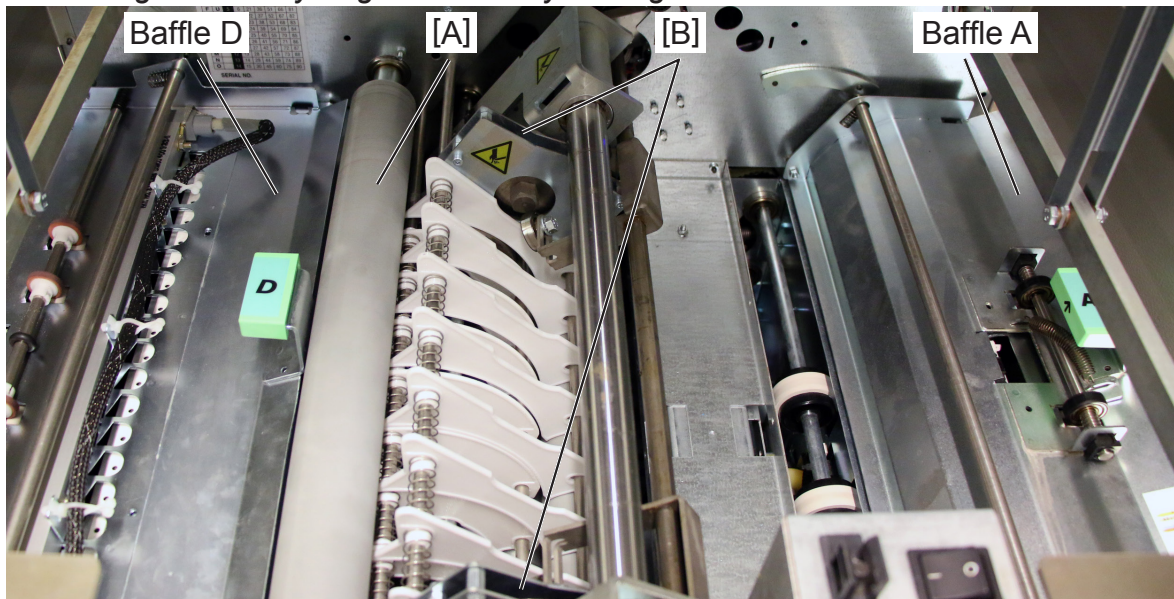

Registration and creaser area

- 1 Open the slide door [A].
- 2 Unlatch and pull out the slide [B].
- 3 Open “B” [C] and “C” [D] baffles if needed.
- 4 Remove any misfeed(s).
- 5 Push in and latch the slide.
- 6 Always remove any residual waste from waste channel and waste [C] belt before closing the slide door.
- 7 Close the slide door.

Clearing jams in the waste transport

The waste transport is easily accessible through the slide door. Shreds jammed in or wrapped around the knife assembly are also accessible through the slide door.

5

⚠ CAUTION:

Under no circumstances should jams around the trimmer blades be cleared using metallic tools. The edges are very fragile and easily damaged.

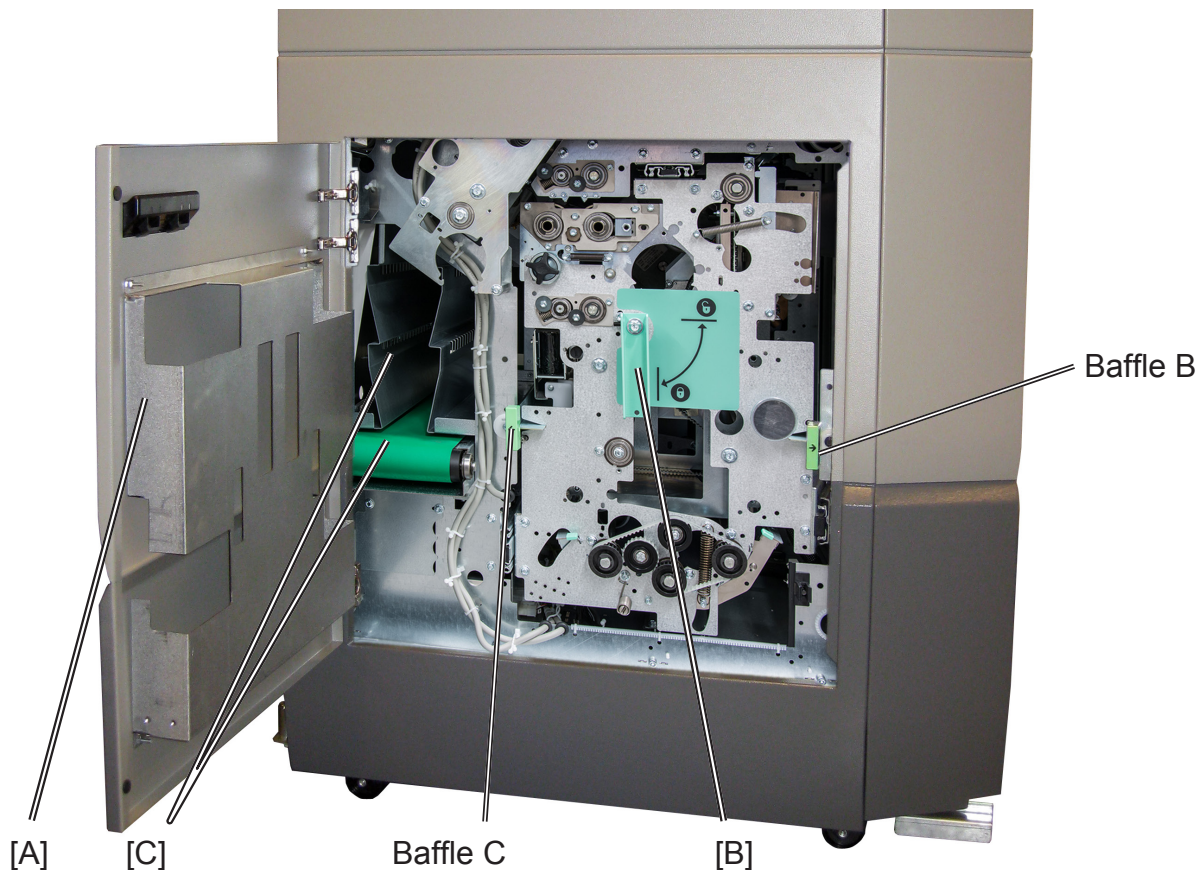

Booklet Maker

Clearing misfeed(s)

Inside the Booklet Maker

5

Attention!

 Paper misfeed detected at the following points, please clear the paper path.
Area B1: BK-201, Clear misfeed!

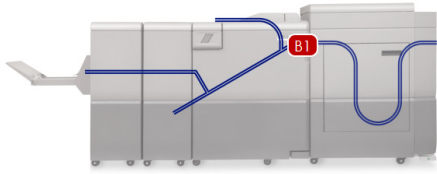

To clear a misfeed indicated in Area B1

- 1 Open the top cover.
- 2 Remove misfed sheets.
- 3 Close the top cover.

Attention!

 Paper misfeed detected at the following points, please clear the paper path.
Area B2: BK-204, Clear misfeed!

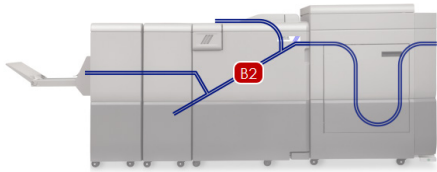

To clear a misfeed indicated in Area B2

- 1 Open the top cover.
- 2 Close top cover.

If system does not purge, open top cover and remove misfed sheets manually.

Attention!

 Paper misfeed detected at the following points, please clear the paper path.
Area B3: BK-207, Clear misfeed!

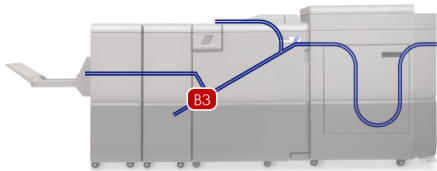

To clear a misfeed indicated in Area B3

- 1 Open the top cover.
- 2 Close top cover.

If misfeed condition remains:

- 1 Switch off the main power.
- 2 Switch on the main power.

Clearing misfeed(s), continued

Clearing misfeed in folder area

- 1 Open Top Cover.
- 2 Open the fold roller paper guide [A] by pushing (arrow 1), lifting (arrow 2) and pivoting (arrow 3) to access any misfed or jammed sheets/booklets between the lower and upper pair of fold rollers.
- 3 Remove sheets/booklets in folder area between fold rollers.
- 4 In reversed manner, place the fold roller paper guide back in operating position.

 **NOTE:**

Make sure the fold roller paper guide is locked in operating position [B] at both sides.

- 5 Close Top Cover.

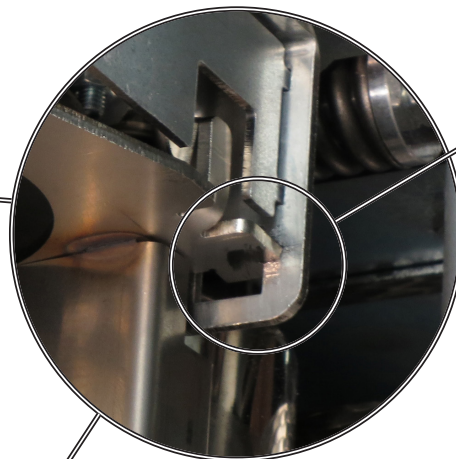
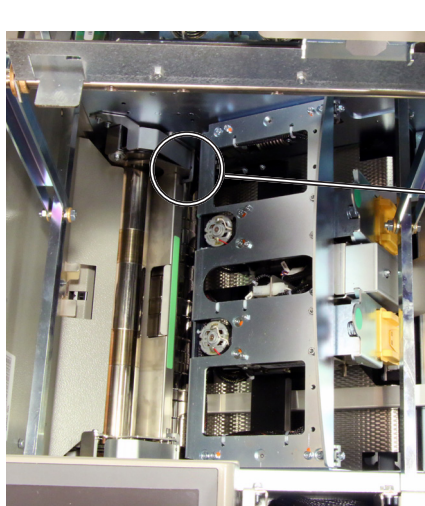
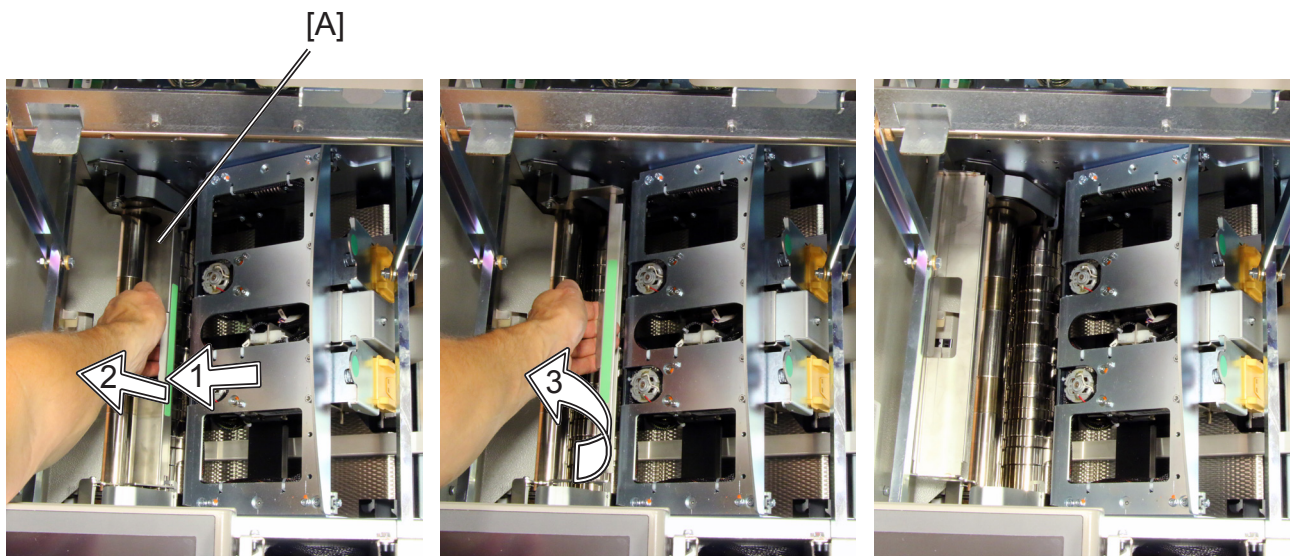

*Fold roller
paper guide
locks here*

[B]

Cover Feeder

Clearing misfeed(s) in vertical transport area

- 1** Open the Top Cover [A].
- 2** Lift the jam clearance baffle [B].
- 3** Remove the misfed sheet.
- 4** Put the jam clearance baffle back in normal position.

5



BookFold Module

Clearing misfeed(s)

Inside the BookFold Module

- 1 Open the top cover.
- 2 Lift up upper feed belts (A) to access jammed/misfed booklets.

 **NOTE:**

Press the green dots (B) (only one visible in picture) on the latches to release.

- 3 Remove the jammed/misfed booklets.
- 4 Place the upper feed belts in normal position.
- 5 Close the top cover.

5

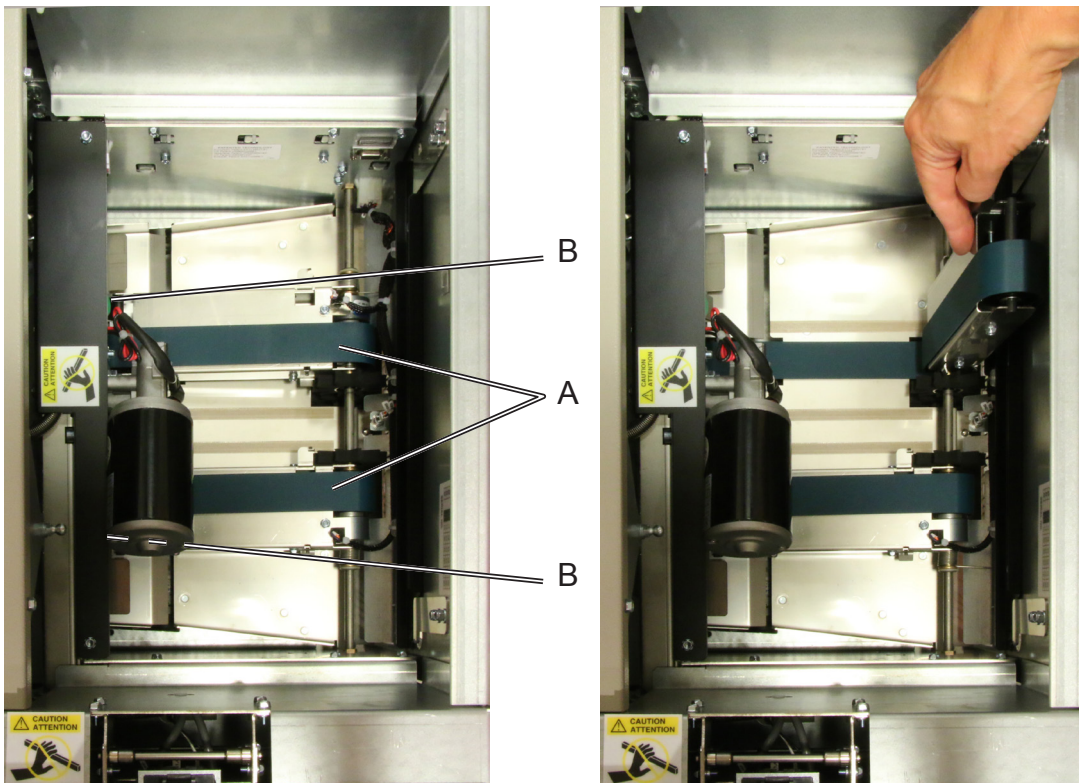

 **NOTE:**

The upper feed belt on the operator side sided cannot be lifted fully.

Trimmer

Clearing misfeed(s)

The upper trimmer blade on the trimmer is protected by a knife protection plate that moves away during the cutting stroke.

⚠ WARNING:

Never put fingers or other parts of the body between the upper and lower trimmer knives.

Clearing misfeed in input area

5

- 1 Raise the rightmost side of the infeed roller shaft assembly (A).
- 2 Remove the misfed sheets in the infeed area.
- 3 After the misfed sheets are removed, place the infeed roller shaft assembly into operating position.

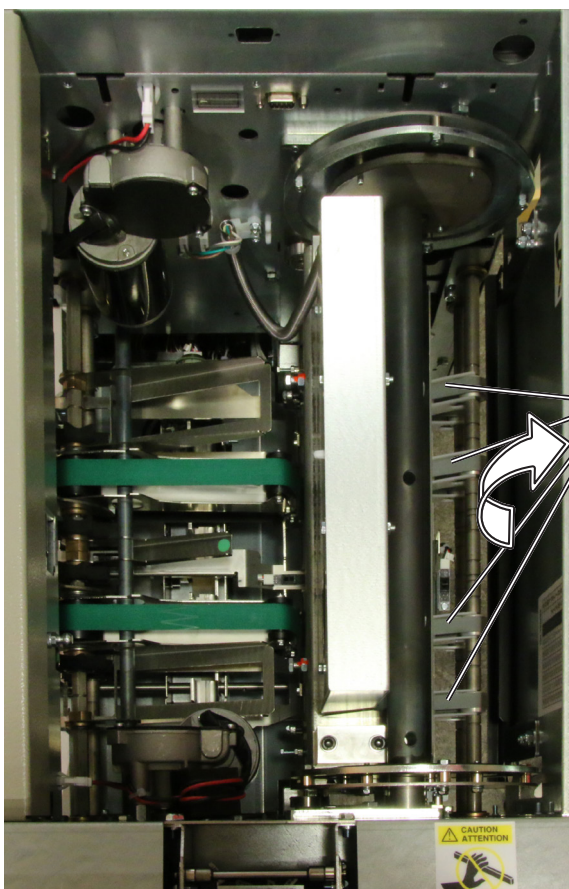

infeed roller shaft assy. in normal position

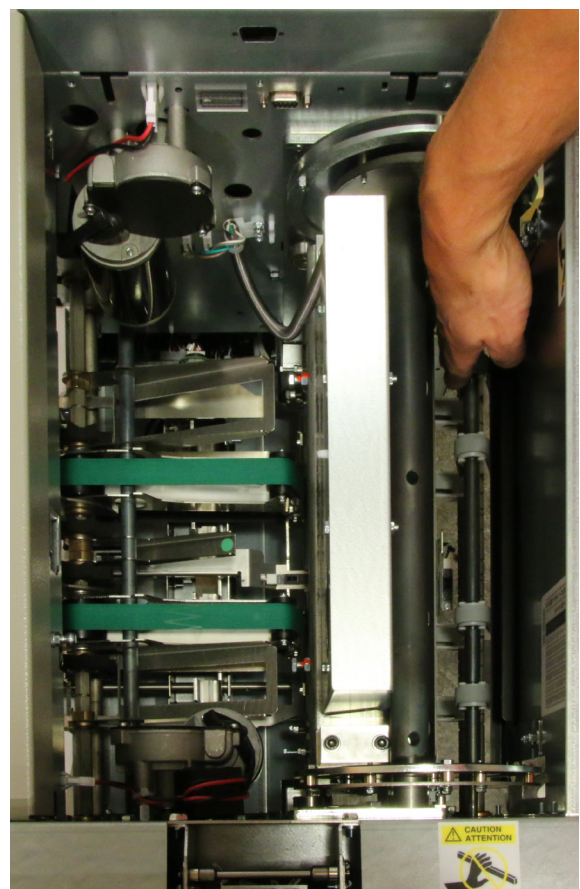

infeed roller shaft assy. lifted

Clearing misfeed(s), continued

Clearing misfeed in exit area

- 1** Lift the exit compressing brackets and transport belts [B].
- 2** Secure using the latch [C]. Not clearly visible in picture
- 3** Remove the misfed sheets from the exit area.
- 4** After the misfed sheets are removed, release the latch [C] and place the exit compressing brackets in operating position.

5

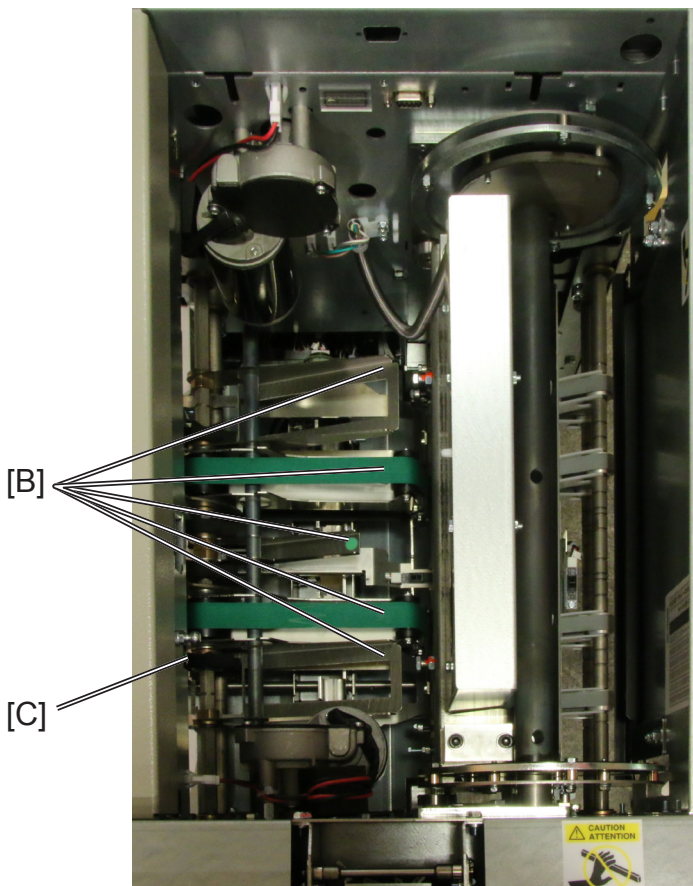

Exit compressing brackets in normal position

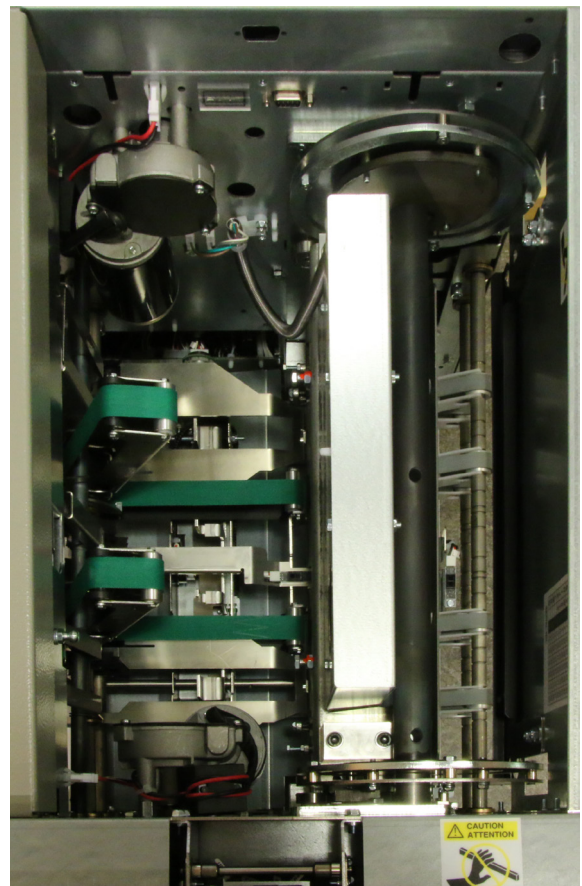

Exit compressing brackets lifted

Belt stacker

Clearing misfeed(s)

Clearing misfeed on belt stacker

- 1** Lift the belt stacker exit cover (A).
- 2** Remove jammed/misfed booklets.
- 3** Place belt stacker exit cover back in operating position.

5

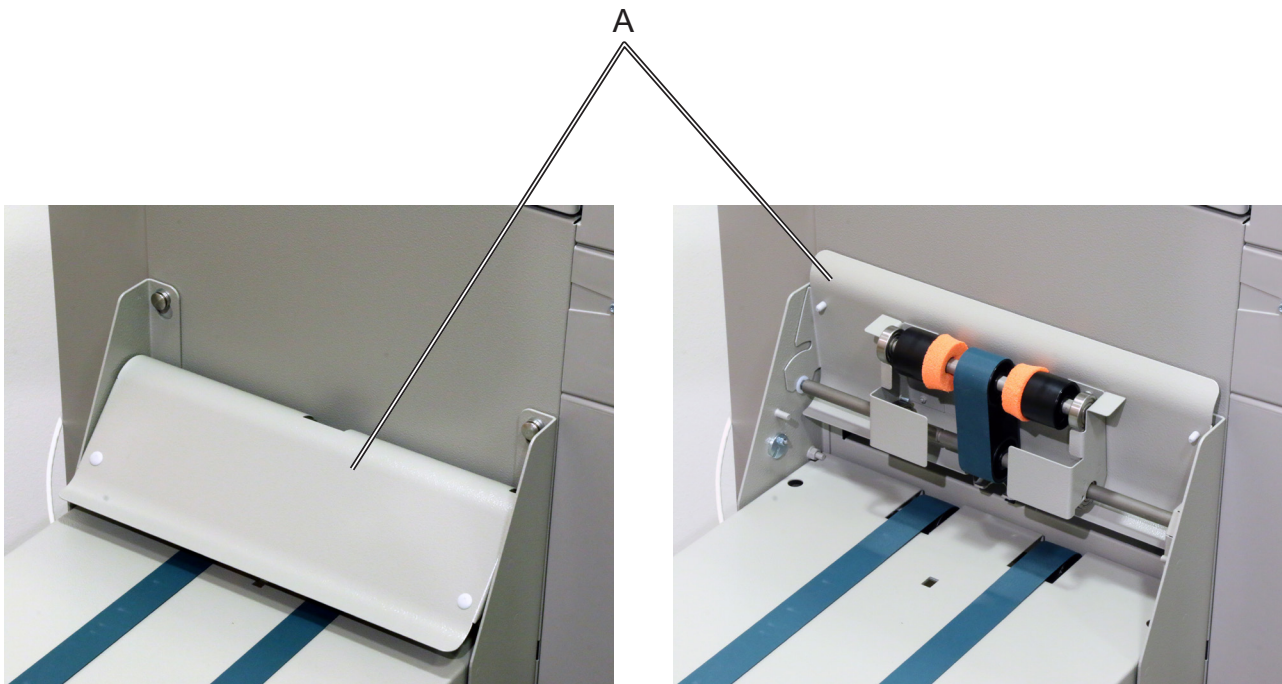

6. Troubleshooting

Fault codes

General

When there is a misfeed or fault condition in the Booklet Maker system, a code and/or a message will be displayed on the UI. Table and fault code descriptions below will guide you troubleshooting.

If frequent input jams are experienced please check paper curl and de-curler adjustments in printer operator guide.

For fault codes other than specified below - remove any paper in the paper path and power Off and On the system.

 **NOTE:**

If procedures in this manual do not rectify the problem an authorized technician will be needed.

RCT fault codes

RCT

Code / message	Explanation / action
RCT-001 - RCT-171 Possible fault in area, please power off and power on to recover!	Indicates that there might be an internal communication error between the RCT module and the Booklet Maker. Check that the RCT is powered up and that the communication cable between the RCT module and the Booklet Maker is OK. Power off and on the system. If problem persists, contact customer support.
RCT201 - RCT212 Clear misfeed!	A misfeed has occurred either in the RCT module. See section 5, "Clearing Misfeed(s)" for how to clear misfeed(s). If feed errors occurs in the paper path or in the waste transport system, check for obstructions. If no obvious obstructions are found, see section 7, "REMARKS" Maintaining Your Machine.
Empty trim bin from RCT module and check waste belt!	Check / Empty Waste container and check Waste Transport for buildup of trim waste strips. It is highly recommended to empty the waste box whenever the system stops to keep up productivity.

Booklet Maker fault codes

Booklet Maker

Code / message	Explanation / action
BK-001 - BK-169 Possible fault in area, please power off and power on to recover!	Indicates that there might be an internal communication error. Power off and on the system. If problem persists, contact customer support.
BK-170, Incompatible RCT software!	Software in the RCT is reported to be of an incompatible version. Power off and on the system. If problem persists, contact customer support.
BK-201 - BK-208 Clear misfeed!	A misfeed has occurred in the Booklet maker. See section 5, "Clearing Misfeed(s)" for how to clear misfeed(s).
BK-401, Check right stapler! BK-402, Check left stapler! BK-403, Check right and left stapler!	Indicates jam in either or both staplers. Check staple cartridge(s) according to procedure in section 1, "Basics."
BK-404, Set too thick, remove set from booklet maker!	Indicates that the set from the copier is outside Booklet Maker specifications and is too thick to be folded. Open top cover and remove set. Close top cover.
BK-407 Too many sheets, remove set and reduce number of sheets in the job!	Indicating there are too many sheets in the Booklet Maker. Open top cover and remove set. Close top cover. Reduce the number of sheets in the job.
BK-408 CF empty, remove incomplete set from Booklet Maker!	Using the Cover Feeder as a regular feeder, the bin has run out of sheets before a set was completed. Open top cover and remove the incomplete set from the Booklet Maker.
BK-600 - BK-615 File error!	Indicates that there might be an internal communication error. Power off and on the system. If problem persists, contact customer support.
Replace right staple cartridge! Replace left staple cartridge! Replace right and left staple cartridges!	Indicates almost out of staples in either or both staplers. Change staple cartridge(s) according to procedure in section 1, "Basics."
Process speed is too high, check setting "Set sheet count"! Incomplete set was delivered to the stacker!	Press the [Fix now] button and set the correct number of sheets per set.
Warning for low productivity! Check setting "Set sheet count"!	Press the [Fix now] button and set the correct number of sheets per set.
Remove purged cover from inside booklet maker!	There is a purged cover inside the Booklet Maker. Open top cover and remove set. Close top cover.
Size mismatch! Hold the job in the printer and check paper size settings.	There is a mismatch between paper size in the printer and the Booklet Maker. Input sheet size in the Booklet Maker is automatically set to AUTO. Press the [Done] button to continue with the Booklet Maker in AUTO mode or hold the printer and a check paper size settings.

Cover Feeder fault codes

Cover Feeder

Code / message	Explanation / action
CF-001 - CF-012 Possible fault in area, please power off and power on to recover!	Indicates that there might be an internal communication error. Power off and on the system. If problem persists, contact customer support.
CF-201 Out of covers, remove sheets from Booklet Maker!	Indicates "Out of covers" in the Cover Feeder. Load covers according to section 1, "Basics."
CF-202 - CF205 and CF-207 Clear misfeed!	A misfeed has occurred in the Cover Feeder. Check cover loading according to section 1, "Basics", Cover Feeder. If problem persists, clean separator pad according to section 7, "REMARKS."
Double feed from CF, remove double from inside the booklet maker.	<p>A double feed has occurred in the Cover Feeder. If there was a true double:</p> <ol style="list-style-type: none"> 1. Check for proper loading of covers according to section 1, "Basics", Cover Feeder. 2. Increase air flow according to section 2, "Making Booklets." 3. Clean feed belts according to section 7, "REMARKS", Maintaining your machines. <p>If there is a false double:</p> <ol style="list-style-type: none"> 1. Check that covers are within specification. 2. Temporary turn double sheet detection off. See section 2, "Making Booklets", Customizing settings. <p>If the covers fed are thick, with dark print or with mixed prints on the covers, double feeding may be displayed even if that is not the case.</p>
Cover size not equal to paper size. Change cover size!	<p>Indicates that there is a format mismatch between the sheets loaded in the Cover Feeder and the sheets in the Booklet Maker.</p> <p>There are two options:</p> <ol style="list-style-type: none"> 1. Correct either mismatch and press the [Done] button. 2. Turn the Cover Feeder off by pressing the [Turn cover off] button to continue booklet making but without feeding covers.

Cover Feeder fault codes, continues

Cover Feeder, continues

Code / message	Explanation / action
Cover stack is low, please add covers!	<p>Indicates that the Cover Feeder is almost out of Covers. There are two ways to continue operation.</p> <ol style="list-style-type: none"> 1. Loading more cover sheets: Load more cover sheets according to section 2, "Making Booklets" and press the [Done] button. The message will extinguish and copier will start. 2. Using up the remaining cover sheets that are loaded: Press the [Dismiss] button. The message will extinguish and copier will start. <p> NOTE: <i>Be aware that if you use alternative 2, the system will hard stop i.e. without completing the cycle when there is no covers left.</i></p>
Load covers!	<p>Message is displayed when covers are empty. Message will also be displayed if the green [check] button was pressed after deciding to use Covers or Protection sheets, but before the bin was loaded.</p> <p>There are two ways to continue operation.</p> <ol style="list-style-type: none"> 1. If you wish to continue production: Load cover sheets according to section 2, "Making Booklets." and press the [Done] button. The message will extinguish and copier will start. 2. If cover job is finished and you wish to run a new job without covers: Select Cover Off in the Cover menu.

6

BookFold Module fault codes

BookFold Module

Code / message	Explanation / action
BF-001 - BF-151 Possible fault in area, please power off and power on to recover!	Indicates that there might be an internal communication error. Power off and on the system. If problem persists, contact customer support.
BF-201 - BF-206 Clear misfeed	<p>A misfeed has occurred in the BookFold Module. If problem persists, clean feed belts according to section 7, "REMARKS."</p> <p>Check that the pressure on the upper feed belts is set to the default position. The pressure springs should always be at its upper position where the pressure is equal to its highest value. See section 7, "REMARKS."</p>

Trimmer fault codes

Trimmer	
Code / message	Explanation / action
TR-001 - TR-153 Possible fault in area, please power off and power on to recover!	Indicates that there might be an internal communication error. Power off and on the system. If problem persists, contact customer support.
TR-201 - TR-206 Clear misfeed	A misfeed has occurred in the Trimmer. See section 5, "Clearing Misfeed(s)" for how to clear misfeed(s).
Empty trim waste bin from Face Trimmer!	Indicates that the trim bin is full or that a trim strip, due to static electricity, is prevented from falling down into the trim bin. Empty the trim bin and remove loose trim strips from inside the Trimmer. See section 1, "Basics." for how to remove the trim bin.
Close infeed belts!	Indicates that the infeed roller shaft assy. is lifted. Close it. See section 5, "Clearing Misfeed(s)."
Close exit belts!	Indicates that the exit compressing brackets are lifted. Close them. See section 5, "Clearing Misfeed(s)."
Close infeed and exit belts!	Indicates that the infeed roller shaft assy. and the exit compressing brackets are lifted. Close them. See section 5, "Clearing Misfeed(s)."

 **NOTE:**

During poor environmental conditions waste from the trimming operation may be transported through the system.

To improve the situation, the trim margin may be increased and thereby ensuring that the waste is transported into the waste bin.

Belt stacker fault codes

Belt stacker	
Code / message	Explanation / action
Stacker full, please empty stacker!	Stacker is full. Empty stacker.

General fault codes

Clear Misfeed(s)

Attention!

 Paper misfeed detected at the following points, please clear the paper path.
Area B1: BK-202. Clear misfeed!

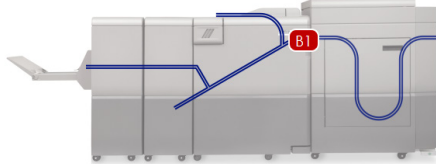

In general, fault codes indicate a misfeed condition. When a misfeed occurs, a code, the message “Clear misfeed(s)” and the jam area will be displayed. See section 5, “Clearing Misfeeds”, for how to clear a misfeed.

Close cover(s)

Close covers!

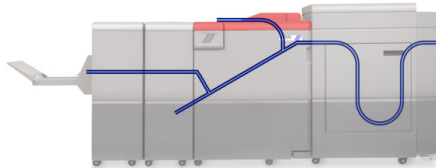

When the message “Close Cover(s)” is displayed any of the interlock switches are actuated.

- 1** Check that the top cover is in down position.
- 2** Make sure that the cover of the Belt Stacker is in normal position, see section 5, “Clearing Misfeeds”, Belt stacker.
- 3** Make sure power cables between Booklet Maker, BookFold Module and Trimmer are connected

Empty stacker!

Attention!

Area D: Stacker full, Please Empty stacker!

Done

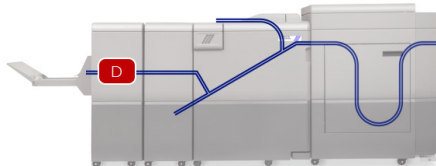

This message will be displayed when the stacker is full. Empty the belt stacker and press the [Done] button to continue operation.

7. REMARKS

Do's And Don'ts

- Always follow all warnings marked on, or supplied with, the equipment.
- Always exercise care in moving or relocating the equipment.
-  **CAUTION:**
Unplug the power cord from the wall outlet and machine before you move or relocate the equipment.
- Do not remove the covers or guards that are fastened with screws.
- Do not override or bypass electrical or mechanical interlock devices.
- Do not operate the equipment if you notice unusual noises or odors. Disconnect the power cord from the power source and call your authorized technician to correct the problem.

 **WARNING:**
Do not put fingers or other parts of the body between the upper and lower trimmer knives.

- Do not switch off the main power switch while machine is running. Make sure machine cycle has ended.
- Do not open covers while machine is running.
- Do not move machine while machine is running.

Where to put Your Machine

Machine environment

- **Always** locate the equipment on a solid support surface with adequate strength for the weight of the machine.
- Always keep magnets and all devices with strong magnetic fields away from the machine.

If the place of installation is air-conditioned or heated, do not place the machine where it will be:

- Subjected to sudden temperature changes.
- Directly exposed to cool air from air-conditioner.
- Directly exposed to heat from heater.
- Directly exposed to sunlight.

7

Power connection

- **Always** connect the equipment to a properly grounded power source. If in doubt, have the power source checked by a qualified electrician.
-  **WARNING:**
Improper grounding of the equipment can result in electrical shock.
- **Never** connect the machine to a power source that lacks a ground connection terminal.

Access to machine

Place the machine near the power source, providing clearance as shown.

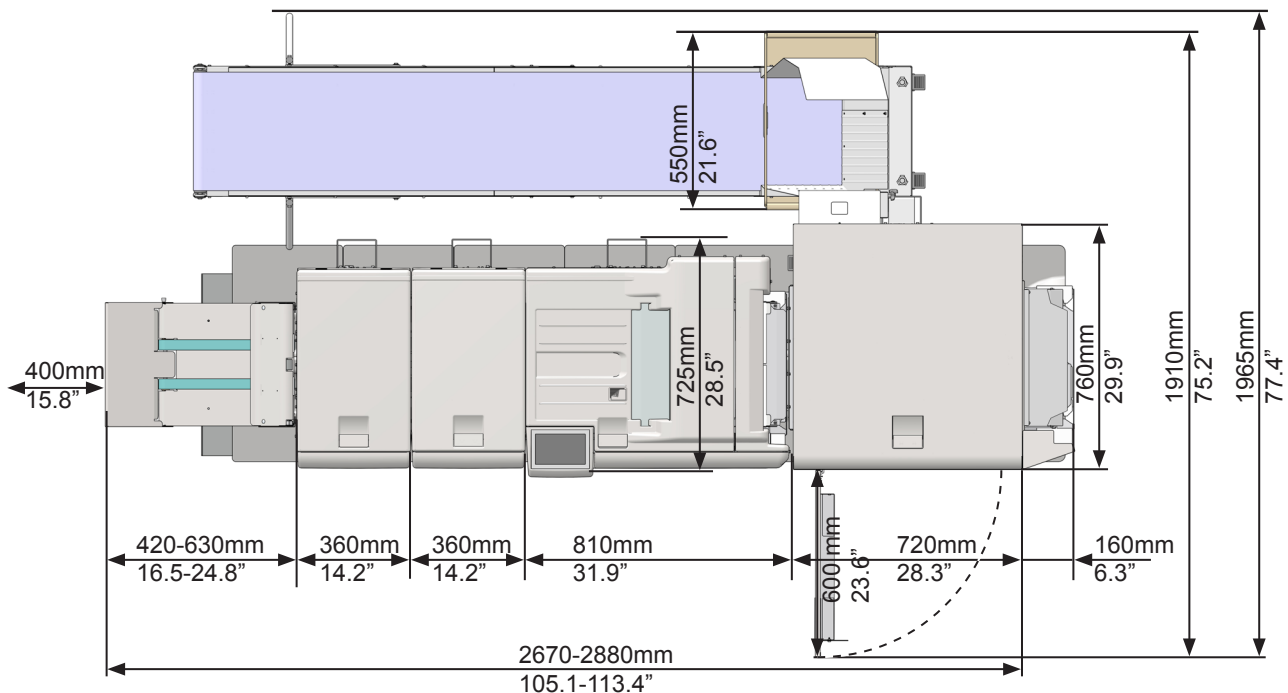

7

Ensure that the minimum required floor space is available for the system that you are about to install (Figure 1).

The optional high capacity Belt Stacker BST4000-1 can be placed either in-line or angled to the Booklet Making system.

The BST4000-1 measures 1730x440mm / 68x17”.

Approximate floor space requirements / configuration;

- PBM350e/500e + Stacker ~1440mm / 57”.
- PBM350e/500e +PBM TR + Stacker ~ 1800mm / 71”.
- PBM350e/500e + PBM BF + PBM TR + Stacker ~ 2160mm / 85”.
- RCTe + PBM350e/500e + PBM BF + PBM TR + Stacker = 2880mm / 114”.
- RCTe + PBM350e/500e + PBM BF + PBM TR + BST4000-1 Stacker (straight) = 4400mm / 173”.
- RCTe + PBM350e/500e + PBM BF + PBM TR + BST4000-1 Stacker (angled) = 3110mm / 122”.

NOTE:

PBM500e Upgrade kit and Plockmatic Cover Feeder does not impact floor space requirements.

Maintaining Your Machines

Never attempt any maintenance function that is not specifically described in this documentation.

Cover Feeder

Cleaning feed rollers and paper separator pad

The Feed rollers need to be cleaned regularly when in use, and if the unit has not been used for a period of time. How often this should be done, depends on the paper type and print quality.

An increasing number of misfeeds, or double feeds, is one indication of the need to clean the Feed Rollers.

- 1** Remove the feed roller assembly by pressing it to the front of unit (A). The non operator side end of the feed roller assembly will now be released (B) and the assembly can be removed.
- 2** Clean the Feed rollers and the Paper separator pad with water and a clean lint free cloth.

7

Press toward front.

Lift out this side

Paper separator pad

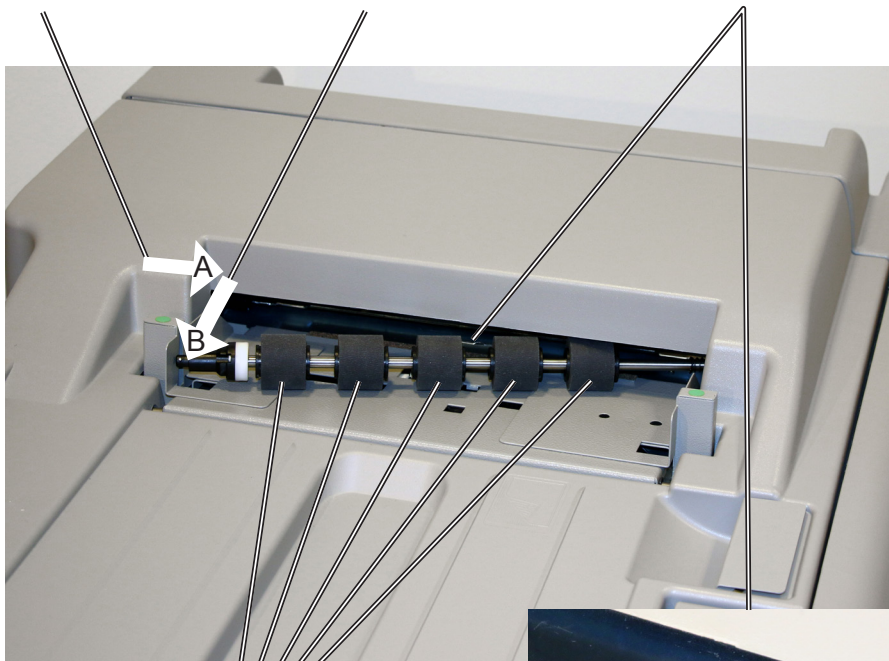

Feed rollers

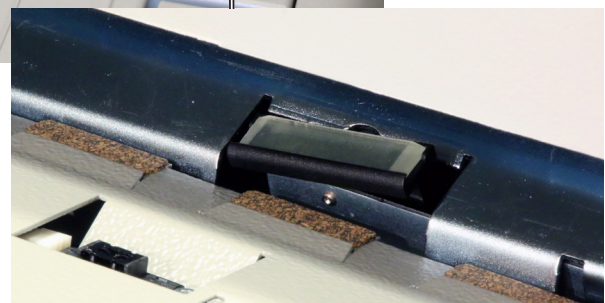

BookFold Module

Cleaning feed belts

The Feed belts need to be cleaned regularly when in use, and if the unit has not been used for a period of time. How often this should be done, depends on the paper type and print quality.

An increasing number of misfeeds is one indication of the need to clean the feed belts. Clean the feed belts with water and a lint free cloth.

- 1** Open the top cover.
- 2** Clean the upper feed belts (A). The upper feed belts can easily be rotated in either direction.
- 3** Press the release latch (B), one to each and lift up the upper feed belts to access the lower feed belts.
- 4** Clean the lower feed belts (C). Rotate the lower feed belts towards the exit side for complete cleaning.
- 5** Place the upper feed belts in normal position.
- 6** Close the top cover.

7

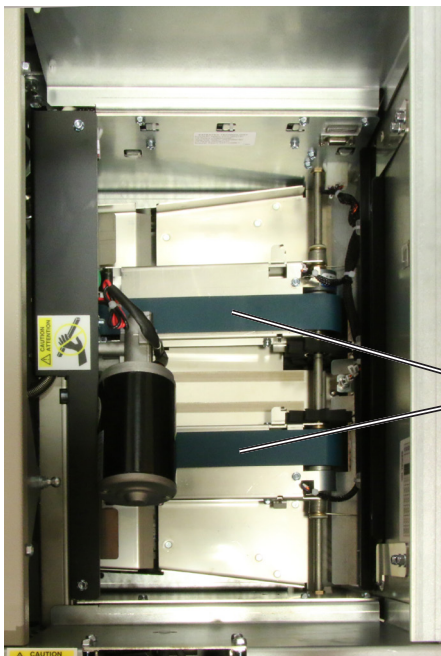

Upper feed belts in normal position.

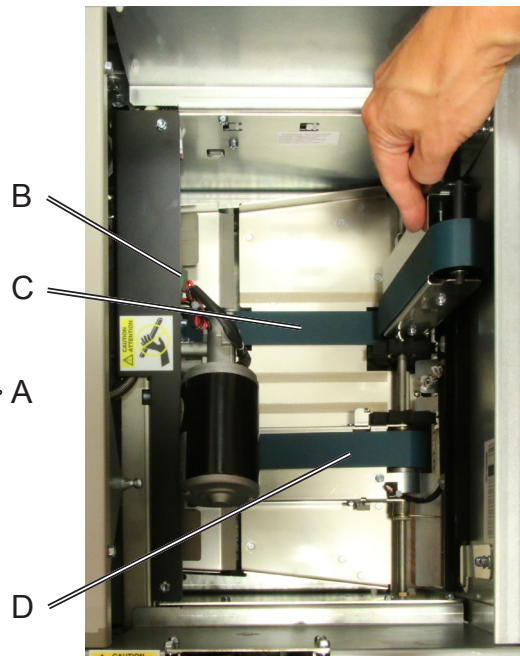

Upper non operator side feed belt lifted up.



NOTE:

The upper feed belt on the operator side side (D) cannot be lifted fully.

BookFold Module, continues

Pressure springs

If feed errors occur, check that the pressure on the upper feed belts is set to the default position. The pressure springs should always be at its upper position where the pressure is equal to its highest value.

Non operator side spring in upper position (default position)



operator side spring in lower position

RCT Module

The feed rollers and paper path need to be cleaned regularly when in use, and if the unit has not been used for a period of time. How often this should be done depends on the paper type and print quality.

An increasing number of misfeeds is one indication of the need to clean the feed roller, paper path and/or the sensors. Feed rollers and paper path are cleaned with the same cleaning agent used to clean the printer and a lint free cloth. Sensors are wiped clean with a lint free cloth.

A problem with registration accuracy is often related to build up residual toner and paper dust.

⚠ CAUTION:

Never use any cleaning fluids on sensors.



⚠ CAUTION

To avoid the Upper Shift Tray from obstructing the RCT Top Cover, make sure the upper Shift Tray is in the upright position before opening the RCT Top Cover. See “Docking the Booklet Maker” in section 1, “Basics”.

Cleaning the paper path transportation nip rollers (12x)

7

Also clean the idler rollers

⚠ WARNING:

Do not put your fingers within knife protections.
Doing so may result in injury.

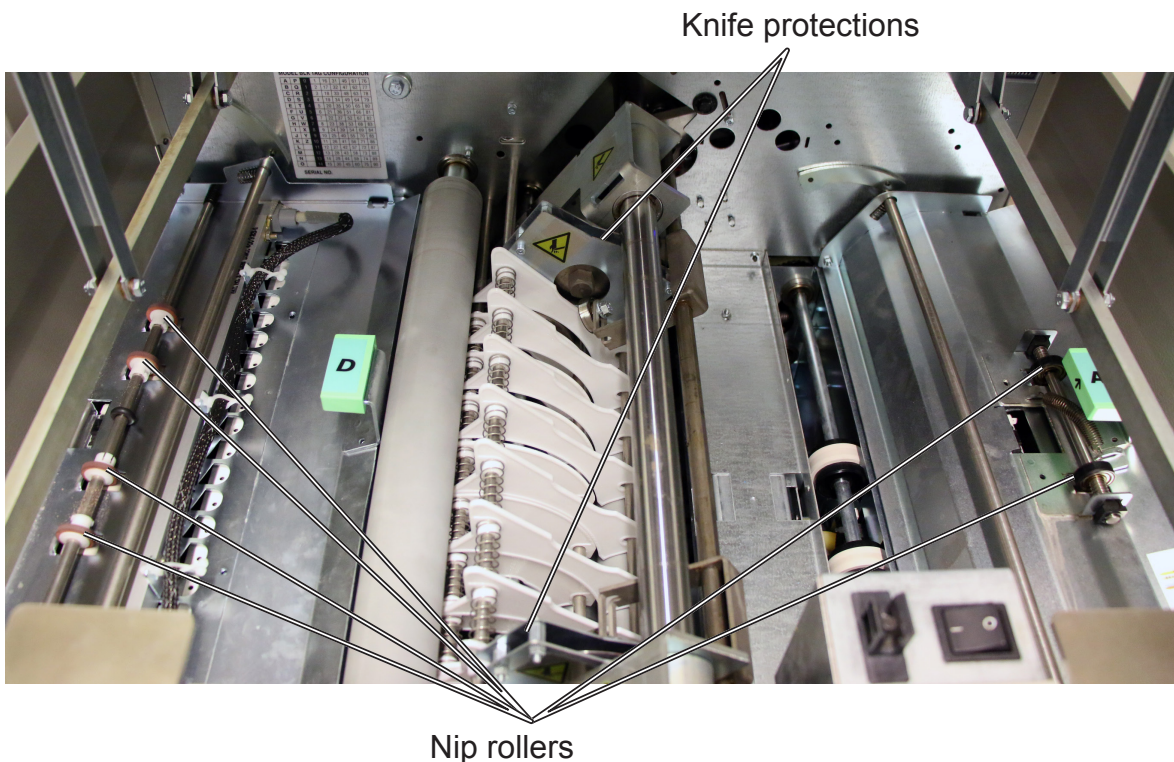

Cleaning the paper path transportation nip rollers (12x) continued

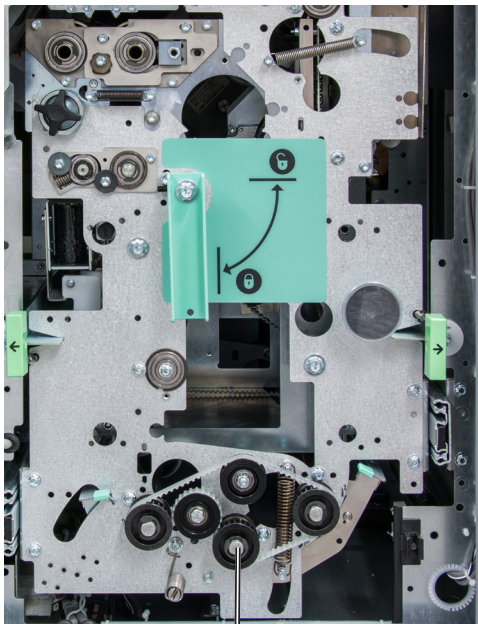

Nip rollers (2x)

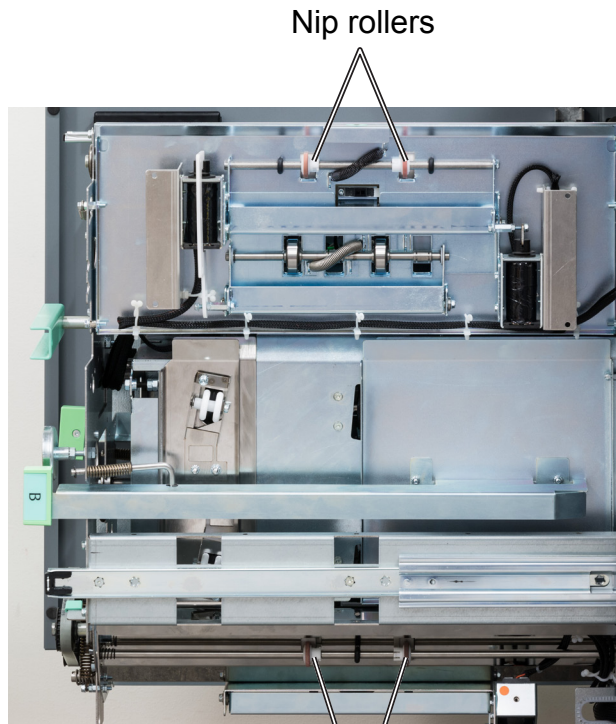

Nip rollers

Nip rollers

7

Cleaning the fixing rollers (3x)

Also clean the idling rollers

⚠ WARNING:
Do not place your fingers inside the knife guards.
Doing so may result in injury.

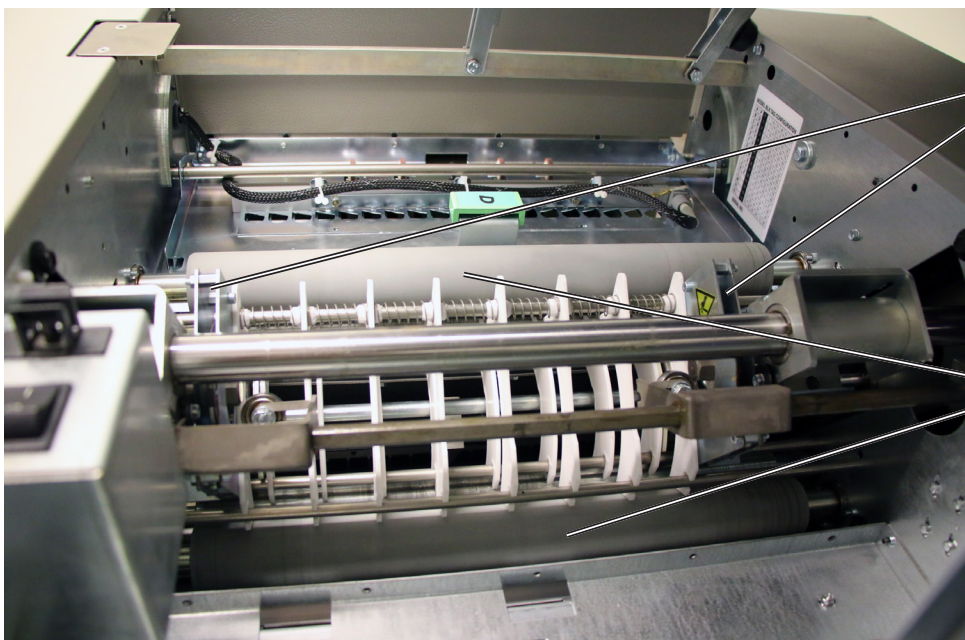

Knife guards

Fixing rollers

continued on next page

Cleaning the fixing rollers (3x) continued

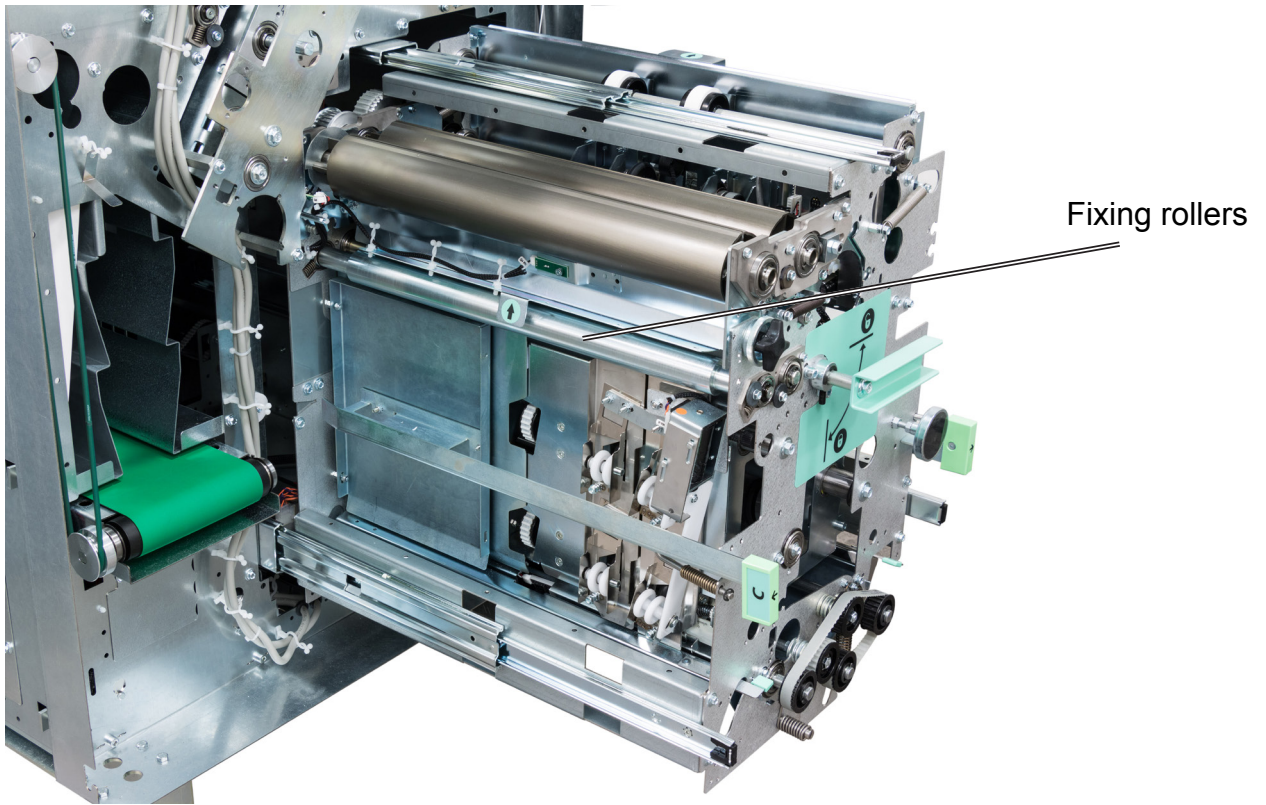

7

Cleaning the registration cross roller (4x) & friction tires (4X)

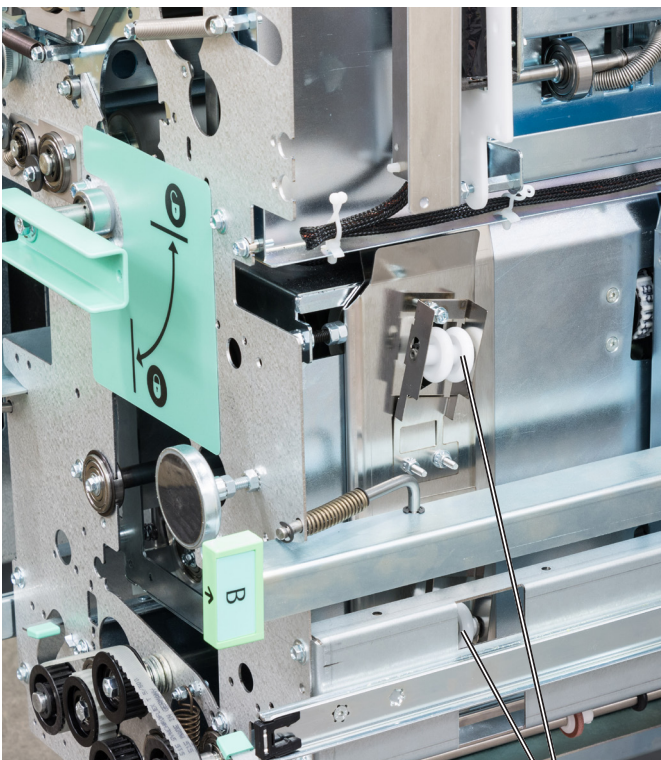

Registration cross rollers

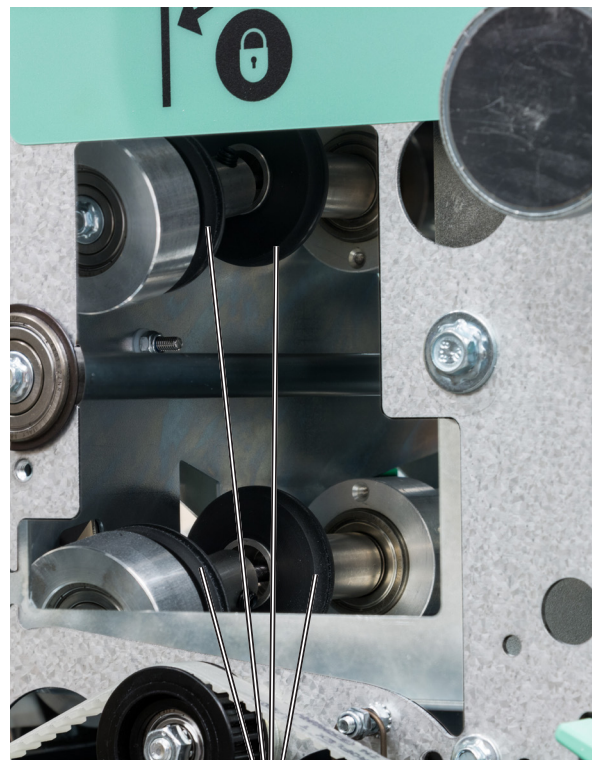

Cleaning friction tires

Cleaning the rotator rollers (2x)

Also clean the idler rollers



Rotator rollers

7

Cleaning the paper path sensors (5x)

⚠ WARNING:
Do not place your fingers inside the knife guards.
Doing so may result in injury.

Infeed sensor

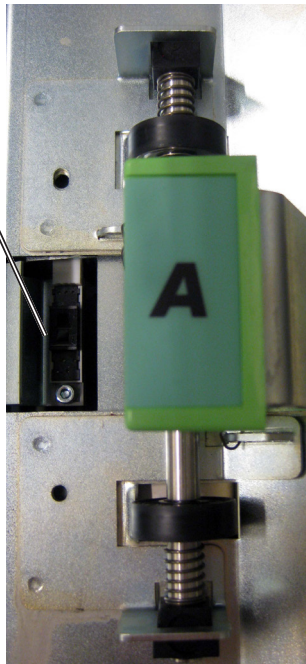

Exit sensor

Knife guards

continued on next page

Cleaning the paper path sensors (5x) continued

Rotator sensor

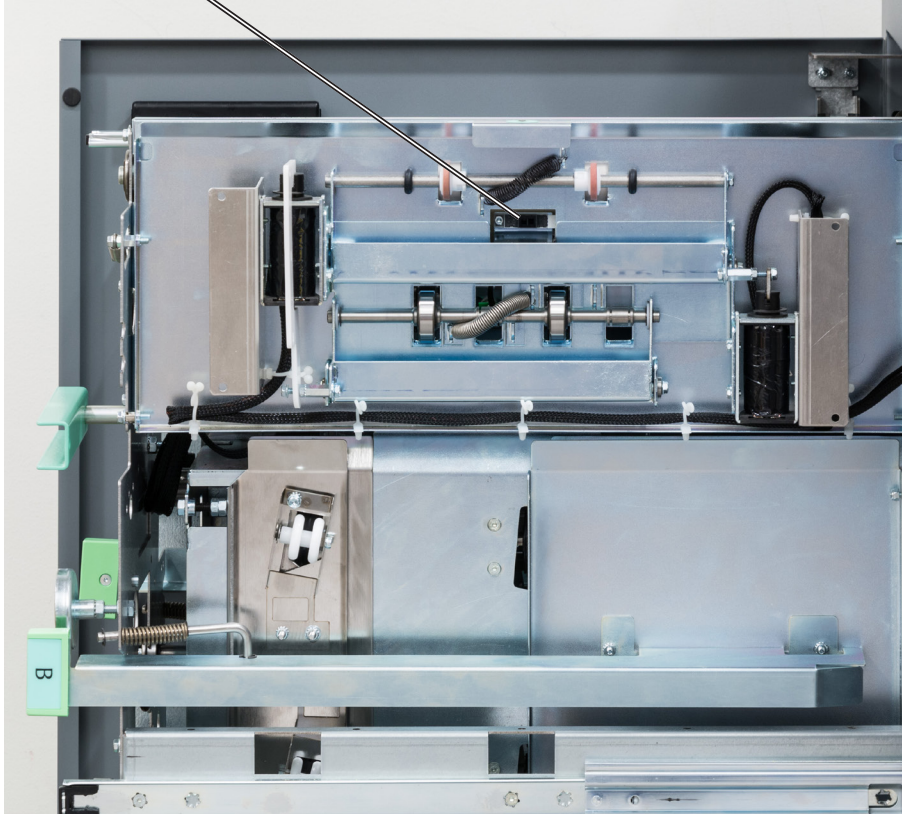

7



Registration sensor

Cleaning the paper path sensors (5x) continued

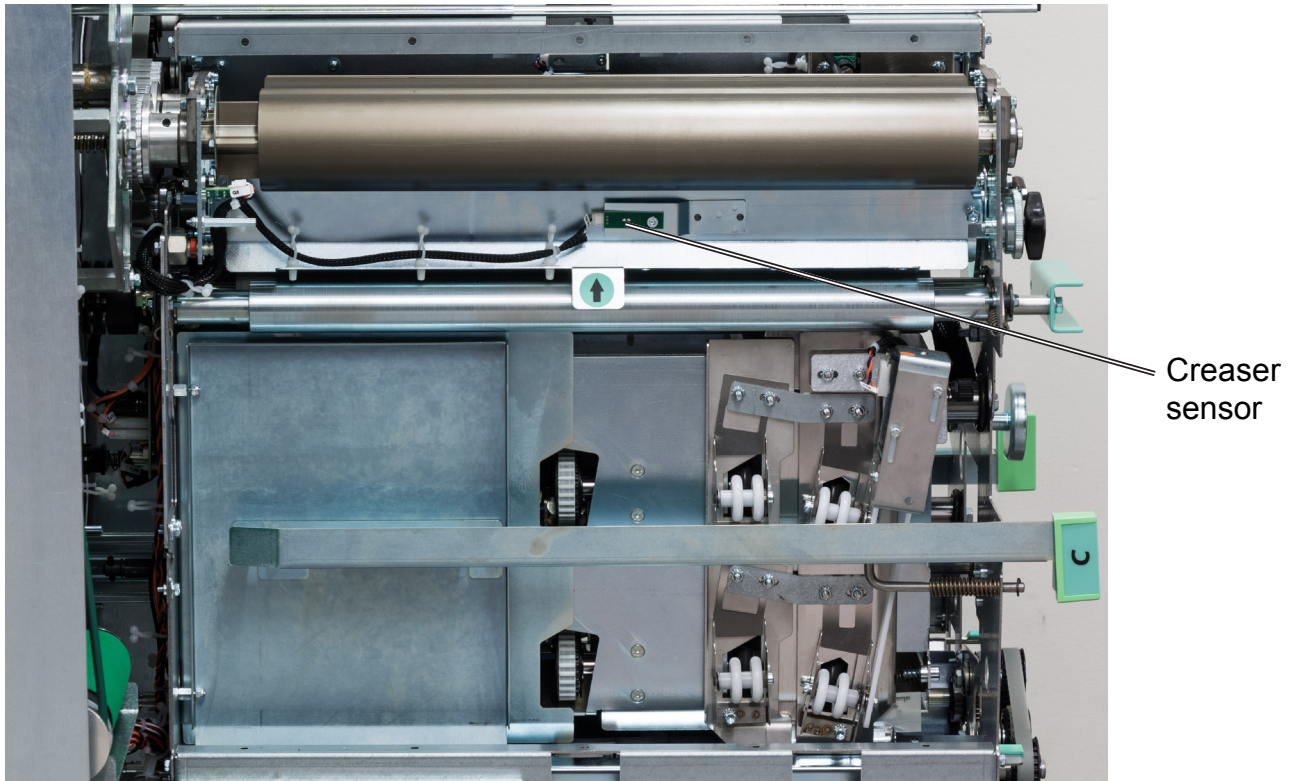

7

Cleaning of creaser tools (2x)

After a period of time toner and paper dust may leave residuals in the grooves of the tool. These grooves must be cleaned periodically to maintain creasing performance.



Adjustment of Bleed Trimmer registration angle (parallel cut)

Adjustment of Bleed Trimmer registration angle (trimmer cut parallel to registration (operator side) edge)

- 1 Turn adjustment screw [A] in desired direction. Change in adjustment is reflected on the reference scale [B].

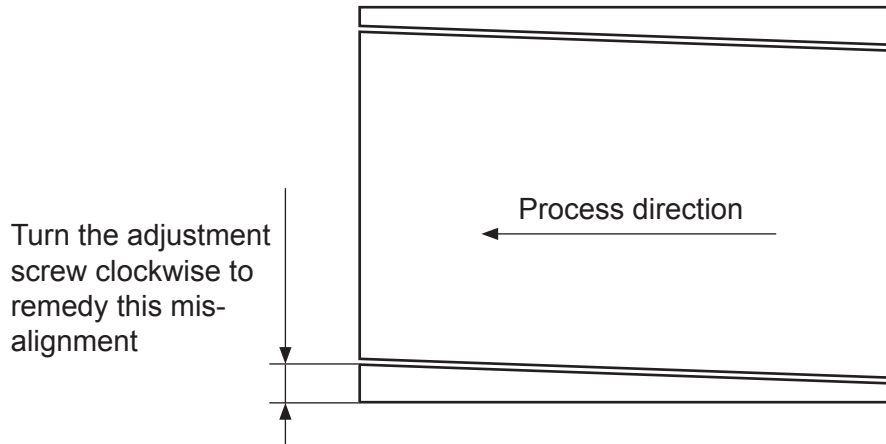

 **NOTE:**

Sheets may show wrinkles in the process direction if adjustment is set too tight. Turn adjustment screw counter clockwise until wrinkles disappear.

7



[A]

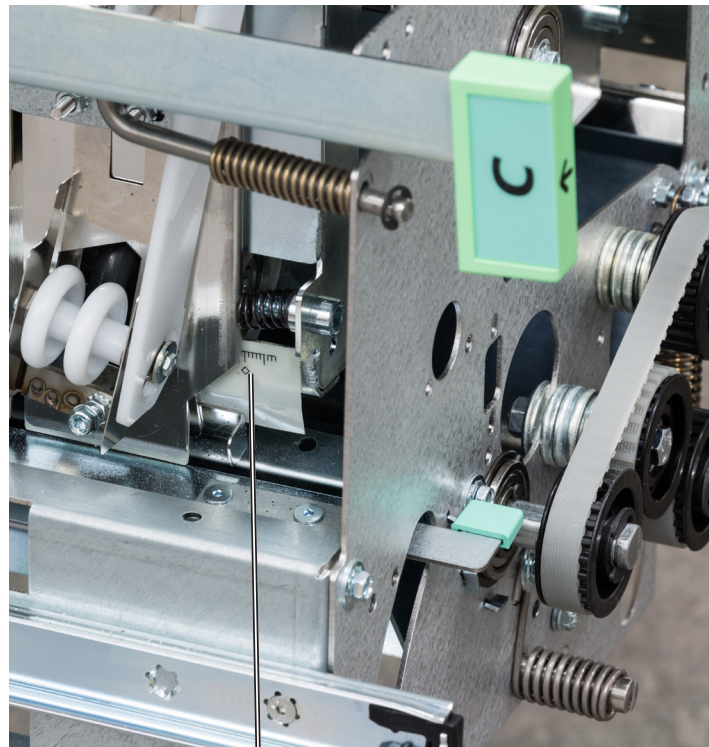

[B]

Adjustment of Creaser registration angle

Adjustment of Creaser registration angle

- 1 Loosen the star shaped knob [A].
- 2 Turn the knurled eccentric adjuster [B] to move reference mark in the desired direction.
- 3 Tighten the star shaped knob [A] again.

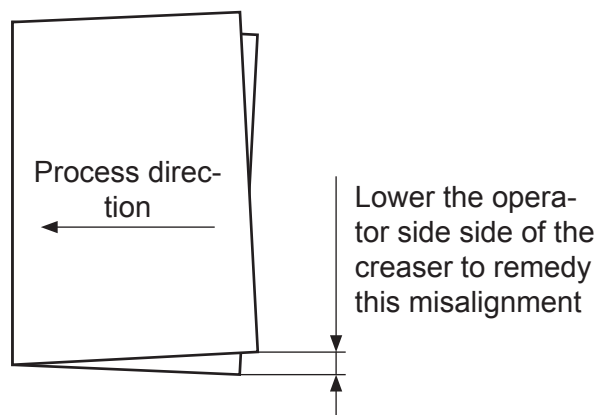

Reference marks

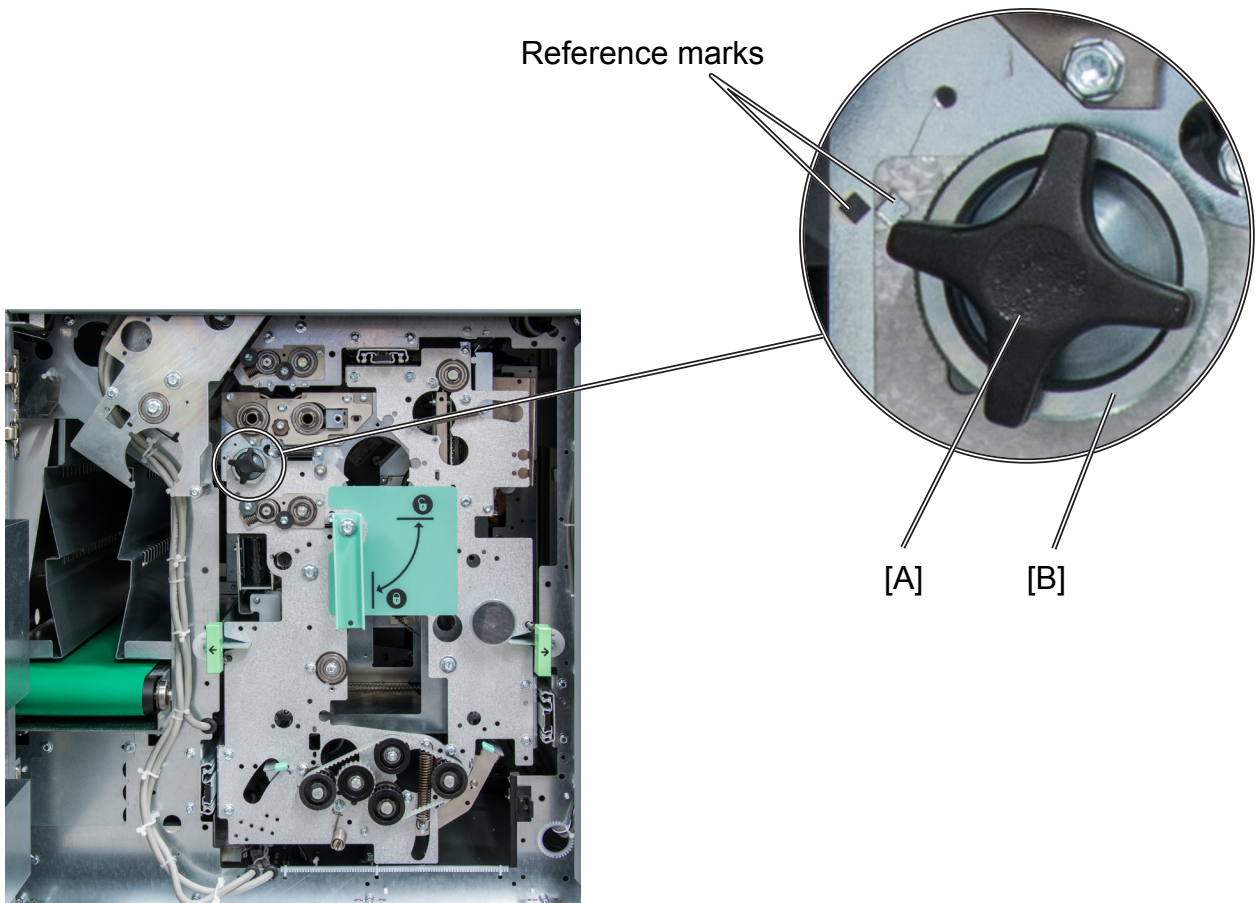

Best practices for the PBM350e/PBM500e system

- If the set is not properly registered (side jogged and back jogged), fine adjustment of registration may improve the situation. See section Fine-tuning booklet appearance for details.
- If staples have problems penetrating thicker sets of heavy media changing staple cartridge may improve the situation.
- If the booklets show markings or scratches the use of the “protection sheet” will improve the situation. See section 2, “Making Booklets”, Customizing settings, Cover, Protection sheet.
- The BookFold module may wrinkle the cover at the spine when light weight media is used for cover sheet. Changing to heavier stock or turning BookFold Module off usually resolves the problem.
- Staple back may be radius shaped (bent) when running with BookFold Module. Moving staple position so staple is centered on the spine will reduce this phenomenon.
- Covers may show marking along the spine of the booklet from the clamp in the BookFold Module. The more pages in the booklet, the more evident the marking. The use of “protection sheet” eliminates this marking.
- For jobs with multiple sheets of 200 gsm or heavier the BookFold Module is recommended for an acceptable output. If a BookFold Module is present in the configuration, it should be turned ON or feed problem at output may occur.
- If the Adjustment of “Bleed Trimmer registration angle” described in section Maintaining Your Machines in the OP manual is set too tight, the sheets may show wrinkles in the process direction.
 - To prevent this phenomenon, turn the adjustment screw counter clockwise until the wrinkles disappear.
- If a JOB is cancelled on the printer there might be an incomplete set inside the PBM System. This set has to be manually removed from the system by opening and closing the Top Cover of the Booklet Maker. This will purge the set.
- Prior to printing, it’s important to make sure that the sheets themselves are square and uniform. If the diagonals are not equal the sheet is not uniform and square and the booklet quality will vary as a result. This problem is more common than you might think!
 - Measure the diagonals of the non-printed sheet.
Both diagonals should measure **exactly** the same length.

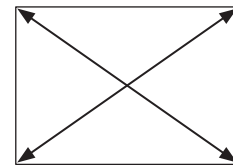

Limitations of the PBM350e/PBM500e system

- The PBM350e/500e Production Booklet Maker systems is suited for customers with a booklet making volume of up to an average of 30,000 booklets per month.
- If sheets entering the PBM350e/PBM500e are not uniform and square the booklet quality will vary accordingly.
- The maximum recommended number of sheets that can be folded without stapling is 2 sheets of 80 gsm. If there is very low friction between the sheets, running non-stapled sets may be difficult.
- Staple position may vary on the spine when being square formed with the BookFold Module, especially on thicker booklets. Moving staple position so staple is centered on the spine will reduce this behavior.
- Staple may be radius shaped (bent) when running with the BookFold Module. Moving staple position so staple is centered on the spine will reduce this.
- Covers may show marking along the spine of the booklet from the clamp in the BookFold Module. The more pages in the booklet, the more evident the marking may be. The use of “protection sheet” eliminates this marking.
- For some white coated stock, such as “Silk type” two-sided coated paper, occasional fold roller marks may be observed on the “top side” of the book. Use of the protection sheet feature eliminates this marking.
- The double feed sensor should be turned off when feeding cover 200 gsm or more from the Cover Feeder. You may also have to turn off this function if you have heavy dark area coverage or covers with different images on them.
- For jobs with multiple sheets of 200 gsm or higher paper stock, the BookFold Module is recommended for best booklet appearance. If a BookFold Module is present in the configuration it shall be turned ON or feed problem at output may occur.
- The protection sheet feature may not function correctly with thicker booklets. If there is very low friction between the protection sheet and the set, functionality may be poor.
- Heavy weight media may show image cracking on the spine. Enable creasing in the RCT module to avoid cracking.
- Thick books made from coated stock with high friction between each sheet may show permanent “wave like” deformation of the sheets.
- Marks from the fold knife may appear on sensitive media on the innermost sheet.
- Marks from side guide motion may appear on sensitive media, the use of protection sheet eliminates this.
- Never run simplex printed sheets from the printer in-line.
- Covers may show markings from the Cover Feeder separation process.
- Small booklets A5/ 5,5 x 8,5” or smaller may stack poorly on the conveyor.
- Sheets may show marks from the RCT “registration rollers”. When observed, changing media to a less glossy finish may improve the condition. The artifact has been observed with, but not necessarily limited to, the following media:
 - OK Top coated: 157 gsm
 - OK Art post: 186.1 gsm
 - Color Copy coated glossy: 135 gsm
 - OK Top coated: 127.9 gsm
 - Cocoon Silk: 250 gsm
 - Mohawk Color Copy Gloss: 216 gsm

Limitations of the PBM350e/PBM500e system, cont.

- OK Art post: 209.4 gsm
- Ricoh my paper: 67 gsm
- If corners/edges of sheets by any reason are folded or highly curled before trimming, result may look as illustrated when corners/edges are unfolded. 
- On some heavy coated media, staples may not completely penetrate the set resulting in a faulty staple. If problem persists, consider changing media. This may occur when close to, or at the designed set size limit. . Some uncoated extra “dense” paper may show the same limitation. The following list shows examples of media where this has been observed:
 - Futura Laser Gloss 80c
 - Hammermil Laser Print
 - OPUS Gloss
 - Mondi Color Copy 200 gsm
 - Sterling Premium Digital Gloss 80T
- On brand new Booklet Maker units, paper may show trace of oil coming from the fold mechanism. Oil is applied to the mechanism during production. The problem will be eliminated after initial production.
- When trimming small amount (less than 5mm or 0.2”) in the PBM Trimmer module on books made from more than 2 sheets, the cut may not be clean, leaving trim waste hanging from the book.
- Paper can show markings on the lead edge of the set from the compiler area. If this occurs the use of the PBM Trimmer module will eliminate this
- For thick booklets, the clinch quality of the staples may show limitations resulting in the staple legs to be spaced away from the sheets.
- Media weights above 250 gsm/14lb Index may show feeding problems in the PBM RCTe module under some conditions. This issue will be more common on smaller sheet sizes A4 and 8,5” x 11”
- Staple leg offset outside the 1,0 mm specification can occur on thicker sets. To check if the unit performs within specification produce a book made from 4 sheets of 80 gsm plain paper.

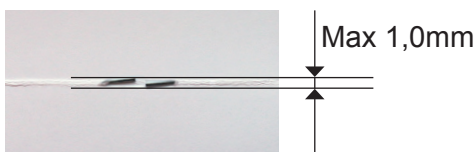

- For thick books with a thin cover, the cover can be “pulled back” during the registration process in the Face Trimmer. This can result in the cover sheet not being trimmed. Recommendation is to use a heavier cover for thick books (over approx. 15 sheets).
- For some media, the legs of the staples may not be properly clinched causing the legs of the staple to be spaced away from the inner sheet. This phenomenon occurs on extra thick books over 40 sheets made from “soft” paper (recycled and some non-coated media mostly). This phenomenon has been observed on:
 - Mondi Color Copy 120 gsm
- The BookFold roller can pick up “colour” from the first staple during the BookFold process. After one full revolution of the BookFold roller, the colour can be smeared off on the spine of the booklet. This phenomenon occurs more for some coated media and for higher BookFold modes.
- The “pressure foot” in the BookFold module can cause a shiny mark on sensitive media. This phenomenon has been observed on Glossy media.

Limitations of the PBM350e/PBM500e system, cont.

- A gray/silver line in the center of the spine can sometimes be observed on booklets. This is caused by the Stop Gate in the Book Fold module.
This phenomenon is worse on some coated media. Changing media will improve.
- Producing booklets in copy mode by scanning the original on the contact glass is not possible.
- Marks around the staple position on the outside of the booklet cover may be caused by dirt deposits underneath or on the staple.
Changing media may improve.
Changing staple cartridge will improve, see section 1, "Basics."
Cleaning staple cartridge will improve, see section 7, "REMARKS."
- Grey marks around the staple area in the center of the booklet may be caused by metal dust from the staple. This phenomenon is worse on matte coated media.
Changing media will improve.
Cleaning the clincher area will improve, see section 7, "REMARKS."
Trying to get the staple more centred inside the book may also improve. To do that, adjust staple position, see section 2, "Making Booklets."
- Grey marks around the staple area on the spine can sometimes be observed when using the BookFold module. This may be caused by dirt deposits underneath or on the staple that are picked up by the BookFold roller during the BookFold process. This phenomenon occurs more for some coated media and for higher BookFold Pressure Settings.
Selecting a lower BookFold pressure setting may improve.
Switching off the BookFold module may improve.
Changing staple cartridge may improve, see section 1, "Basics."
Cleaning staple cartridge may improve, see section 7, "REMARKS."
- Paper orientation must be SEF when feeding sheets from the Ricoh Interposer CI5030.
- An overly strong BookFold setting and a slightly misaligned center sheet will cause wrinkles along the inner sheet spine.
Selecting a lower BookFold setting will reduce this phenomenon.
- For booklets without face trim, the trailing edge of the booklet may be damaged by the drive belts on the stacker.
Plockmatic recommends using face trim or thicker sheets to minimize damage.
- Extra heavy media 300-350 gsm may not rotate correctly in the PBM RCTe module.
As a workaround operator can try to run media in SEF mode. This may help. This phenomenon has been seen on the following media:
 - Reina (A4 348.8gsm)
- On sensitive media Booklet may show marks on the spine from the transport guides after the fold rollers. This phenomenon has been noticed on the following media:
 - Mohawk Fine Paper Gloss 216 gsmTo prevent this from happen Plockmatic recommends the use of the protection sheet. If CF is already used to feed covers changing to another media will improve the situation.
- On rare occasions fold rollers may pick up metal dust from the staple and "smear" this on the cover of the book. If this happens clean the fold rollers and potentially replace the staple cartridge to reduce this phenomenon
- When folding sheets without face trimming, a fold pressure line may occur at the opening side of the book. To prevent this phenomenon switch on Face trimming ON.

Limitations of the PBM350e/PBM500e system, cont.

- For some coated media the Face Trimmer may not be able to cut through the complete book. If this occur change to different media or reduce number of sheets in book.
This phenomenon has been observed on the following media:
 - Ohji materia OK art post (232.8 gsm)
- Books made from 1-3 sheets of thin media may show fold quality variation. If this occurs, first try “Precision Fold Mode” and if problem persist change media to improve quality.
- When running printer in PRODUCTIVITY MODE, the crease function in the RCT should not be used in AUTO mode, set the crease manually to either FINE or COARSE.
- Sensitive or thin media may show marks from back jogger mechanism if paper size is set too tight.
To eliminate adjust paper registration so registration is not so tight. These marks is easily cut away if Trimmer is switched on. Setting back jogger registration more loose by using Check Set Registration function will also reduce marks

8. Specification

Machine Specifications

PBM RCTe Rotate Crease Trim Module (option)

	Specifications	Remarks
Speed	Same as PBM350e/PBM500e Booklet Maker	
Standard Paper Sizes	Same as PBM350e/PBM500e Booklet Maker	
Paper Size Minimum (Out)	Same as PBM350e/PBM500e Booklet Maker	
Paper Size Maximum (Out)	Same as PBM350e/PBM500e Booklet Maker	
Paper Width Maximum (In)	330mm	5mm bleed trim will automatically be turned on
Paper Weight (Minimum)	Same as PBM350e/PBM500e Booklet Maker	
Paper Weight (Maximum)	Same as PBM350e/PBM500e Booklet Maker	Above 300gsm limited performance with some media
Rotator (optional) Rotation is only possible within the interval	Width (cross process direction) min. 275mm. (10.9"). Width (cross process direction) max. 325mm. (12.7"). Length (process direction) min. 205mm. (8.1"). Length (process direction) max. 232mm. (9.1").	
Creaser Tools Fine tool Coarse tool	Stock < 120 gsm Stock > 120 gsm (gsm =grams per sq. meter)	
Bleed Trimmer Minimum bleed trimming Maximum bleed trimming Max asymmetric bleed trimming	5 mm / 0.2" 30 mm / 1.2" ±5 mm / 0.2"	On each side of the set
Input / Output Sheets	Same as PBM350e/PBM500e Booklet Maker	
Input / Output Sheets	Same as PBM350e/PBM500e Booklet Maker	
Off-line Use	Not possible	
Weight	200kg/441lb	
Dimensions (L x H x D)	720 x 1115 x 755 / 38.5" x 44" x 30" (incl. 100mm / 4" waste transport)	
Power Source	100 - 230V ±10% 50-60Hz	
Power Consumption	300W	Continuous operation
	400W	Max

PBM350e/PBM500e Booklet Maker

Major Specifications

	Specifications	Remarks
Speed (Online usage)	Maintains engine speed.	Actual speed in number of booklets (per min / hour) depends on number of sheets per booklet.
Standard Paper Sizes	A4, SRA4, B4, A3, SRA3, 8.5x11", 8.5x14", 9x12", 11x17", 12x18"	Custom sizes are available
Paper Size (Minimum)	Width 206mm / 8.1" Length 275mm / 10.8"	For sheets under 209mm/8.23" in width registration quality could show larger variance
Paper Size (Maximum)	Width 320mm / 12.6" Length 457.2mm / 18"	
Paper Weight (Minimum)	64gsm/16lb Bond uncoated 105gsm coated	
Paper Weight (Maximum)	350gsm / 130lb Cover	
Belt stacker capacity	2 sheets: 200 sets 8 sheets: 70 sets 15 sheets: 35 sets 20 sheets: 25 sets 30 sheets: 15 sets 35 sheets: 15 sets 40 sheets: 10 sets 45 sheets: 10 sets 50 sheets: 10 sets	80gsm / 20lb Bond Figures are based on rough estimates and founded on pure observation
Folding/stapling capability	2 – 35 or 50 Sheets (80gsm / 20lb Bond)	See Set Size Guide for more information
Folding capability only	1 to 2 sheets	
Off-line use	Possible	Staple / Fold (2 staples)
Weight	148,5 kg / 327.4 lb	
Dimensions (L x H x D)	810 x 1050 x 725mm / 31.9 x 41.3 x 28.5"	Excluding belt stacker *
Power Source	100 - 230V, 50-60Hz	+ 6%, - 10%
Power consumption	250W or less	Continuous Operations
Noise emission	62dB	Complete system

*The Belt Stacker, installed after Booklet Maker, BookFold Module or Trimmer, adds 420 - 630mm / 16.5" - 24.8"

NOTE: Plockmatic uses QT open source license (LGPL) to develop the software used in this machine (<https://www.qt.io/qt-licensing-terms>).

Plockmatic Cover Feeder (option)

	Specifications	Remarks
Maximum Speed	Same as PBM350e/PBM500e Booklet Maker	A3/11x17" or bigger paper sizes, need two sheet sets as inlet at least
Standard Paper Sizes	Same as PBM350e/PBM500e Booklet Maker	
Paper Weight (Minimum)	64gsm / 16lb Bond	
Paper Weight (Maximum)	250gsm / 67lb Bond	
Cover Feeder Capacity	20mm (app. 200 sheets of 80gsm paper) 13/16" (app. 200 sheets of 20lb Bond paper)	
Off-line Use	Possible	(Together with Booklet maker)
Weight	7kg / 15.4 lb or less	
Dimensions (L x H x D)	310 x 190 x 530mm / 12.2 x 7.5 x 20.9"	The Cover Feeder dimensions are included in the Booklet Maker dimensions and will not add anything more to the space.
Power Source	From PBM350e/PBM500e Booklet Maker	

PBM Trim Module (option)

	Specifications	Remarks
Speed	1800 sets per hour	
Standard Paper Sizes	Same as PBM350e/PBM500e Booklet Maker	Custom sizes are available
Default trim length	4.5mm / (11/64")	Adjustable in 0.5mm (0.004") steps
Minimum trimming	1mm / (0.0394")*	Rec. min trim is 2,5mm (0.098")
Maximum trimming	16mm ($\frac{5}{8}$ ") per cut	Possible to trim down to 105mm ($4\frac{9}{64}$ "). Trim larger than 16mm ($\frac{5}{8}$ ") will cause trimmer to make multiple cycles. This reduces system speed in some applications. Multiple cuts also affect lifetime.
Paper Weight (Min)	Same as PBM350e/PBM500e Booklet Maker	
Paper Weight (Max)	Same as PBM350e/PBM500e Booklet Maker	
Input / Output Sheets	Same as PBM350e/PBM500e Booklet Maker	
Off-line Use	Possible	(Together with Booklet maker)
Weight	70kg / 154.3lb or less	
Dimensions (L x H x D)	360 x 1010 x 620mm / 14.2 x 39.8 x 24.4"	
Power Source	From PBM350e/PBM500e Booklet Maker	

* When trimming SRA3 (450mm) Booklets minimum trimming is 5mm, when trimming 18" Booklets minimum trimming is 9mm.

PBM BookFold Module (option)

	Specifications	Remarks
Speed	Same as PBM350e/PBM500e Booklet Maker	Appr. 6 - 30 sheet booklet (80gsm / 20lb Bond)
Standard Paper Sizes	Same as PBM350e/PBM500e Booklet Maker	Custom sizes are available
Paper Weight (Minimum)	Same as PBM350e/PBM500e Booklet Maker	
Paper Weight (Maximum)	Same as PBM350e/PBM500e Booklet Maker	
Input / Output Sheets	Same as PBM350e/PBM500e Booklet Maker	
Off-line Use	Possible	(Together with Booklet maker & Trimmer)
Weight	59kg / 130lb	
Dimensions	360 x 1010 x 620mm / 14.2 x 39.8 x 24.4"	
Power Source	From PBM350e/PBM500e Booklet Maker	

BST4000-1 Belt Stacker Module (option)

	Specifications	Remarks
Speed	Variable	
Overlap	Adjustable	
Capacity	A4 / 8,3"x11,7"≥ 1,000 A3 / 11,7"x16,5"≥ 500	Booklet of 2 sheets 80gsm / 20lb Bond Booklet of 2 sheets 80gsm / 20lb Bond
Side guides	Adjustable 0-357mm / 14"	
Weight	70kg/1541lb	
Dimensions Table height Width Length	575 - 1000mm / 22.6" - 39.4" 440mm / 17" 1380mm / 54"	Input height = Table height + 60mm / 2.4" + Control unit + 350mm / 14" for end stacking tray
Power Source	100 - 240V, 50-60Hz, 1A	+ 6%, - 10%
Power Consumption	70W or less	

Trim Waste Conveyor (option)

	Specifications	Remarks
Weight	30kg / 66.2lb	
Dimensions (L x H x D)	2245 x 1100 x 725mm / 88.4 x 43.3 x 28.5"	
Power Source	Belt driven from the RCT	

System Set Size Guide

NOTE:

The following tables are guidelines designed to give an indication of how many sheets a specific application can have at a given media weight.

On some coated media staples may not penetrate the set resulting in a faulty staple. If problem persists, consider changing media. Staple may not be able to penetrate the number of sheets indicated by the "Set Size Guide". Some uncoated extra "dense" paper may show the same limitation. The following media are examples of this:

Futura Laser Gloss 80c

Hammermill Laser Print

OPUS Gloss

Exact number of sheets is depending on media type and area coverage.

Paper weight						Plockmatic PBM500e				Plockmatic PBM350e			
						Paper Size				Paper Size			
						A3 or 11x17"		A4 or 8.5x11"		A3 or 11 x 17"		A4 or 8,5 x 11"	
						Area Coverage		Area Coverage		Area Coverage		Area Coverage	
Bond	Offset	Cover	Tag	Index	Gsm	Low	Full	Low	Full	Low	Full	Low	Full
20	50	28	46	42	80	50	32	50	32	35	25	35	25
24	60	33	56	50	90	45	32	44	32	30	20	30	20
31	81	45	73	66	120	25	24	25	24	22	19	22	19
36	90	50	82	75	140	22	20	22	20	20	15	20	15
43	110	60	100	90	160	20	18	20	18	18	17	18	17
53	135	74	122	110	200	15	14	15	14	13	10	13	10
58	146	80	134	120	220	13	12	13	12	11	9	11	9
67	170	93	156	140	250	12	11	12	11	10	9	10	9
76	192	105	175	158	280	11	10	11	10	9	7	9	7
82	208	114	189	170	300	9	9	9	9	8	6	8	6
94	236	130	215	200	350	7	7	7	7	6	5	6	5

NOTE:

- For cover jobs , deduct 2 sheets
- Paper size: large = <A3/11x17"> , Small = <A3/11x17"
- Area coverage: Low = text only, High = Pictures, Full = Maximum coverage
- For jobs with multiple sheets of 200 gsm or higher paper weight the BookFold module is recommended for an acceptable output

EU & UK DECLARATION OF CONFORMITY ^[1]

No. ^[2] **N0003153 (D.6)**

Manufacturer ^[3] Plockmatic International AB, Telefonvägen 30, S-126 26 Hägersten, Sweden

This Declaration of Conformity is issued under the sole responsibility of the manufacturer ^[4]

Object of the Declaration ^[5]				
Type/Model ^[6]	F102-012	F103-012	F104-004	F105-012
Name ^[7]	PBM350, PBM350e, PBM350-m PBM500, PBM500e, PBM500-m	PBM-TR, PBM-m TR	CF	PBM-BF, PBM-m BF
Description ^[8]	Booklet Maker	Trimmer	Cover Feeder	Book Fold Module

The object of the declaration is in conformity with the requirements of the following documents ^[9]	
EU Directive ^[10]	Standard ^[11]
UK Statutory Instrument	UK Designated Standard
(LVD) 2014/35/EU <i>S.I. 2016/1101</i>	EN 62368-1:2014 + A11:2017 EN IEC 62368-1:2020 + A11:2020
(EMC) 2014/30/EU <i>S.I. 2016/1091</i>	EN 55032:2015 + A11:2020 (Class A), EN 55035:2017 +A11:2020 EN 61000-3-2:2014, EN 61000-3-3:2013, EN/(IEC) 61000-6-4:2007+A1 EN/(IEC) 61000-6-4:2019, EN 62311:2008
(RoHS) 2011/65/EU <i>S.I. 2012/3032</i>	EN 62321-1:2013, EN 63000:2018
Additional information ^[12] International certification: UL 62368-1, 3 rd Edition, CSA C22.2 No. 62368-1:19, IEC 62368-1:2014+A11:2017, IEC 62368-1:2018, FCC CFR Part 15 Subpart B, Class B, ICES-003 Issue 5 Class B.	
Signed for and on behalf of ^[13] Hägersten, 2024-03-18 09:17	
 Bengt Olenfalk Group Quality Manager	

8

БЪЛГАРСКИ: 1) ЕС Декларация за съответствие; 2) Номер; 3) Производител; 4) Настоящата декларация за съответствие е издадена на отговорността на производителя; 5) Предмет на декларацията; 6) Модел/Тип; 7) Назначение; 8) Описание; 9) Предметът на декларацията, описан по-горе, отговаря на съответното законодателство на Съюза за хармонизация; 10) Директива; 11) Стандарт; 12) Допълнителна информация; 13) Подписано за и от името на

ČESKY: 1) EU Prohlášení o shodě; 2) Číslo; 3) Výrobce; 4) Toto prohlášení o shodě se vydává na výhradní odpovědnost výrobce; 5) Předmět prohlášení; 6) Model/Typ; 7) Označení; 8) Popis; 9) Výše popsaný předmět prohlášení je ve shodě s příslušnými harmonizačními právními předpisy Unie; 10) Směrnice; 11) Norma; 12) Dodatečné informace; 13) Podepsáno za a jménem na

DANSK: 1) EU-Overensstemmelseserklæring; 2) Nummer; 3) Producent; 4) Denne overensstemmelseserklæring udstedes på fabrikantens ansvar; 5) Erklæringens genstand; 6) Model/Type; 7) Betegnelse; 8) Beskrivelse; 9) Genstanden for erklæringen, som beskrevet ovenfor, er i overensstemmelse med den relevante EU-harmoniseringslovgivning; 10) Direktiv; 11) Standard; 12) Yderligere information; 13) Underskrevet for og vegne

DEUTSCH: 1) EU-Konformitätserklärung; 2) Nummer; 3) Hersteller; 4) Die alleinige Verantwortung für die Ausstellung dieser Konformitätserklärung trägt der Hersteller; 5) Gegenstand der Erklärung; 6) Modell/Typ; 7) Bezeichnung; 8) Beschreibung; 9) Der oben beschriebene Gegenstand der Erklärung erfüllt die einschlägigen Harmonisierungsrechtsvorschriften der Union; 10) Direktive; 11) Standard; 12) Weitere Informationen; 13) Zur Unterzeichnung und Namen

EESTI: 1) ELI Vastavusdeklaratsioon; 2) Number; 3) Valmistaja; 4) Käesolev vastavusdeklaratsioon on välja antud tootja ainuvastutusele; 5) Deklareeritav; 6) Mudel/Type; 7) Nimetus; 8) Kirjelus; 9) Eelkirjelatud deklareeritav toode on kooskõlas asjaomaste liidu ühtlustamisaktidega; 10) Direktiivi; 11) Standard; 12) Lisainfo; 13) Allkirjastatud ja nimel

SUOMI: 1) EU-Vaatimustenmukaisuusvakuutus; 2) Määrä; 3) Valmistaja; 4) Tämä vaatimustenmukaisuusvakuutus on annettu valmistajan yksinomaisella vastuulla; 5) Vakuutuksen kohde; 6) Malli/Tyyppi; 7) Nimitys; 8) Kuvaus; 9) Edellä kuvattu vakuutuksen kohde on asiaa koskevan unionin yhdenmukaistamislaainsäädännön vaatimusten mukainen; 10) Direktiivi; 11) Standardi; 12) Lisäinformaatio; 13) Allekirjoitettu ja puolesta

FRANÇAIS: 1) Déclaration UE de conformité; 2) Nombre; 3) Fabricant; 4) La présente déclaration de conformité est établie sous la seule responsabilité du fabricant; 5) Objet de la déclaration; 6) Modèle/type; 7) Désignation; 8) Description; 9) L'objet de la déclaration décrit ci-dessus est conforme à la législation d'harmonisation de l'Union applicable; 10) Directif; 11) Standard; 12) Informations Supplémentaires; 13) Signé pour et au nom de

GAEILGE: 1) Dearbhú comhréireachta AE; 2) Uimhir; 3) Manufacturer; 4) Tá an dearbhú comhréireachta arna eisiúint faoi fhreagracht an mhonaróra; 5) Cuspóir an dearbhaith; 6) Cineál; 7) Ainmní; 8) Tuairisc; 9) Is é cuspóir an dearbhaith a thugtar i gcomhréir leis an reachtaíocht chomhchuibhithe ábhartha an Aontais; 10) Treoir; 11) Caighdeánach; 12) Eolas breise; 13) Arna shíniú le haghaidh agus thar ceann an

ΕΛΛΗΝΙΚΗ: 1) Δήλωση συμμόρφωσης ΕΕ; 2) αριθμός; 3) Κατασκευαστής; 4) Η παρούσα δήλωση συμμόρφωσης εκδίδεται με αποκλειστική ευθύνη του κατασκευαστή; 5) Αντικείμενο της δήλωσης; 6) Μοντέλο/Τύπος; 7) Ονομασία; 8) Περιγραφή; 9) Ο στόχος της δήλωσης που περιγράφεται παραπάνω είναι σύμφωνα με τη σχετική ενωσιακή νομοθεσία εναρμόνισης; 10) Διευθυντικός; 11) Πρότυπο; 12) Επιπλέον πληροφορίες; 13) Υπογραφή για λογαριασμό και εξ ονόματος του

HRVATSKI: 1) EU Izjava o sukladnosti; 2) Broj; 3) Proizvođač; 4) Za izdavanje EU izjave o sukladnosti odgovoran je isključivo proizvođač; 5) Predmet deklaracije; 6) Model/Tip; 7) Oznaka; 8) Deskripcija; 9) Predmet navedene izjave u skladu je s mjerodavnim zakonodavstvom Unije o uskladjivanju; 10) Direktiva; 11) Standard; 12) Dodatne informacije; 13) Potpisao za iu ime

MAGYAR: 1) EU-Megfelelőségi nyilatkozat; 2) Szám; 3) Gyártó; 4) Ezt a megfeleléségi nyilatkozatot a gyártó kizárólagos felelőssége mellett adja ki; 5) A nyilatkozat tárgya; 6) Modell/Típus; 7) Kijelölés; 8) Leírás; 9) A fent ismertetett nyilatkozat tárgya megfelel a vonatkozó uniós harmonizációs jogszabályoknak; 10) Irányelv; 11) Standard; 12) További információ; 13) Aláírva nevében

ISLENSKA: 1) ESB Leyfisyfyrirlysing; 2) Fjöldi; 3) Framleiðandi; 4) Þessi samræmisyfyrirlysing er sett alfrjó á ábyrgð framleiðanda; 5) Markmið yfyrirlysingarinnar; 6) Gerð; 7) Tilnefning; 8) Lýsing; 9) Markmið yfyrirlysingarinnar lýst er hér að ofan er í samræmi við viðeigandi Union samhæfingu löggjafar; 10) Tilskipun; 11) Standard; 12) Viðbótarupplýsingar; 13) Undirritað fyrir og fyrir hönd

ITALIANO: 1) Dichiarazione di conformità UE; 2) Numero; 3) Produttore; 4) La presente dichiarazione di conformità è rilasciata sotto la responsabilità esclusiva del fabbricante; 5) Oggetto della dichiarazione; 6) Modello/Tip; 7) Designazione; 8) Descrizione; 9) L'oggetto della dichiarazione di cui sopra è conforme alla pertinente normativa di armonizzazione dell'Unione; 10) Direttiva; 11) Standard; 12) Informazioni aggiuntive; 13) Firmato e per conto di

LATVIEŠU: 1) ES Atbilstības deklarācija; 2) Numurs; 3) Ražotājs; 4) Šī atbilstības deklarācija ir izdota vienīgi uz ražotāja atbildību; 5) Deklarācijas priekšmets; 6) Modeļa/tipa; 7) Apzīmējums; 8) Apraksts; 9) Iepriekš aprakstītais deklarācijas priekšmets atbilst attiecīgajam Savienības saskaņošanas tiesību aktam; 10) Direktīva; 11) Standarts; 12) Papildoma informācija; 13) Parakstīts vārdā

LIETUVIŲ: 1) ES Atitikties deklaracija; 2) Skaičius; 3) Gamintojas; 4) Ši atitikties deklaracija išduota tik gamintojo atsakomybe; 5) Deklaracijos objektas; 6) Modelis/tipas; 7) Pavadinimas; 8) Aprašymas; 9) Firmiui aprašytas deklaracijos objektas atitinka susijusius derinamusius Sąjungos teisės aktus; 10) Direktyva; 11) Standartinė; 12) Papildoma informacija; 13) Pasirašyta ir vardu

MALTESE: 1) Dikjarazzjoni ta' konformità tal-UE; 2) Numru; 3) Manifattur; 4) Din id-dikjarazzjoni ta' konformità tinhareg taht ir-responsabbiltà unika tal-manifattur; 5) Għan tad-dikjarazzjoni; 6) Mudell/Tip; 7) Deżinjazzjoni; 8) Deskrizzjoni; 9) L-għan tad-dikjarazzjoni deskritt hawn fuq huwa konformi mal-leġislazzjoni ta' armonizzazzjoni rilevanti tal-Unjoni; 10) Direttiva; 11) Standard; 12) Informazzjoni addizzjonali; 13) Iffirmat għal u fisem il

NEDERLANDS: 1) EU-Conformiteitsverklaring; 2) Nummer; 3) Fabrikant; 4) Deze conformiteitsverklaring wordt verstrekt onder volledige verantwoordelijkheid van de fabrikant; 5) Voorwerp van de verklaring; 6) Model/Type; 7) Benaming; 8) Beschrijving; 9) Hier hierboven beschreven voorwerp is in overeenstemming met de desbetreffende harmonisatiewetgeving van de Unie; 10) Richtlijn; 11) Standaard; 12) Aanvullende informatie; 13) Ondertekend voor en namens

NORSK: 1) EU-Erklæring; 2) Nummer; 3) Producent; 4) Denne samsvarserklæringen er utstedt under ansvar av produsenten; 5) Formålet med erklæringen; 6) Type; 7) Betegnelse; 8) Beskrivelse; 9) Formålet med erklæringen som er beskrevet ovenfor er i samsvar med relevante Union harmoniseringslovgivning; 10) Direktiv; 11) Standard; 12) Ytterligere informasjon; 13) Signert for og vegne av

POLSKI: 1) Deklaracja zgodności UE; 2) Numer; 3) Producent; 4) Niniejsza deklaracja zgodności wydana zostaje na wyłączną odpowiedzialność producenta; 5) Przedmiot deklaracji; 6) Model/Typ; 7) Oznaczenie; 8) Opis; 9) Wymieniony powyżej przedmiot niniejszej deklaracji jest zgodny z odpowiednimi wymaganiami unijnego prawodawstwa harmonizacyjnego; 10) Dyrektywa; 11) Standard; 12) Dodatkowe informacje; 13) Podpisano imieniem

PORTUGUÊS: 1) Declaração UE de conformidade; 2) Número; 3) Fabricante; 4) A presente declaração de conformidade é emitida sob a exclusiva responsabilidade do fabricante; 5) Objeto da declaração; 6) Modelo/Tip; 7) A denominação; 8) Descrição; 9) O objeto da declaração acima descrito está em conformidade com a legislação de harmonização da União aplicável; 10) Diretiva; 11) Padrão; 12) Informações adicionais; 13) Assinado por e nome

ROMÂNĂ: 1) Declarația UE de conformitate; 2) Număr; 3) Producător; 4) Prezenta declarație de conformitate este emisă pe răspunderea exclusivă a producătorului; 5) Obiectul declarației; 6) Model/Tip; 7) Desemnare; 8) Descriere; 9) Obiectul declarației descris mai sus este în conformitate cu legislația relevantă de armonizare a Uniunii; 10) Directivă; 11) Standard; 12) Informații adiționale; 13) Semnat pentru și în numele

SLOVENSKY: 1) EU Vyhlášení o shodě; 2) Číslo; 3) Výrobce; 4) Toto vyhlášení o shodě sa vydáva na výhradnú zodpovednosť výrobcu; 5) Predmet vyhlášenja; 6) Model/Typ; 7) Označenie; 8) Popis; 9) Uvedený predmet vyhlášenja je v zhode s príslušnými harmonizačnými právnymi predpismi Unie; 10) Smernice; 11) Štandardné; 12) Doplnjujúce informácie; 13) Podpísané za av mene na

SLOVENŠČINA: 1) Izjava EU o skladnosti; 2) Številko; 3) Proizvajalec; 4) Ta izjava o skladnosti je izdana na lastno odgovornost proizvajalca; 5) Predmet izjave; 6) Model/Type; 7) Oznaka; 8) Opis; 9) Predmet navedene izjave je v skladu z ustreznimi zakonodajami Unije o harmonizaciji; 10) Direktiva; 11) Standardna; 12) Dodatne informacije; 13) Podpisano za in v imenu

ESPAÑOL: 1) Declaración UE de conformidad; 2) Número; 3) Fabricante; 4) La presente declaración de conformidad se expide bajo la exclusiva responsabilidad del fabricante; 5) Objeto de la declaración; 6) Tipo de modelo; 7) Designación; 8) Descripción; 9) El objeto de la declaración descrita anteriormente es conforme con la legislación de armonización pertinente de la Unión; 10) Directiva; 11) Estándar; 12) Información Adicional; 13) Firmado por y nombre

EU & UK DECLARATION OF CONFORMITY ^[1]

No.^[2] **D0001499 (I.11)**

Manufacturer ^[3] Plockmatic International AB, Telefonvägen 30, S-126 26 Hägersten, Sweden

This Declaration of Conformity is issued under the sole responsibility of the manufacturer ^[4]

Object of the Declaration ^[5]										
Type/Model ^[6]	F122-001	F122-002	F122-003	F122-012	F122-013	F122-012	F122-103	F134-001	F135-001	F136-001, F136-002, F136-003, F136-004
Name ^[7]	RCT, RCT 2.0, RCT30 (4B7, BE6)	CT5010e, CT5030, CST500, CST2000, PBM-RCT (2.0), RCT50, SD-RCT	PBM-RCTe	RCT 3.0	PBM-RCT 3.0, CST 3.0, CST3000, RCT 3.0, SD-RCT 3.0	CT XL	CT XL Bridge	SD-INT	PBM PUMO	Trim Waste Conveyor TWC 2.0
Description ^[8]	Rotator Creaser Trimmer						Interface		Purge Module	(option)

The object of the declaration is in conformity with the requirements of the following documents ^[9]	
EU Directive ^[10]	Standard ^[11]
UK Statutory Instrument	UK Designated Standard
(LVD) 2014/35/EU <i>S.I. 2016/1101</i>	EN 62368-1:2014 + A11:2017, EN IEC 62368-1:2020 + A11:2020
(EMC) 2014/30/EU <i>S.I. 2016/1091</i>	EN 55032:2015 + AC1:2016 + A1:2020 + A11:2020 (Class A), EN 55035:2017 + A11:2020, EN 61000-3-2:2014, EN 61000-3-3:2013, EN 61000-6-2:2005, EN 61000-6-4:2007+A1
(RoHS) 2011/65/EU <i>S.I. 2012/3032</i>	EN 62321:2009, EN 63000:2018
Additional information ^[12] Compliant with: EN IEC 62368-1:2020+A11:2020; IEC 62368-1: 2018, 3 rd Edition; UL 62368-1, 3 rd Edition, 2019; CAN/CSA C22.2 No. 62368-1:19, 3 rd Edition; FCC Part 15 (2015) Subpart B Class A; ICES-003 Issue 6 Class A	
Signed for and on behalf of ^[13] Hägersten, 2025-02-05 07:46	
 Bengt Olenfalk Group Quality Manager	

БЪЛГАРСКИ: 1) ЕС Декларация за съответствие; 2) Номер; 3) Производител; 4) Настоящата декларация за съответствие е издадена на отговорността на производителя; 5) Предмет на декларацията; 6) Модел/Тип; 7) Назначение; 8) Описание; 9) Предметът на декларацията, описан по-горе, отговаря на съответното законодателство на Съюза за хармонизация; 10) Директива; 11) Стандарт; 12) Допълнителна информация; 13) Подписано за и от името на

ČESKY: 1) EU Prohlášení o shodě; 2) Číslo; 3) Výrobce; 4) Toto prohlášení o shodě se vydává na výhradní odpovědnost výrobce; 5) Předmět prohlášení; 6) Model/Typ; 7) Označení; 8) Popis; 9) Výše popsaný předmět prohlášení je ve shodě s příslušnými harmonizačními právními předpisy Unie; 10) Směrnice; 11) Norma; 12) Dodatečné informace; 13) Podpisáno za jménem na

DANSK: 1) EU-Overensstemmelseserklæring; 2) Nummer; 3) Producent; 4) Denne overensstemmelseserklæring udstedes på fabrikantens ansvar; 5) Erklæringens genstand; 6) Model/Type; 7) Betegnelse; 8) Beskrivelse; 9) Genstanden for erklæringen, som beskrevet ovenfor, er i overensstemmelse med den relevante EU-harmoniseringslovgivning; 10) Direktiv; 11) Standard; 12) Yderligere information; 13) Underskrevet for og ved navn

DEUTSCH: 1) EU-Konformitätserklärung; 2) Nummer; 3) Hersteller; 4) Die alleinige Verantwortung für die Ausstellung dieser Konformitätserklärung trägt der Hersteller; 5) Gegenstand der Erklärung; 6) Bezeichnung; 7) Beschreibung; 8) Der oben beschriebene Gegenstand der Erklärung erfüllt die einschlägigen Harmonisierungsrechtsvorschriften der Union; 10) Richtlinie; 11) Standard; 12) Weitere Informationen; 13) Zur Unterzeichnung und Namen

EESTI: 1) EU Vastavastumekaisusavakutus; 2) Number; 3) Valmistaja; 4) Käesolev vastavastumekaisusavakutus on annettu valmistajan yksinomaisella vastuulla; 5) Vakukuutus kohde; 6) Malli/Typi; 7) Nimetus; 8) Kuvasus; 9) Edellä kuvattu vakukuutuksen kohde on asias koskevan unionin yhdenmukaisustamisalainsäädännön vaatimusten mukainen; 10) Direktiiv; 11) Standard; 12) Lisäinformaatio; 13) Allekirjoitetut ja puolesta

EUOMI: 1) EU-Vaatimustenmukaisuusvakuutus; 2) Määrä; 3) Valmistaja; 4) Tämä vaatimustenmukaisuusvakuutus on annettu valmistajan yksinomaisella vastuulla; 5) Vakuutuksen kohde; 6) Malli/Typi; 7) Nimitys; 8) Kuvasus; 9) Edellä kuvattu vakuutuksen kohde on asiaa koskevan unionin yhdenmukaisustamisalainsäädännön vaatimusten mukainen; 10) Direktiiv; 11) Standard; 12) Lisäinformaatio; 13) Allekirjoitetut ja puolesta

FRANÇAIS: 1) Déclaration UE de conformité; 2) Nombre; 3) Fabricant; 4) La présente déclaration de conformité est établie sous la seule responsabilité du fabricant; 5) Objet de la déclaration; 6) Modèle/type; 7) Désignation; 8) Description; 9) L'objet de la déclaration décrit ci-dessus est conforme à la législation d'harmonisation de l'Union applicable; 10) Directive; 11) Standard; 12) Informations Supplémentaires; 13) Signé pour et au nom de

GAELEGE: 1) Dearbhú comhréireachtá AE; 2) Uimhir; 3) Manúfactúr; 4) Tá an dearbhú comhréireachtá arna eisiúint faoi fhreagracht an mhonaróra; 5) Cuspóir an dearbháithe a thugtar i gcomhréir leis an reachtáilocht chomhréireachtá ábhartha an Aontais; 10) Treoir; 11) Ceanglaiséanna; 12) Eolais breise; 13) Arna shíniú le haghaidh agus thar ceann an

EA/HHKKH: 1) Дължностна декларация; 2) Номер; 3) Производител; 4) H настоящата декларация е издадена на изцяло отговорността на производителя; 5) Предмет на декларацията; 6) Модел/Тип; 7) Назначение; 8) Описание; 9) Предметът на декларацията, описан по-горе, отговаря на съответното законодателство на Съюза за хармонизация; 10) Директива; 11) Стандарт; 12) Допълнителна информация; 13) Подписано за и от името на

HRVATSKI: 1) EU izjava o skladnosti; 2) Broj; 3) Proizvođač; 4) Za izdavanje EU izjave o skladnosti odgovoran je isključivo proizvođač; 5) Predmet deklaracije; 6) Model/Tip; 7) Oznaka; 8) Deskripcija; 9) Predmet navedene izjave u skladu je s mjerodavnim zakonodavstvom Unije o usklađivanju; 10) Direktiva; 11) Standard; 12) Dodatne informacije; 13) Potpisao za iu ime

MAGYAR: 1) EU-Megfelelősegi nyilatkozat; 2) Szám; 3) Gyártó; 4) Ezt a megfelelősegi nyilatkozatot a gyártó kizárólagos felelőssége mellett adják ki; 5) A nyilatkozat tárgya; 6) Modell/Típus; 7) Kijelölés; 8) Leírás; 9) A fent ismertetett nyilatkozat tárgya megfelel a vonatkozó uniós harmonizációs jogszabályoknak; 10) Irányelv; 11) Standard; 12) További információ; 13) Aláírva nevében

ISLENSKA: 1) ESB Leyfyrirfyring; 2) Fjöldi; 3) Framleiðandi; 4) Þessi samræmisfyrirfyring er sett alfrjó á ábyrgð framleiðanda; 5) Markmið fyrirfyringarrinnar; 6) Gerð; 7) Tilnefning; 8) Lýsing; 9) Markmið fyrirfyringarrinnar lýst er hér að ofan er í samræmi við viðeigandi Union samræmningu löggjafar; 10) Tilskipun; 11) Standard; 12) Viðbótarupplýsingar; 13) Undirritað fyrir og fyrir hönd

ITALIANO: 1) Dichiarazione di conformità UE; 2) Numero; 3) Produttore; 4) La presente dichiarazione di conformità è rilasciata sotto la responsabilità esclusiva del fabbricante; 5) Oggetto della dichiarazione; 6) Modello/Tipi; 7) Designazione; 8) Descrizione; 9) L'oggetto della dichiarazione di cui sopra è conforme alla pertinente normativa di armonizzazione dell'Unione; 10) Direttiva; 11) Standard; 12) Informazioni aggiuntive; 13) Firmato e per conto di

LATVIEŠU: 1) ES Atbilstības deklarācija; 2) Numurs; 3) Ražotājs; 4) Šī atbilstības deklarācija ir izdota vienīgi uz ražotāja atbildību; 5) Deklarācijas priekšmets; 6) Modeļa/Tipi; 7) Apzīmējums; 8) Apraksts; 9) Iepriekš aprakstītais deklarācijas priekšmets atbilst attiecīgajam Savienības saskaņotās tiesību aktam; 10) Direktīva; 11) Standarts; 12) Papildus informācija; 13) Parakstīts vārds

LIEUTUVIŲ: 1) ES Atitikties deklaracija; 2) Skaičius; 3) Gamintojas; 4) Ši atitikties deklaracija išduota tik gamintojo atsakomybe; 5) Deklaracijos objektas; 6) Modelių/Tipai; 7) Pavadinimas; 8) Aprašymas; 9) Pirmiau aprašytas deklaracijos objektas atitinka susijusių derinamumous Sąjungos teisės aktus; 10) Direktyva; 11) Standartinė; 12) Papildoma informacija; 13) Pasirašyta ir vardu

MALTESE: 1) Dikjarazzjoni ta' konformità tal-UE; 2) Numru; 3) Manifattur; 4) Din id-dikjarazzjoni ta' konformità tinhaq taht ir-responsabbiltà unika tal-manifattur; 5) Għan tad-dikjarazzjoni; 6) Mudell/Tip; 7) Deżinjazzjoni; 8) Deskrizzjoni; 9) L-għan tad-dikjarazzjoni deskritt hawn fuq huwa konformi mal-legiżlazzjoni ta' armonizzazzjoni rilevanti tal-Unjoni; 10) Direttiva; 11) Standard; 12) Informazzjoni addizzjonali; 13) Iffirmat għal u f'isem il

NEDERLANDS: 1) EU-Conformiteitsverklaring; 2) Nummer; 3) Fabrikant; 4) Deze conformiteitsverklaring wordt verstrekt onder volledige verantwoordelijkheid van de fabrikant; 5) Voorwerp van de verklaring; 6) Model/Type; 7) Benaming; 8) Beschrijving; 9) Het hierboven beschreven voorwerp is in overeenstemming met de desbetreffende harmonisatiewetgeving van de Unie; 10) Richtlijn; 11) Standard; 12) Aanvullende informatie; 13) Ondertekend voor en namens

NORSK: 1) EU-Erklæring; 2) Nummer; 3) Producent; 4) Denne samsvarserklæring er utstedt under ansvar av produsenten; 5) Formålet med erklæringen; 6) Type; 7) Betegnelse; 8) Beskrivelse; 9) Formålet med erklæringen som er beskrevet ovenfor er i samsvar med relevante Union harmoniseringslovgivning; 10) Direktiv; 11) Standard; 12) Ytterligere informasjon; 13) Signert for og ved navn

POLSKI: 1) Deklaracja zgodności UE; 2) Numer; 3) Producent; 4) Niniejsza deklaracja zgodności wydane zostaje na wyłączną odpowiedzialność producenta; 5) Przedmiot deklaracji; 6) Model/Typ; 7) Oznaczenie; 8) Opis; 9) Wymieniony powyżej przedmiot niniejszej deklaracji jest zgodny z odnosnymi wymaganiami unijnego prawodawstwa harmonizacyjnego; 10) Dyrektywa; 11) Standard; 12) Dodatkowe informacje; 13) Podpisano imieniem

PORTUGUÊS: 1) Declaração UE de conformidade; 2) Número; 3) Fabricante; 4) A presente declaração de conformidade é emitida sob a exclusiva responsabilidade do fabricante; 5) Objeto da declaração; 6) Modelo/Tipos; 7) A denominação; 8) Descrição; 9) O objeto da declaração acima descrito está em conformidade com a legislação de harmonização da União aplicável; 10) Diretiva; 11) Padrão; 12) Informações adicionais; 13) Assinado por e nome

ROMÂNĂ: 1) Declarația UE de conformitate; 2) Număr; 3) Producător; 4) Prezenta declarație de conformitate este emisă pe răspundere exclusivă a producătorului; 5) Obiectul declarației; 6) Model/Tip; 7) Desemnare; 8) Descriere; 9) Obiectul declarației descris mai sus este în conformitate cu legislația relevantă de armonizare a Uniunii; 10) Directivă; 11) Standard; 12) Informații adiționale; 13) Semnat pentru și în numele

SLOVENSKÝ: 1) EU Vyhlásenie o zhode; 2) Číslo; 3) Výrobca; 4) Toto vyhlásenie o zhode sa vydáva na výhradnú zodpovednosť výrobcu; 5) Predmet vyhlásenia; 6) Model/Typ; 7) Označenie; 8) Popis; 9) Uvedený predmet vyhlásenia je v zhode s príslušnými harmonizačnými právnymi predpismi Unie; 10) Smernice; 11) Norma; 12) Doplnujúce informácie; 13) Podpísané za a meno na

SLOVENŠČINA: 1) Izjava EU o skladnosti; 2) Številko; 3) Proizvajalec; 4) Ta izjava o skladnosti je izdana na lastno odgovornost proizvajalca; 5) Predmet izjave; 6) Model/Type; 7) Oznaka; 8) Opis; 9) Predmet navedene izjave je v skladu z ustreznim zakonodajom Unije o harmonizaciji; 10) Direktiva; 11) Standard; 12) Dodatne informacije; 13) Podpisano za in v imenu

ESPAÑOL: 1) Declaración UE de conformidad; 2) Número; 3) Fabricante; 4) La presente declaración de conformidad se expide bajo la exclusiva responsabilidad del fabricante; 5) Objeto de la declaración; 6) Tipo de modelo; 7) Designación; 8) Descripción; 9) El objeto de la declaración descrita anteriormente es conforme con la legislación de armonización pertinente de la Unión; 10) Directiva; 11) Estándar; 12) Información Adicional; 13) Firmado por y nombre

SVENSKA: 1) EU-Försäkran om överensstämmelse; 2) Nummer; 3) Tillverkare; 4) Denna försäkran om överensstämmelse utfärdas på tillverkarens eget ansvar; 5) Föremålet för försäkran; 6) Model/Typ; 7) Beteckning; 8) Beskrivning; 9) Föremålet för försäkran ovan överensstämmer med den relevanta harmoniserade unionslagstiftningen; 10) Direktiv; 11) Standard; 12) Extra information; 13) Undertecknat för och på uppdrag av

EU & UK DECLARATION OF CONFORMITY [1]

No. [2] **D0000356 (K.6)**

Manufacturer [3] Plockmatic International AB, Telefonvägen 30, S-126 26 Hägersten, Sweden

This declaration of conformity is issued under the sole responsibility of the manufacturer [4]

Object of the Declaration [5]	
Type/Model [6]	PL4700, F680
Name [7]	BST4000, BST4000-1, F680, Y980, BST6200, F656, PLBS
Description [8]	Belt Conveyor Stacker

The object of the declaration is in conformity with the requirements of the following documents [9]	
EU Directive [10] <i>UK Statutory Instrument</i>	Standard [11] <i>UK Designated Standard</i>
(LVD) 2014/35/EU <i>S.I. 2016/1101</i>	EN 62368-1:2014 + A11:2017
(EMC) 2014/30/EU <i>S.I. 2016/1091</i>	EN 55032:2015 + A11:2020, Class A, EN 55035:2017 + A11:2020, EN 61000-3-2:2014, EN 61000-3-3:2013, EN 61000-6-2:2019, EN 61000-4-3, -4, -11
(RoHS) 2011/65/EU <i>S.I. 2012/3032</i>	EN 62321:2009, EN 63000:2018
Additional information [12] International certification: UL 62368-1, 2nd Ed, 2014-12-01, CAN/CSA C22.2 No. 62368-1-14, 2nd Ed., FCC Part 15 (2015) Subpart B, Class A, ICES-003 Issue 7, Class A, IEC 62368-1:2014 (Second Edition). List of countries addressed: Australia / New Zealand, EU Group and National Differences, Japan, USA / Canada	
Signed for and on behalf of [13] Hägersten, 2025-03-04 07:16	
 Bengt Olenfalk Group Quality Manager	

8

БЪЛГАРСКИ: 1) ЕС Декларация за съответствие; 2) Номер; 3) Производител; 4) Настоящата декларация за съответствие е издадена на отговорността на производителя; 5) Предмет на декларацията; 6) Модел/Тип; 7) Назначение; 8) Описание; 9) Предметът на декларацията, описан по-горе, отговаря на съответното законодателство на Съюза за хармонизация; 10) Директива; 11) Стандарт; 12) Допълнителна информация; 13) Подписано за и от името на

CESKY: 1) EU Prohlášení o shodě; 2) Číslo; 3) Výrobce; 4) Toto prohlášení o shodě se vydává na výhradní odpovědnost výrobce; 5) Předmět prohlášení; 6) Model/Typ; 7) Označení; 8) Popis; 9) Vyše popsaný předmět prohlášení je ve shodě s příslušnými harmonizačními právními předpisy Unie; 10) Směrnice; 11) Norma; 12) Dodatečné informace; 13) Podpisáno za a jménem na

DANSK: 1) EU-Overensstemmelseserklæring; 2) Nummer; 3) Producent; 4) Denne overensstemmelseserklæring udstedes på fabrikantens ansvar; 5) Erklæringens genstand; 6) Model/Type; 7) Betegnelse; 8) Beskrivelse; 9) Genstanden for erklæringen, som beskrevet ovenfor, er i overensstemmelse med den relevante EU-harmoniseringslovgivning; 10) Direktiv; 11) Standard; 12) Yderligere information; 13) Underskrevet for og vegne

DEUTSCH: 1) EU-Konformitätserklärung; 2) Nummer; 3) Hersteller; 4) Die alleinige Verantwortung für die Ausstellung dieser Konformitätserklärung trägt der Hersteller; 5) Gegenstand der Erklärung; 6) Modell/Type; 7) Bezeichnung; 8) Beschreibung; 9) Der oben beschriebene Gegenstand der Erklärung erfüllt die einschlägigen Harmonisierungsrechtsvorschriften der Union; 10) Direktive; 11) Standard; 12) Weitere Informationen; 13) Zur Unterzeichnung und Namen

EESTI: 1) EU Vastavusdeklaratsioon; 2) Number; 3) Valmistaja; 4) Käesolev vastavusdeklaratsioon on välja antud tootja ainuvastutusel; 5) Deklareeritav; 6) Model/Type; 7) Nimetus; 8) Kirjeldus; 9) Eelkirjelatud deklareeritav toode on kooskõlas asjastaste liidu ühtlustamisaktidega; 10) Direktiiv; 11) Standard; 12) Lisainfo; 13) Allkirjastatud ja nimel

ESOMI: 1) EU-Vaatumustenmukaisuuskäytäntö; 2) Määrä; 3) Valmistaja; 4) Tämä vaatustenmukaisuuskäytäntö on annettu valmistajan yksinomaista vastuulla; 5) Vakuutuksen kohde; 6) Malli/tyyppi; 7) Nimitys; 8) Kuvaus; 9) Edellä kuvattu vakuutuksen kohde on asiaa koskevan unionin yhdenmukaistamislainsäädännön vaatusten mukainen; 10) Direktiivi; 11) Standardi; 12) Lisätietoja; 13) Allekirjoitettu ja puolesta

FRANÇAIS: 1) Déclaration UE de conformité; 2) Numéro; 3) Fabricant; 4) La présente déclaration de conformité est établie sous la seule responsabilité du fabricant; 5) Objet de la déclaration; 6) Modèle/type; 7) Désignation; 8) Description; 9) L'objet de la déclaration décrit ci-dessus est conforme à la législation d'harmonisation de l'Union applicable; 10) Directif; 11) Standard; 12) Information Supplémentaire; 13) Signé pour et au nom de

GAEILGÉ: 1) Dearbhú comhréireachta AE; 2) Uimhir; 3) Manufacturer; 4) Tá an dearbhú comhréireachta arna eisiúint faoi fhreagracht an mhonaróra; 5) Cuspóir an dearbhaite; 6) Cineál; 7) Ainmniú; 8) Tuairisc; 9) Is é cuspóir an dearbhaite a thugtar i gcomhréir leis an reachtaíocht chomhchultúiríthe ábhartha an Aontais; 10) Treoir; 11) Caighdeánach; 12) Eolas breise; 13) Arna shíniú le haghaidh agus thar ceann an

ΕΛΛΗΝΙΚΗ: 1) Δήλωση συμμόρφωσης ΕΕ; 2) αριθμός; 3) Κατασκευαστής; 4) Η παρούσα δήλωση συμμόρφωσης εκδίδεται με αποκλειστική ευθύνη του κατασκευαστή; 5) Αντικείμενο της δήλωσης; 6) Μοντέλο/Τύπος; 7) Ονομασία; 8) Περιγραφή; 9) Ο στόχος της δήλωσης που περιγράφεται παραπάνω είναι σύμφωνα με τη σχετική ευρωπαϊκή νομοθεσία εναρμόνισης; 10) Διευθυντικός; 11) Πρότυπο; 12) Επιπλέον πληροφορίες; 13) Υπογραφή για λογαριασμό και εξ ονόματος του

HRVATSKI: 1) EU Izjava o sukladnosti; 2) Broj; 3) Proizvođač; 4) Za izdavanje EU izjave o sukladnosti odgovoran je isključivo proizvođač; 5) Predmet deklaracije; 6) Model/Tip; 7) Oznaka; 8) Deskripcija; 9) Predmet navedene izjave u skladu je s mjerodavnim zakonodavstvom Unije o usklađivanju; 10) Direktiva; 11) Standard; 12) Dodatne informacije; 13) Potpisao za i u ime

MAGYAR: 1) EU-Megfelelőségi nyilatkozat; 2) Szám; 3) Gyártó; 4) Ezt a megfeleléségi nyilatkozatot a gyártó kizárólagos felelőssége mellett adják ki; 5) A nyilatkozat tárgya; 6) Modell/Típus; 7) Kijelölés; 8) Leírás; 9) A fent ismertetett nyilatkozat tárgya megfelel a vonatkozó uniós harmonizációs jogszabályoknak; 10) Irányelv; 11) Standard; 12) További információ; 13) Aláírva nevében

ISLENSKA: 1) ESB Leyfisfyrirýsing; 2) Fjöldi; 3) Framleiðandi; 4) Þessi samræmisfyrirýsing er sett alfarir á ábyrgð framleiðanda; 5) Markmið fyrirýsingarinnar; 6) Gerð; 7) Tilnefning; 8) Lýsing; 9) Markmið fyrirýsingarinnar lýst er hér að ofan er í samræmi við viðeigandi Union samhefningu löggjafar; 10) Tilskip; 11) Standard; 12) Viðbótarupplýsingar; 13) Undirritað fyrir og fyrir hönd

ITALIANO: 1) Dichiarazione di conformità UE; 2) Numero; 3) Produttore; 4) La presente dichiarazione di conformità è rilasciata sotto la responsabilità esclusiva del fabbricante; 5) Oggetto della dichiarazione; 6) Modello/Tipo; 7) Designazione; 8) Descrizione; 9) L'oggetto della dichiarazione di cui sopra è conforme alla pertinente normativa di armonizzazione dell'Unione; 10) Direttiva; 11) Standard; 12) Informazioni aggiuntive; 13) Firmato e per conto di

LATVIJŅU: 1) ES Atbilstības deklarācija; 2) Numurs; 3) Ražotājs; 4) Šī atbilstības deklarācija ir izdota vienīgi uz ražotāja atbildību; 5) Deklarācijas priekšmets; 6) Modelis/tips; 7) Apzīmējums; 8) Apraksts; 9) Iepriekš aprakstītais deklarācijas priekšmets atbilst attiecīgajam Savienības saskaņošanas tiesību aktam; 10) Direktīva; 11) Standarts; 12) Papildus informācija; 13) Parakstīts vārdā

LIETUVIŲ: 1) ES Atitikties deklaracija; 2) Skaičius; 3) Gamintojas; 4) Ši atitikties deklaracija išduota tik gamintojo atsakomybe; 5) Deklaracijos objektas; 6) Modelis/tipas; 7) Pavadinimas; 8) Aprašymas; 9) Pirmiau aprašytas deklaracijos objektas atitinka susijusius derinamuosius Sąjungos teisės aktus; 10) Direktyva; 11) Standartinė; 12) Papildoma informacija; 13) Pasirašyta ir vardu

MALTESE: 1) Dikjarazzjoni ta' konformità tal-UE; 2) Numru; 3) Manifattur; 4) Din id-dikjarazzjoni ta' konformità tinhaqg taht ir-responsabbiltà unika tal-manifattur; 5) Għan tad-dikjarazzjoni; 6) Mudell/Tip; 7) Deżinjazzjoni; 8) Deskrizzjoni; 9) L-għan tad-dikjarazzjoni deskritt hawn fuq huwa konformi mal-legislazzjoni ta' armonizzazzjoni rilevanti tal-Unjoni; 10) Direttiva; 11) Standard; 12) Informazzjoni addizzjonali; 13) Iffirmat għal u fisem il

NEDERLANDS: 1) EU-Conformiteitsverklaring; 2) Nummer; 3) Fabrikant; 4) Deze conformiteitsverklaring wordt verstrekt onder volledige verantwoordelijkheid van de fabrikant; 5) Voorwerp van de verklaring; 6) Model/Type; 7) Benaming; 8) Beschrijving; 9) Het hierboven beschreven voorwerp is in overeenstemming met de desbetreffende harmonisatiewetgeving van de Unie; 10) Richtlijn; 11) Standard; 12) Aanvullende informatie; 13) Ondertekend voor en namens

NORSK: 1) EU-Erklæring; 2) Nummer; 3) Produsent; 4) Denne samsvarserklæringen er utstedt under ansvar av produsenten; 5) Formålet med erklæringen; 6) Type; 7) Betegnelse; 8) Beskrivelse; 9) Formålet med erklæringen som er beskrevet ovenfor er i samsvar med relevante Union harmoniseringslovgivning; 10) Direktiv; 11) Standard; 12) Ytterligere informasjon; 13) Signert for og vegne av

POLSKI: 1) Deklaracja zgodności UE; 2) Numer; 3) Producent; 4) Niniejsza deklaracja zgodności wydana zostaje na wyłączną odpowiedzialność producenta; 5) Przedmiot deklaracji; 6) Model/Typ; 7) Oznaczenie; 8) Opis; 9) Wymieniony powyżej przedmiot niniejszej deklaracji jest zgodny z odnosnymi wymaganiami unijnego prawodawstwa harmonizacyjnego; 10) Dyrektywa; 11) Standard; 12) Dodatkowe informacje; 13) Podpisano imieniem

PORTUGUÊS: 1) Declaração UE de conformidade; 2) Número; 3) Fabricante; 4) A presente declaração de conformidade é emitida sob a exclusiva responsabilidade do fabricante; 5) Objeto da declaração; 6) Modelo/Tipo; 7) A denominação; 8) Descrição; 9) O objeto da declaração acima descrito está em conformidade com a legislação de harmonização da União aplicável; 10) Diretiva; 11) Padrão; 12) Informações adicionais; 13) Assinado por e nome

ROMÂNĂ: 1) Declarația UE de conformitate; 2) Număr; 3) Producător; 4) Prezenta declarație de conformitate este emisă pe răspunderea exclusivă a producătorului; 5) Obiectul declarației; 6) Modelul/Tipul; 7) Desemnarea; 8) Descrierea; 9) Obiectul declarației descris mai sus este în conformitate cu legislația relevantă de armonizare a Uniunii; 10) Directivă; 11) Standard; 12) Informații adiționale; 13) Semnat pentru și în numele

SLOVENSKY: 1) EU Vyhlásenie o zhode; 2) Číslo; 3) Výrobca; 4) Toto vyhlásenie o zhode sa vydáva na výhradnú zodpovednosť výrobcu; 5) Predmet vyhlásenia; 6) Model/Typ; 7) Označenie; 8) Popis; 9) Uvedený predmet vyhlásenia je v zhode s príslušnými harmonizačnými právnymi predpismi Unie; 10) Smernice; 11) Standardné; 12) Doplňujúce informácie; 13) Podpísané za a mene na

SLOVENŠČINA: 1) Izjava EU o skladnosti; 2) Številko; 3) Proizvajalec; 4) Ta izjava o skladnosti je izdana na lastno odgovornost proizvajalca; 5) Predmet izjave; 6) Model/Tip; 7) Oznaka; 8) Opis; 9) Predmet navedene izjave je v skladu z ustrežno zakonodajo Unije o harmonizaciji; 10) Direktiva; 11) Standard; 12) Dodatne informacije; 13) Podpisano za in v imenu

ESPAÑOL: 1) Declaración UE de conformidad; 2) Número; 3) Fabricante; 4) La presente declaración de conformidad se expide bajo la exclusiva responsabilidad del fabricante; 5) Objeto de la declaración; 6) Tipo de modelo; 7) Designación; 8) Descripción; 9) El objeto de la declaración descrita anteriormente es conforme con la legislación de armonización pertinente de la Unión; 10) Directiva; 11) Estándar; 12) Información Adicional; 13) Firmado por y nombre

SVENSKA: 1) EU-Försäkran om överensstämmelse; 2) Nummer; 3) Tillverkare; 4) Denna försäkran om överensstämmelse utfärdas på tillverkarens eget ansvar; 5) Föremålet för försäkran; 6) Modell/Typ; 7) Beteckning; 8) Beskrivning; 9) Föremålet för försäkran ovan överensstämmer med den relevanta harmoniserade unionslagstiftningen; 10) Direktiv; 11) Standard; 12) Extra information; 13) Undertecknat för och på uppdrag av

Cables, plugs and jumpers

Schematical description of how to connect communication cables, termination plugs and interlock jumpers on all possible system configurations.

PBM350e/PBM500e Wiring Overview

2019-03-20

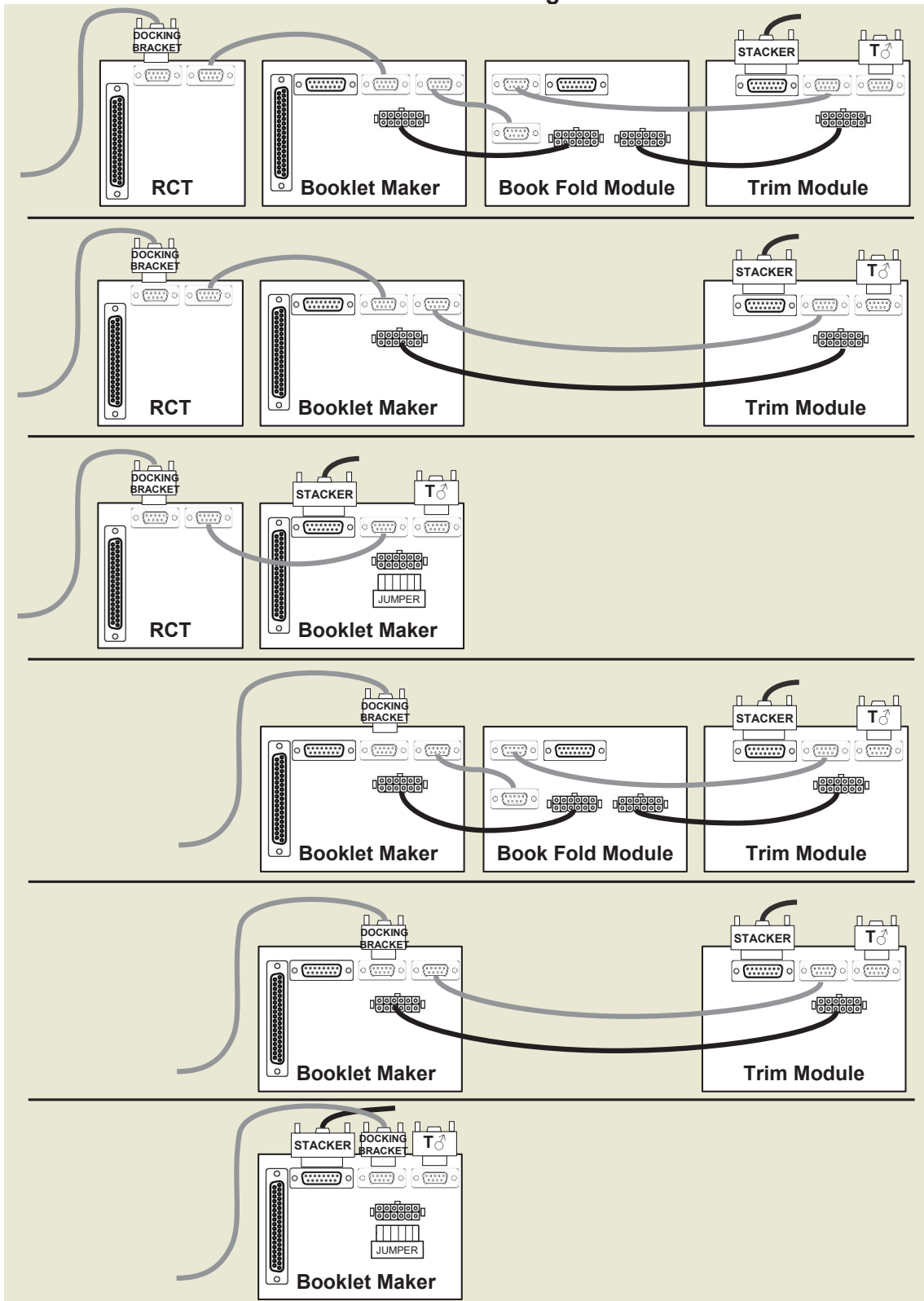

INDEX

A

Access to machine 85
Adjustment of Bleed Trimmer registration angle (parallel cut) 95
Adjust Trimmer registration 61
Air Separation 51
Alive logo 24
Auto Rotate 63
AUTO sheet size 47
Auto trimming 47

B

Basics 33
Basic settings 46
Begin On-line Production 58
Belt stacker 76
Belt Stacker 30, 36, 37, 38
Belt stacker fault codes 81
Best practice for the PBM350e/PBM500e system 97
Bleed Trimmer - Asymmetric Side Trim 56
Bleed Trimmer - Cover Adjust 56
BookFold 52
BookFold Module 26, 73, 87, 104
BookFold Module fault codes 80
BookFold offset 63
Booklet Maker 13, 70, 102
 Docking / Undocking 40
Booklet Maker fault codes 78
BST4000-1 Belt Stacker Module 30, 104, 105

C

Cables, plugs and jumpers 109
Change left/right staple cartridge(s) 34
Changing settings 46
Check left/right stapler 35
Cleaning feed belts 87
Cleaning feed rollers and paper separator pad 86
Cleaning of creaser tools (2x) 94
Cleaning the fixing rollers (3x) 90
Cleaning the paper path sensors (5x) 92
Cleaning the paper path transportation nip rollers (6x) 89
Cleaning the registration cross roller (4x) 91
Cleaning the rotator rollers (2x) 92
Clearing Misfeed(s) 67
Clearing misfeed(s) in the paper path 68
Control panel 16
Cover 50
Cover Feeder 25, 35, 72, 103
Cover Feeder fault codes 79
Crease 54
Crease Mode 54
Crease position 54
Custom booklet size 48
Customizing settings 49

D

Declaration of Conformity 106
Docking / Undocking 40
Do's And Don'ts 83
Double Sheet Detection 51

E

Emptying the trim bin 36

F

Fault codes 77
Fine-tuning booklet appearance 55
Finished Booklet Size 47
Fold delay 62
Fold position 50

G

General fault codes 82
General safety 4
Guided Start 43
Guide To Components 13

H

Handling jobs 65
How to read this manual 3

I

Input Sheet Size 46
Introduction 3

J

Jobs 65

L

Language 61
Limitations in the PBM350e/PBM500e system 98

M

Machine environment 84
Machine Specifications 101
Maintaining Your Machines 86
Making Booklets 43

O

Off-line mode 57
On-line mode 57
On-line/Off-line 57
Opening and handling stored Jobs 66
Options 19

P

Paper path light 60
PBM350e/PBM500e Booklet Maker 102
PBM BookFold Module 104
PBM RCTe Rotate Crease Trim Module (option) 101
PBM Trim Module 103
Plockmatic Cover Feeder 103
Power connection 84
Precision Fold 60
Pressure springs 88
Protection sheet 52
Purge Cover 52

R

RCT fault codes 77
RCT Module 68, 89
 Docking / Undocking 40
REMARKS 83
Rotate Crease Trim Module 19

S

Safety during operation 4
Safety Information 4
Saving a Job 65
Selecting BookFold pressure setting 53
Selecting standard paper sizes 46
Sensitive Staple 63
Service mode 61
Set registration (fine adjustment) 55
Set sheet count 62
Setting up Belt Stacker 36
Sheet feeder 62
Software version 60
Specification 101
Stacker full detection 59
Staple 49
System Set Size Guide 105

T

Tools 59
Trimmer 28, 74, 103
Trimmer fault codes 81
Trim Waste Conveyor 32, 105
 Detaching / Attaching 38
Troubleshooting 77
Turning On / Off the Main Power 33

U

Units 59
User interface 16

W

What You Can Do With This Machine 11
Where to put Your Machine 84

